



US011590391B2

(12) **United States Patent**
Tarkington et al.

(10) **Patent No.:** **US 11,590,391 B2**
(45) **Date of Patent:** **Feb. 28, 2023**

(54) **PORTABLE DEVICES FOR EXERCISING MUSCLES IN THE ANKLE, FOOT, AND/OR LEG, AND RELATED METHODS**

(71) Applicant: **TS MEDICAL LLC**, McLean, VA (US)

(72) Inventors: **Mary Anne Tarkington**, McLean, VA (US); **David G. Matsuura**, Solana Beach, CA (US); **Jacob A. Moebius**, Encinitas, CA (US); **Louis John Stack**, Calgary (CA)

(73) Assignee: **TS MEDICAL LLC**, McLean, VA (US)

(*) Notice: Subject to any disclaimer, the term of this patent is extended or adjusted under 35 U.S.C. 154(b) by 0 days.

(21) Appl. No.: **17/562,682**

(22) Filed: **Dec. 27, 2021**

(65) **Prior Publication Data**

US 2022/0118311 A1 Apr. 21, 2022

Related U.S. Application Data

(62) Division of application No. 16/570,817, filed on Sep. 13, 2019, now Pat. No. 11,207,559.
(Continued)

(51) **Int. Cl.**
A63B 23/08 (2006.01)
A63B 22/16 (2006.01)
(Continued)

(52) **U.S. Cl.**
CPC **A63B 23/08** (2013.01); **A63B 21/0085** (2013.01); **A63B 21/022** (2015.10);
(Continued)

(58) **Field of Classification Search**
CPC ... **A63B 23/08**; **A63B 21/0085**; **A63B 21/022**;
A63B 21/0407; **A63B 21/0442**;
(Continued)

(56) **References Cited**

U.S. PATENT DOCUMENTS

735,319 A * 8/1903 Urwick A63B 21/04
482/146

1,509,793 A 9/1924 Thompson et al.
(Continued)

FOREIGN PATENT DOCUMENTS

CN 111184601 5/2020
DE 548527 C 10/1932
(Continued)

OTHER PUBLICATIONS

Office Action in U.S. Appl. No. 13/482,844, dated Aug. 31, 2012.
(Continued)

Primary Examiner — Garrett K Atkinson

(74) *Attorney, Agent, or Firm* — Jones Robb, PLLC

(57) **ABSTRACT**

A method for exercising muscles in an ankle, foot, and/or leg of a user includes positioning a foot of a user onto a first body of an exercise device. The first body is spaced away from a second body of the device and pivotably connected to the second body of the device at a pivot axis. The pivot axis is adjacent to a central portion of the first body. The method includes rotating the first body about the pivot axis, with the foot, against a first resistive force. Rotating the first body includes subjecting the foot to a first motion. The method includes positioning the foot onto the second body. The method includes rotating the second body about the pivot axis, with the foot, against a second resistive force. Rotating the second body includes subjecting the foot to a second motion, the second motion being different than the first motion.

23 Claims, 59 Drawing Sheets

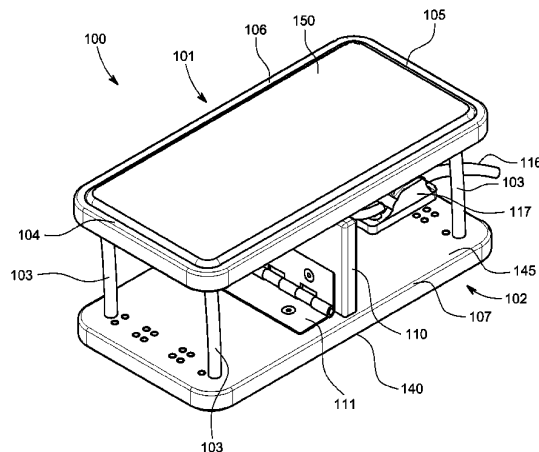

Related U.S. Application Data

<p>(60) Provisional application No. 62/731,647, filed on Sep. 14, 2018.</p> <p>(51) Int. Cl. <i>A63B 21/04</i> (2006.01) <i>A63B 21/02</i> (2006.01) <i>A63B 21/008</i> (2006.01) <i>A63B 21/00</i> (2006.01) <i>A63B 21/055</i> (2006.01) <i>A63B 21/05</i> (2006.01) <i>A63B 21/22</i> (2006.01) <i>A63B 22/00</i> (2006.01) <i>A63B 23/00</i> (2006.01) <i>A63B 23/10</i> (2006.01)</p> <p>(52) U.S. Cl. CPC <i>A63B 21/0407</i> (2013.01); <i>A63B 21/0442</i> (2013.01); <i>A63B 21/05</i> (2013.01); <i>A63B 21/0557</i> (2013.01); <i>A63B 21/151</i> (2013.01); <i>A63B 21/22</i> (2013.01); <i>A63B 21/4015</i> (2015.10); <i>A63B 21/4047</i> (2015.10); <i>A63B 22/16</i> (2013.01); <i>A63B 23/085</i> (2013.01); <i>A63B 23/10</i> (2013.01); <i>A63B 2022/0038</i> (2013.01); <i>A63B 2022/0097</i> (2013.01); <i>A63B 2023/006</i> (2013.01); <i>A63B 2210/50</i> (2013.01); <i>A63B 2210/52</i> (2013.01); <i>A63B 2210/54</i> (2013.01); <i>A63B 2210/56</i> (2013.01); <i>A63B 2210/58</i> (2013.01)</p> <p>(58) Field of Classification Search CPC ... <i>A63B 21/05</i>; <i>A63B 21/0557</i>; <i>A63B 21/151</i>; <i>A63B 21/22</i>; <i>A63B 21/4015</i>; <i>A63B 21/4047</i>; <i>A63B 22/16</i>; <i>A63B 23/085</i>; <i>A63B 23/10</i>; <i>A63B 2022/0038</i>; <i>A63B 2022/0097</i>; <i>A63B 2023/006</i>; <i>A63B 2210/50</i>; <i>A63B 2210/52</i>; <i>A63B 2210/54</i>; <i>A63B 2210/56</i>; <i>A63B 2210/58</i>; <i>A63B 21/023</i>; <i>A63B 21/0421</i>; <i>A63B 21/0552</i>; <i>A63B 21/4034</i>; <i>A63B 23/03508</i>; <i>A63B 2209/14</i>; <i>A63B 2225/093</i>; <i>A63B 71/0036</i>; <i>A63B 2208/0228</i>; <i>A63B 2208/0252</i>; <i>A63B 2209/08</i>; <i>A63B 2209/10</i>; <i>A63B 2225/62</i></p> <p>See application file for complete search history.</p> <p>(56) References Cited U.S. PATENT DOCUMENTS</p>	<p>4,574,785 A 3/1986 Yamamoto 4,605,220 A 8/1986 Troxel 4,637,379 A 1/1987 Saringer 4,669,722 A 6/1987 Rangaswamy 4,694,684 A 9/1987 Campbell, III 4,718,665 A 1/1988 Airy et al. 4,733,859 A 3/1988 Kock et al. 4,739,986 A 4/1988 Kucharik et al. 4,779,866 A 10/1988 Marshall et al. D299,063 S 12/1988 Young et al. 4,795,148 A 1/1989 Rangaswamy 4,801,138 A 1/1989 Airy et al. 4,816,920 A 3/1989 Paulsen 4,822,039 A 4/1989 Gonzales et al. 4,836,531 A 6/1989 Niks 4,979,737 A 12/1990 Kock 5,014,690 A 5/1991 Hepburn et al. 5,038,758 A 8/1991 Iams et al. 5,041,717 A 8/1991 Shay, III et al. 5,048,783 A 9/1991 Grimes 5,052,379 A 10/1991 Airy et al. 5,074,000 A 12/1991 Soltani et al. 5,108,092 A 4/1992 Hurst 5,129,872 A 7/1992 Dalton et al. 5,209,716 A 5/1993 Frydman et al. 5,215,508 A 6/1993 Bastow 5,230,681 A 7/1993 Hannum et al. 5,263,911 A 11/1993 Frydman et al. 5,306,222 A 4/1994 Wilkinson 5,337,737 A 8/1994 Rubin et al. 5,352,185 A 10/1994 Blauth et al. 5,368,536 A 11/1994 Stodgell 5,454,769 A 10/1995 Chen 5,465,428 A 11/1995 Earl 5,489,251 A 2/1996 Robles, Jr. 5,520,627 A 5/1996 Malewicz 5,570,472 A 11/1996 Dicker 5,582,567 A * 12/1996 Chang A63B 22/16 482/146</p> <p>5,606,745 A 3/1997 Gray 5,611,770 A 3/1997 Tesch 5,645,516 A * 7/1997 Foster A63B 23/085 482/121</p> <p>5,722,919 A 3/1998 Timmer 5,727,254 A 3/1998 Dicker 5,733,249 A 3/1998 Katzin et al. 5,743,837 A 4/1998 Dias et al. 5,755,651 A * 5/1998 Homyonfer A63B 22/16 482/130</p> <p>5,788,618 A 8/1998 Joutras 5,839,122 A 11/1998 Dicker et al. 5,842,959 A 12/1998 Wilkinson 5,851,166 A * 12/1998 Bernardson A63B 23/03533 482/79</p> <p>5,857,947 A 1/1999 Dicker et al. 5,867,826 A 2/1999 Wilkinson 5,873,847 A 2/1999 Bennett et al. 5,879,276 A 3/1999 Miller 5,897,464 A * 4/1999 Mcleod A63B 23/08 601/27</p> <p>6,010,468 A 1/2000 Grove et al. 6,024,714 A 2/2000 Katzin 6,047,406 A 4/2000 Dicker et al. 6,063,013 A * 5/2000 Vathappallil A63B 21/151 482/79</p> <p>6,206,807 B1 3/2001 Cowans et al. 6,217,488 B1 * 4/2001 Bernardson A63B 23/03533 482/79</p> <p>6,244,992 B1 * 6/2001 James A61H 1/0237 482/79</p> <p>6,254,034 B1 7/2001 Carpenter 6,261,253 B1 7/2001 Katzin 6,277,057 B1 8/2001 Hayden 6,283,897 B1 * 9/2001 Patton A63B 21/4015 482/79</p> <p>6,390,957 B1 5/2002 Knight 6,436,058 B1 8/2002 Krahner et al.</p>
---	---

(56)

References Cited

U.S. PATENT DOCUMENTS

6,569,213 B1 *	5/2003	Busch	A63B 21/026	482/80	D726,844 S *	4/2015	Mathew	D21/685
6,572,514 B1 *	6/2003	Calafato	A63B 22/16	482/79	D734,411 S	7/2015	Powers et al.	
6,589,141 B1	7/2003	Flaggs			9,072,645 B2	7/2015	Gamman et al.	
6,656,097 B2	12/2003	Karecki			9,095,177 B2	8/2015	Ota et al.	
6,705,975 B2 *	3/2004	Kuo	A63B 23/0429	482/52	9,114,277 B2	8/2015	Goeckel	
6,780,142 B1 *	8/2004	Takizawa	A63B 22/203	482/8	9,192,806 B2	11/2015	Mial	
6,796,928 B1 *	9/2004	Christopher	A63B 22/0056	482/52	9,230,057 B2	1/2016	Stark et al.	
6,808,476 B2	10/2004	Zagone			9,247,784 B2 *	2/2016	Stewart	A63B 21/023
6,821,235 B1 *	11/2004	Johnson	A63B 21/4015	482/79	9,295,303 B2	3/2016	Baker et al.	
6,837,831 B2	1/2005	Lee			9,302,137 B1	4/2016	Yelvington	
7,008,357 B2	3/2006	Winkler			9,327,156 B2	5/2016	von Hoffmann et al.	
7,074,204 B2	7/2006	Fujii et al.			9,377,079 B2	6/2016	DeHarde	
7,160,231 B2	1/2007	Kazemi			9,433,814 B2	9/2016	von Hoffmann et al.	
D538,814 S	3/2007	Cranford et al.			9,474,673 B2	10/2016	Horst et al.	
D553,379 S	10/2007	Genelli			D776,211 S *	1/2017	Gebhard	D21/685
7,294,114 B1	11/2007	Clement et al.			9,539,135 B2	1/2017	Romo et al.	
7,316,637 B2	1/2008	German et al.			9,566,469 B1	2/2017	Rector	
7,322,904 B2 *	1/2008	Takizawa	A63B 22/203	482/8	9,592,416 B2	3/2017	Thorpe	
7,364,534 B2 *	4/2008	Zoller	A63B 23/08	482/79	9,603,768 B1	3/2017	Widmer et al.	
7,398,571 B2	7/2008	Souke et al.			9,656,117 B2	5/2017	von Hoffmann et al.	
7,452,340 B2	11/2008	Cook et al.			9,737,753 B2 *	8/2017	Chuang	A63B 22/0012
7,481,739 B2 *	1/2009	Takizawa	A63B 23/03541	482/8	9,770,617 B2	9/2017	von Hoffmann et al.	
7,481,751 B1	1/2009	Arnold			9,814,273 B2	11/2017	Nordstrom et al.	
7,485,074 B2 *	2/2009	Chen	A61H 1/0266	482/79	9,849,328 B1 *	12/2017	Fulks	A63B 23/10
7,500,324 B1 *	3/2009	Power	A43B 13/145	482/79	9,872,789 B2	1/2018	Sorrenti et al.	
7,537,555 B2	5/2009	Soletski			9,873,017 B2 *	1/2018	Barel	A63B 21/0557
7,641,591 B2 *	1/2010	Takizawa	A63B 21/4015	482/8	9,895,569 B2	2/2018	Yao	
D613,409 S	4/2010	Genelli			9,914,009 B2	3/2018	Tarkington et al.	
7,771,327 B1 *	8/2010	Reams	A63B 21/4034	482/80	9,930,928 B2	4/2018	Whiteman et al.	
7,775,941 B2	8/2010	Nguyen et al.			9,931,540 B1 *	4/2018	Lazar	A63B 26/003
7,883,451 B2 *	2/2011	Hand	A63B 23/085	482/110	10,004,937 B2	6/2018	Matsuura et al.	
7,892,154 B1	2/2011	Alexa			10,076,460 B2	9/2018	Harry et al.	
7,918,813 B2	4/2011	Drake et al.			10,118,063 B2	11/2018	DeYoung	
8,015,638 B2	9/2011	Shimada et al.			10,124,205 B2	11/2018	Matsuura et al.	
8,029,420 B1 *	10/2011	Thati	A63B 22/0056	482/79	D836,206 S	12/2018	Pettinato et al.	
8,092,350 B2 *	1/2012	Chinag	A63B 21/00181	482/52	10,143,878 B2	12/2018	Gottfried	
8,123,663 B2	2/2012	Fey et al.			10,179,078 B2	1/2019	Bhugra et al.	
8,231,508 B1	7/2012	Rousseau			10,434,357 B2 *	10/2019	McCarthy	A63B 21/0552
8,246,522 B2 *	8/2012	Piaget	A63B 22/0056	482/80	10,653,913 B2 *	5/2020	Yao	A63B 23/0405
8,267,839 B1	9/2012	Bartolotta			10,702,740 B2	7/2020	Tarkington et al.	
8,312,566 B2	11/2012	Weir et al.			10,946,247 B1 *	3/2021	Burton	A63B 71/0054
8,353,854 B2	1/2013	Horst et al.			2002/0165069 A1 *	11/2002	Ravikumar	A63B 23/10
8,360,940 B2 *	1/2013	Kole	A63B 21/0552	482/79	2002/0193210 A1 *	12/2002	Turner	A63B 21/4047
8,366,591 B2	2/2013	Patoglu			2003/0060339 A1 *	3/2003	Ravikumar	A63B 22/0056
8,403,817 B2	3/2013	Ferguson et al.			2004/0087419 A1	5/2004	Ware et al.	482/80
8,430,796 B1 *	4/2013	Tarkington	A63B 21/00189	482/52	2005/0251067 A1	11/2005	Terry	482/80
8,460,163 B2	6/2013	Gibbons			2005/0261113 A1	11/2005	Wilkinson	482/80
8,480,546 B2	7/2013	Spencer			2006/0103219 A1	5/2006	Sardana	
8,678,979 B2	3/2014	Stark et al.			2006/0122040 A1	6/2006	Nguyen et al.	
D712,044 S *	8/2014	Mathew	D24/188		2006/0276736 A1	12/2006	Devreese	
8,827,873 B2 *	9/2014	Arnstein	A63B 23/085	602/5	2007/0135279 A1	6/2007	Purdy et al.	
8,840,530 B2	9/2014	Baker et al.			2008/0083055 A1	4/2008	Onda	
8,986,177 B2	3/2015	von Hoffmann et al.			2009/0192024 A1	7/2009	Wu	
					2010/0145233 A1	6/2010	Zhang et al.	
					2010/0222180 A1	9/2010	Takizawa	
					2010/0323859 A1	12/2010	von Hoffmann et al.	
					2011/0046524 A1	2/2011	Mihara et al.	
					2011/0077560 A1	3/2011	Jacofsky et al.	
					2011/0111927 A1 *	5/2011	Kim	A63B 22/0056
					2011/0112447 A1	5/2011	Hsiao-Wecksler et al.	482/52
					2011/0172578 A1	7/2011	Chiu et al.	
					2011/0314590 A1	12/2011	Perron et al.	
					2013/0041302 A1	2/2013	Williams	
					2013/0079686 A1	3/2013	Sessions	
					2013/0184617 A1	7/2013	Inaba	
					2013/0237386 A1	9/2013	Tsai	
					2014/0179497 A1	6/2014	von Hoffmann et al.	
					2014/0196190 A1	7/2014	Brown	
					2014/0302971 A1	10/2014	Vining	
					2014/0325732 A1	11/2014	Anderson	
					2014/0336009 A1	11/2014	Piaget et al.	
					2015/0165260 A1	6/2015	Tarkington et al.	
					2015/0223526 A1	8/2015	Nolan	
					2015/0314157 A1	11/2015	Lampert et al.	
					2016/0095367 A1	4/2016	Curran	

(56)

References Cited

U.S. PATENT DOCUMENTS

2016/0183606 A1 6/2016 Shriver
 2016/0256732 A1 9/2016 Kasner et al.
 2016/0279012 A1* 9/2016 Hurtado A61H 35/006
 2016/0361222 A1 12/2016 Publicover et al.
 2017/0072250 A1 3/2017 Heiskanen
 2017/0246501 A1 8/2017 Palmer
 2017/0246502 A1 8/2017 Palmer
 2017/0246503 A1 8/2017 Palmer
 2017/0252601 A1 9/2017 McKenzie
 2017/0274249 A1 9/2017 Moebius et al.
 2017/0361151 A1 12/2017 Mottern
 2018/0093121 A1 4/2018 Matsuura et al.
 2018/0093122 A1 4/2018 Stevenson et al.
 2018/0098707 A1 4/2018 Salamon et al.
 2018/0104536 A1* 4/2018 Stewart A63B 21/023
 2018/0111016 A1 4/2018 Brockway, Jr. et al.
 2018/0207477 A1* 7/2018 Barel A63B 23/08
 2019/0001176 A1 1/2019 Gustafson
 2019/0029336 A1 1/2019 Collins et al.
 2019/0160322 A1* 5/2019 McCarthy A63B 21/4034
 2020/0086170 A1 3/2020 Tarkington et al.
 2020/0086172 A1 3/2020 Tarkington et al.
 2020/0406093 A1 8/2020 Tarkington et al.
 2021/0038943 A1 2/2021 Tarkington et al.
 2021/0361999 A1 11/2021 Tarkington et al.

FOREIGN PATENT DOCUMENTS

DE 20221403 U1 11/2005
 EP 2854958 A1 4/2015
 FR 3024838 A3 2/2016
 GB 2372458 A 8/2002
 GB 2404877 A 2/2005
 GB 2460039 A 11/2009
 JP 2009254700 A 11/2009
 WO 2009128565 A1 10/2009
 WO 2013035905 A1 3/2013
 WO 2013101920 7/2013
 WO 2013181063 A1 12/2013
 WO 2015196190 12/2015
 WO 2019164633 A2 8/2019
 WO 2019194885 A1 10/2019

OTHER PUBLICATIONS

International Search Report and Written Opinion in PCT Appln No. PCT/US2013/042441, dated Sep. 6, 2013.
 Office Action in CA Appln No. 2,874,237, dated Dec. 10, 2015.
 Communication in EP Appln No. 13727007.0, dated Mar. 20, 2017.
 International Search Report in PCT Appln No. PCT/US2019/015031, dated Aug. 30, 2019.

International Search Report in PCT Appln No. PCT/US2019/015030, dated Jul. 1, 2019.
 Related U.S. Appl. No. 16/570,817 entitled Portable Devices for Exercising Muscles in the Ankle Foot and/or Leg and Related Methods filed Sep. 13, 2019.
 Design U.S. Appl. No. 29/746,283, filed Aug. 22, 2020, 62 Pages.
 U.S. Appl. No. 17/045,257, filed Oct. 5, 2020, 93 pages.
 Design U.S. Appl. No. 29/724,141, filed Feb. 12, 2020, 37 Pages.
 U.S. Pat. No. 0,735,319 to A.W. Urwick, dated Aug. 4, 1903.
 Notice of Allowance dated Mar. 3, 2020 in connection with U.S. Appl. No. 16/570,742, 38 pp.
 Notice of Allowance dated Aug. 19, 2021 in connection with U.S. Appl. No. 16/570,817, 12 pp.
 Office Action for U.S. Appl. No. 16/570,817, dated May 13, 2021.
 Office Action dated Oct. 12, 2021 in related U.S. Appl. No. 29/724,141, 12 pages.
 FF Finer form store, announced 2018 [online], [site visited Dec. 6, 2021]. Available on internet, URL:https://www.amazon.com/Finer-Form-Multi-Functional-Bench-Workout/dp/B07GYXF65S/ref=sr_l_196_sspa?dchild=1&keywords=adjustable+ankle+and-foot+board&qid=1633368733&sr=8-196-spons&psc=1 (Year: 2018).
 Barwing, announced 2020[online], [site visited Dec. 6, 2021]. Available on internet, URL:https://www.amazon.com/dp/B07WDHNKKB/ref=sspa_dk_detail_1?psc=1&pd_rd_i=B07WDHNKKB&pd_rd_w=ovaff&pf_rd_p=9fd3ea7c-b77c-42ac-b43b-c872d3f37c38&pd_rd_wg=K4R8E&pf_rd_r=QGNJ4V8P6PRKQYFAPHRE&pd_rd_r=c9b8a389 (Year: 2020).
 Office Action dated Dec. 21, 2021 in related U.S. Appl. No. 17/045,257, 16 pages.
 U.S. Appl. No. 16/975,577, filed Aug. 25, 2020, 83 Pages.
 U.S. Appl. No. 16/918,671, filed Jul. 1, 2020, 111 Pages.
 Office Action dated Oct. 13, 2021 in related U.S. Appl. No. 16/918,671, 11 pages.
 Examination report dated Dec. 7, 2021 for CA app No. 197544.
 Office Action dated Jun. 20, 2022 in U.S. Appl. No. 16/975,577, 15 pages.
 Notice of Refusal in Korean Application No. 30-2020-00306898, dated Sep. 3, 2021 and Aug. 30, 2021.
 Final Office Action dated Feb. 1, 2022 in U.S. Appl. No. 29/724,141.
 Notice of Allowance dated Feb. 4, 2022 in U.S. Appl. No. 16/918,671.
 Notice of Allowance dated Dec. 3, 2021 in Mexican Patent Application No. MX/f/2020/001920.
 Examination report dated Feb. 15, 2022 in Canadian Patent Application No. 209921.
 Notice of Allowance dated Apr. 19, 2022 in U.S. Appl. No. 29/724,141.
 Notice of Allowance dated Apr. 26, 2022 in Korean Application No. 30-2020-0036898.
 Final Office Action dated Jul. 6, 2022 in U.S. Appl. No. 17/045,257, 15 pp.
 Notice of Allowance dated Aug. 26, 2022 in US Application No. MX/a/2021/003732.

* cited by examiner

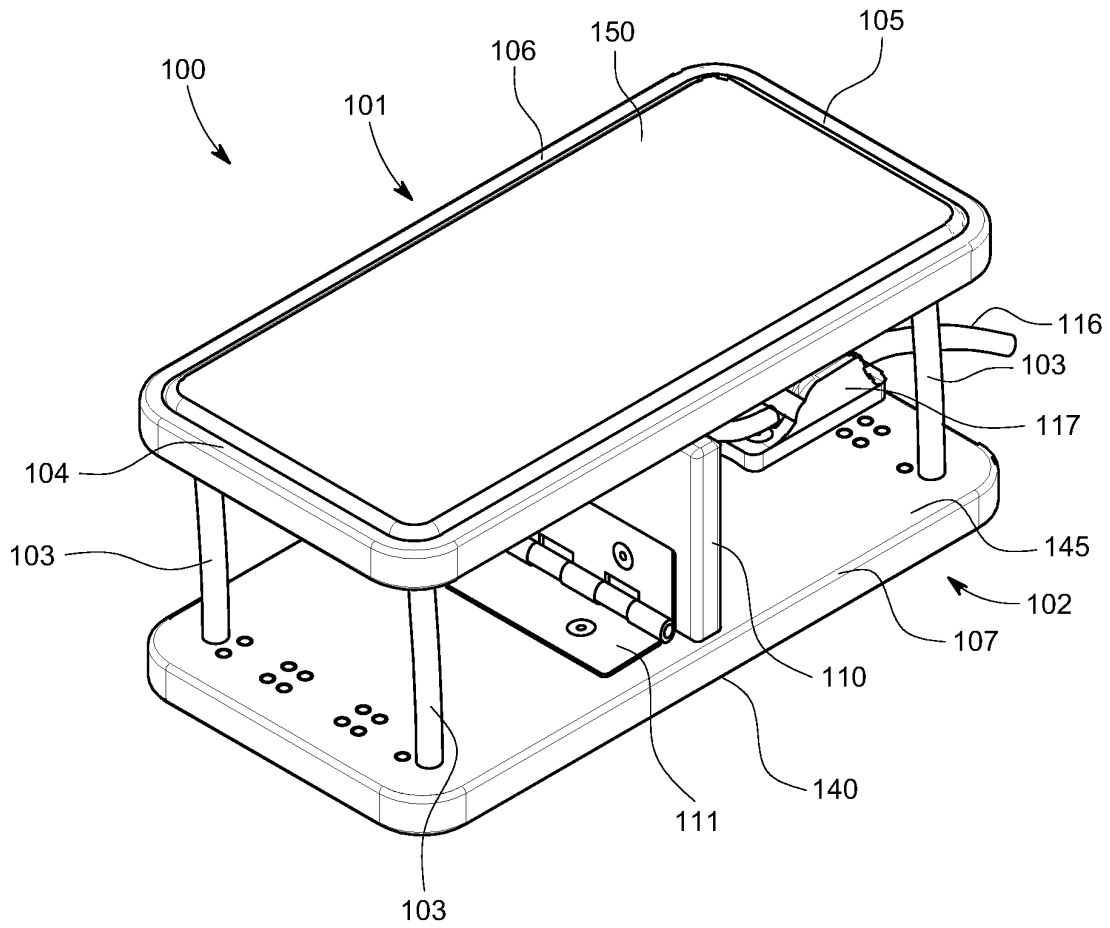

FIG. 1

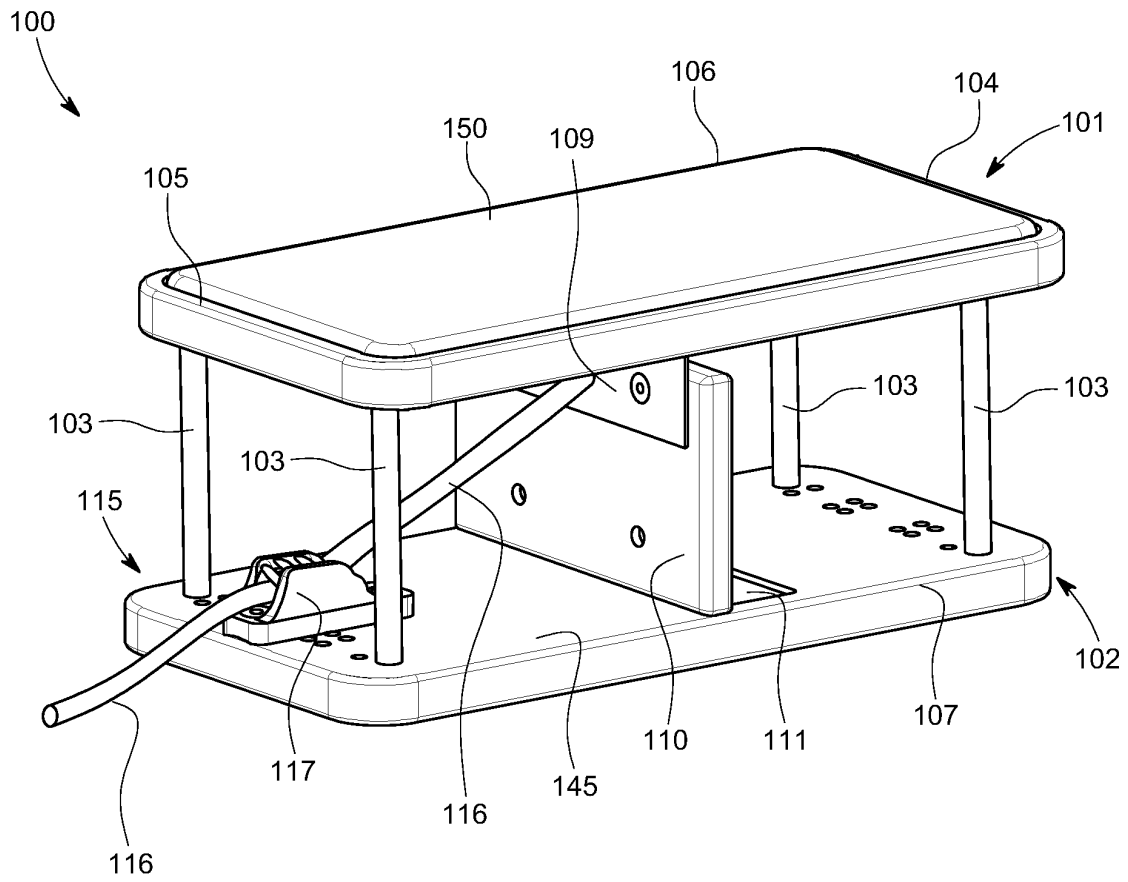

FIG. 2

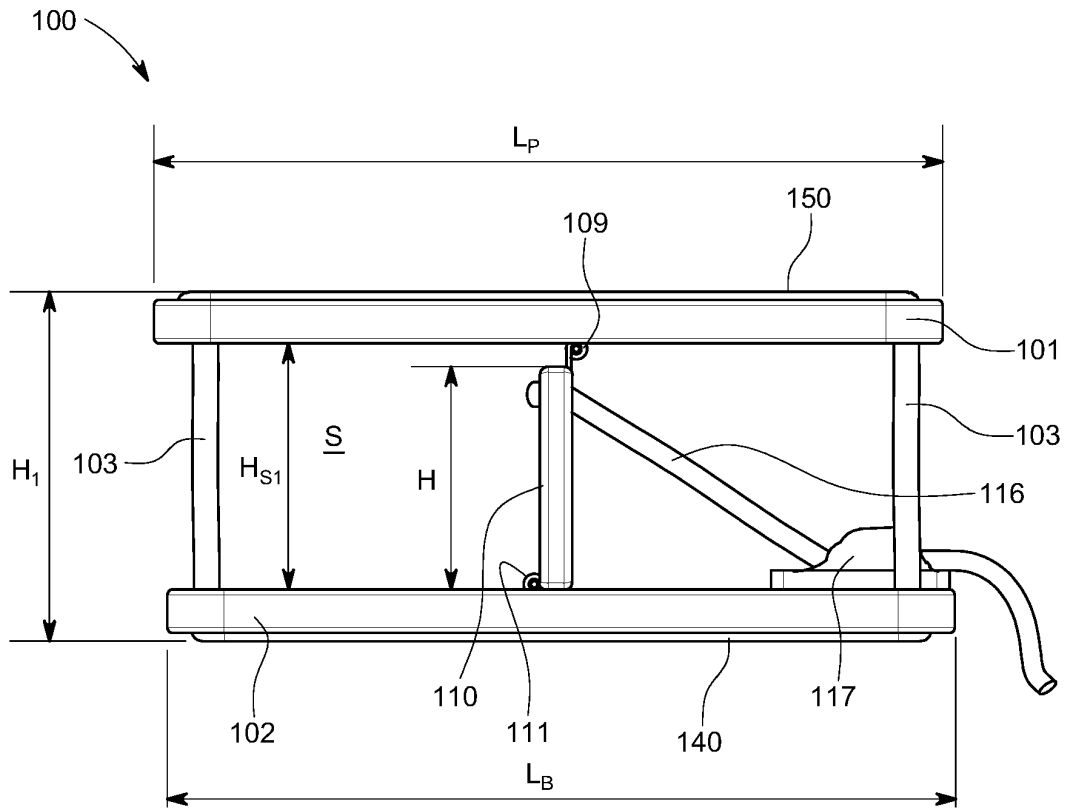

FIG. 3

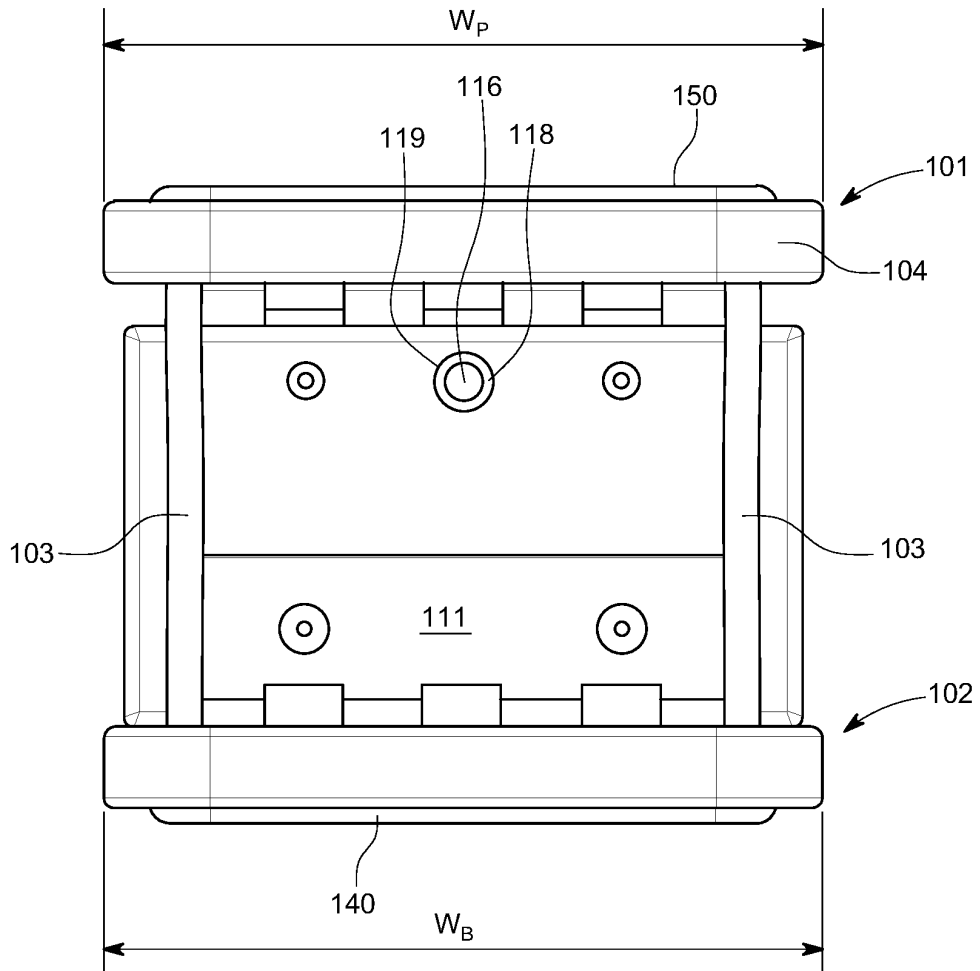

FIG. 4

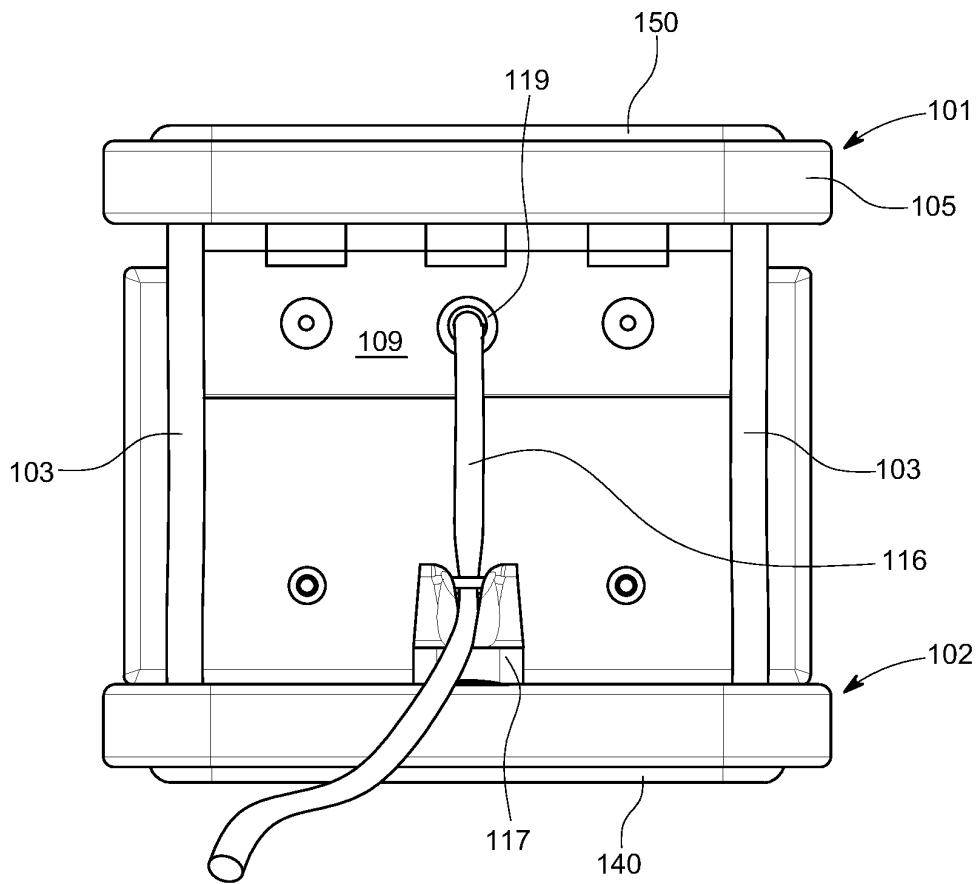

FIG. 5

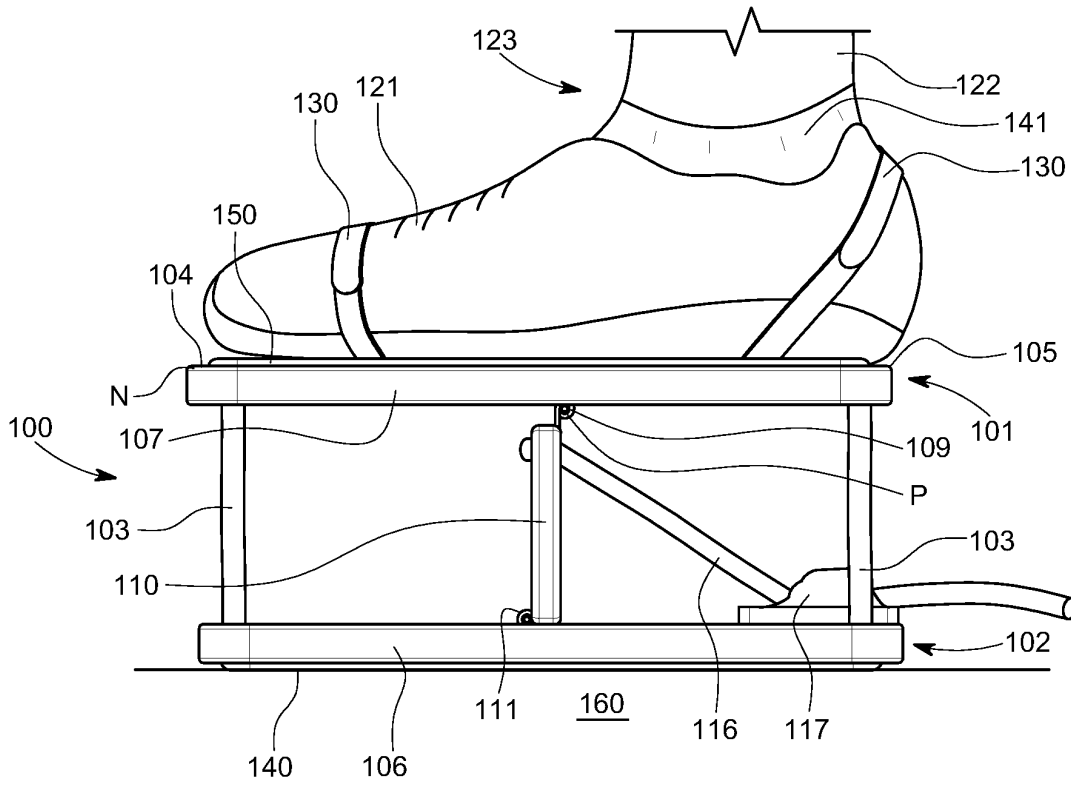

FIG. 6

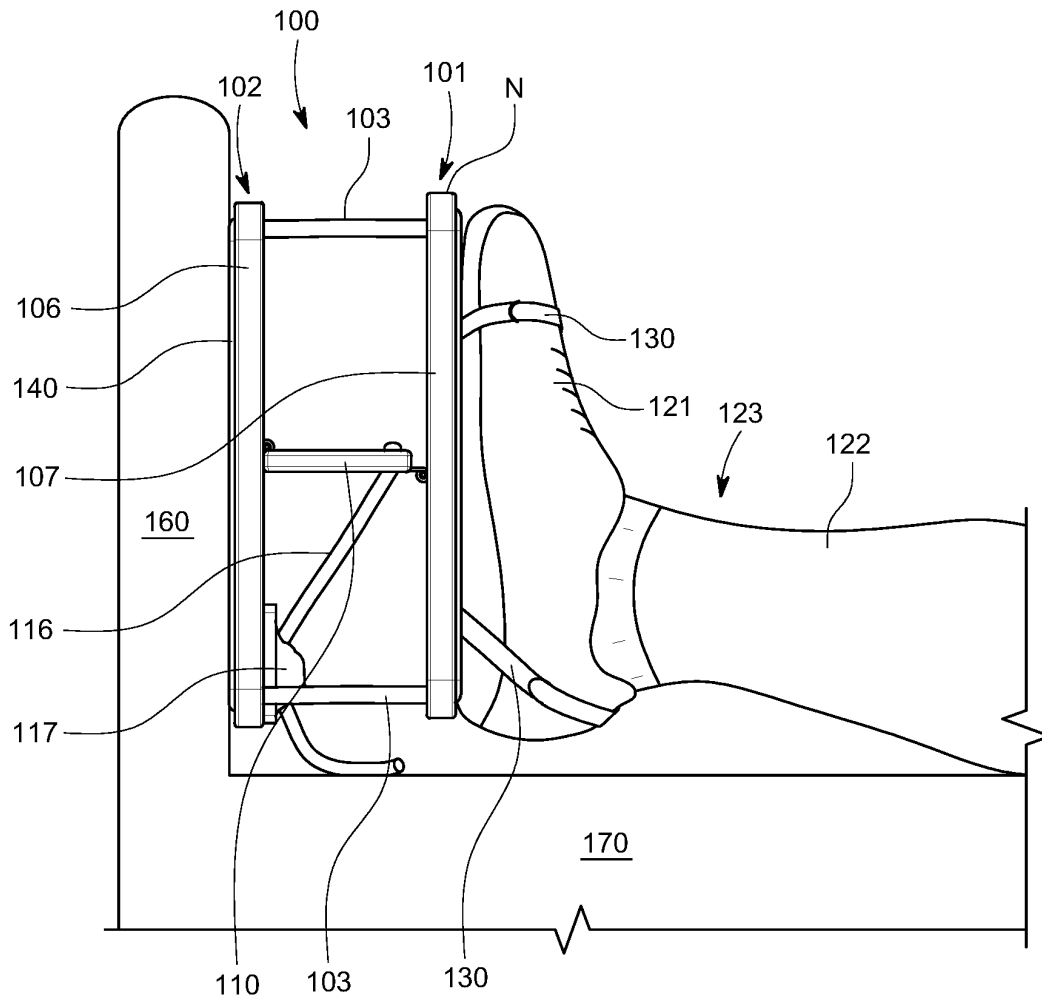

FIG. 7

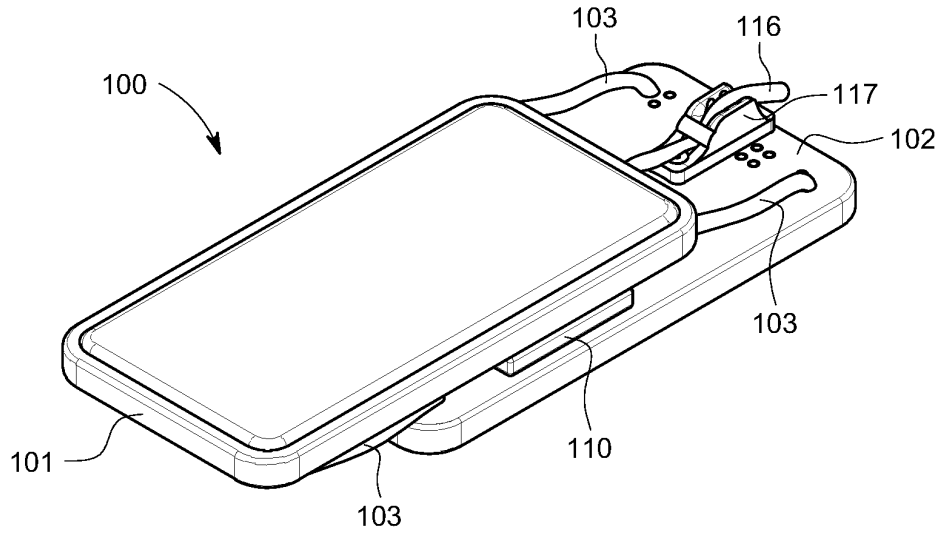

FIG. 8

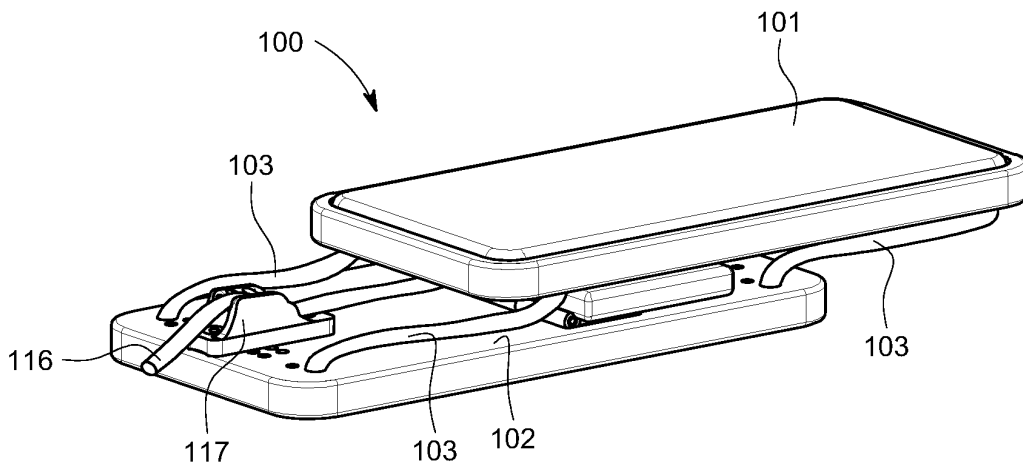

FIG. 9

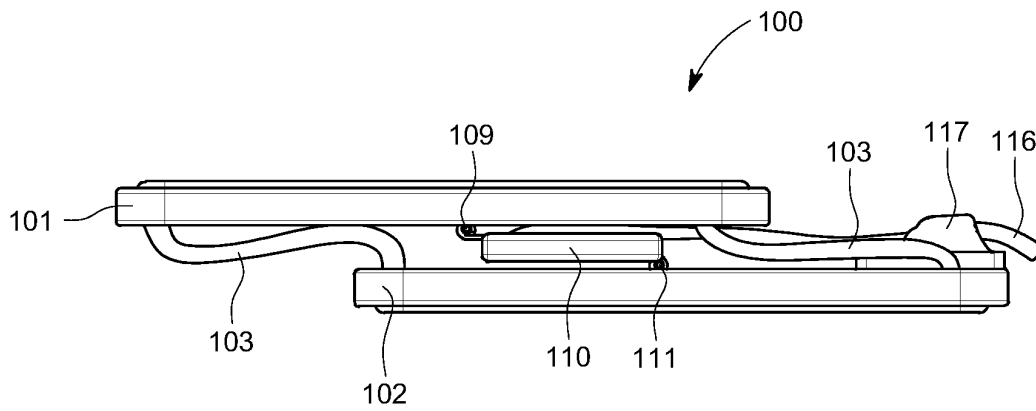

FIG. 10

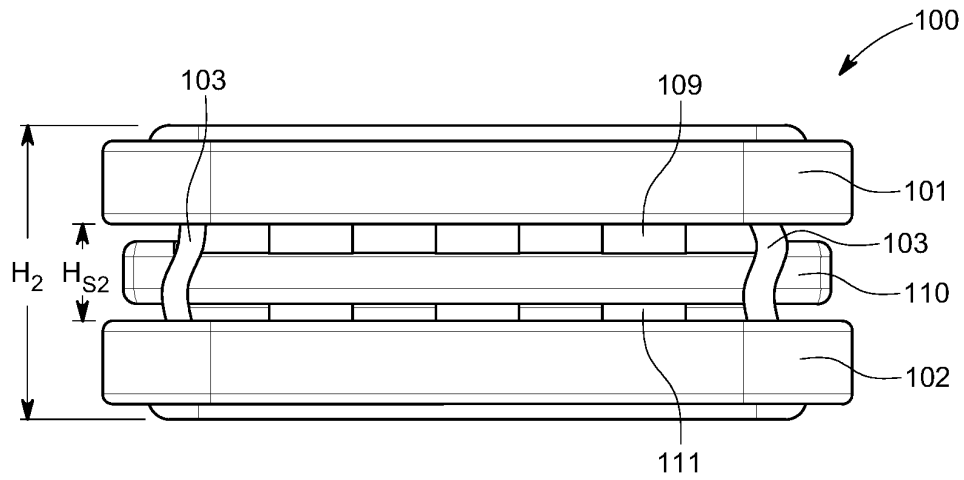

FIG. 11

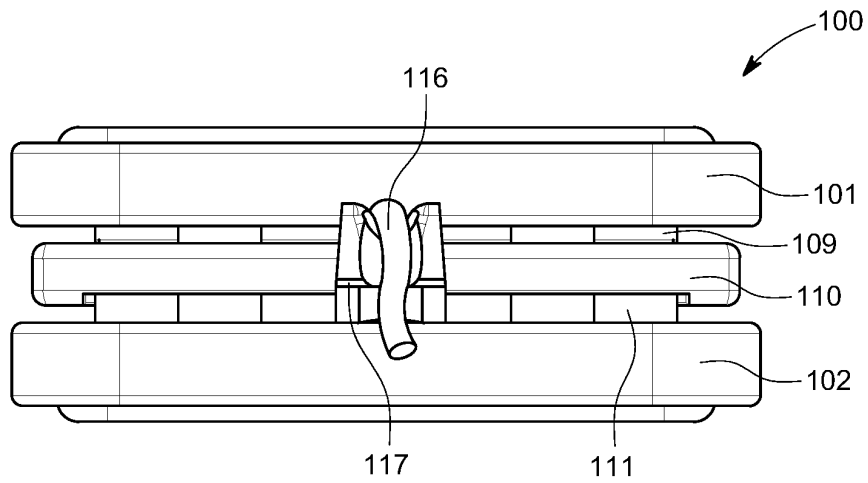

FIG. 12

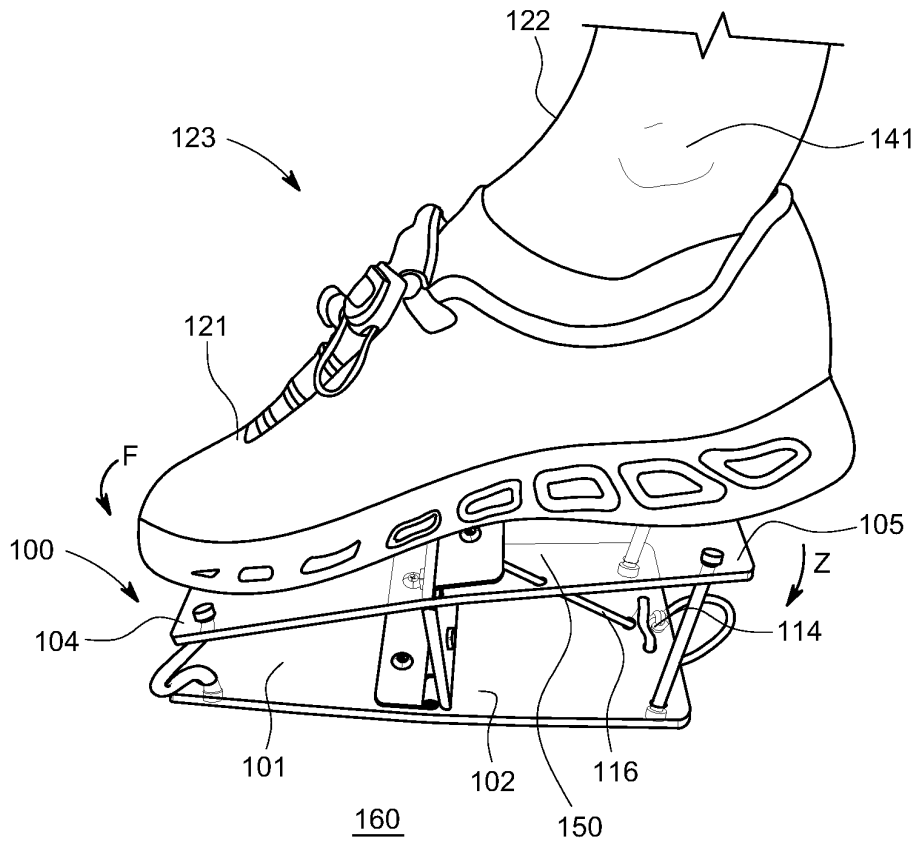

FIG. 13A

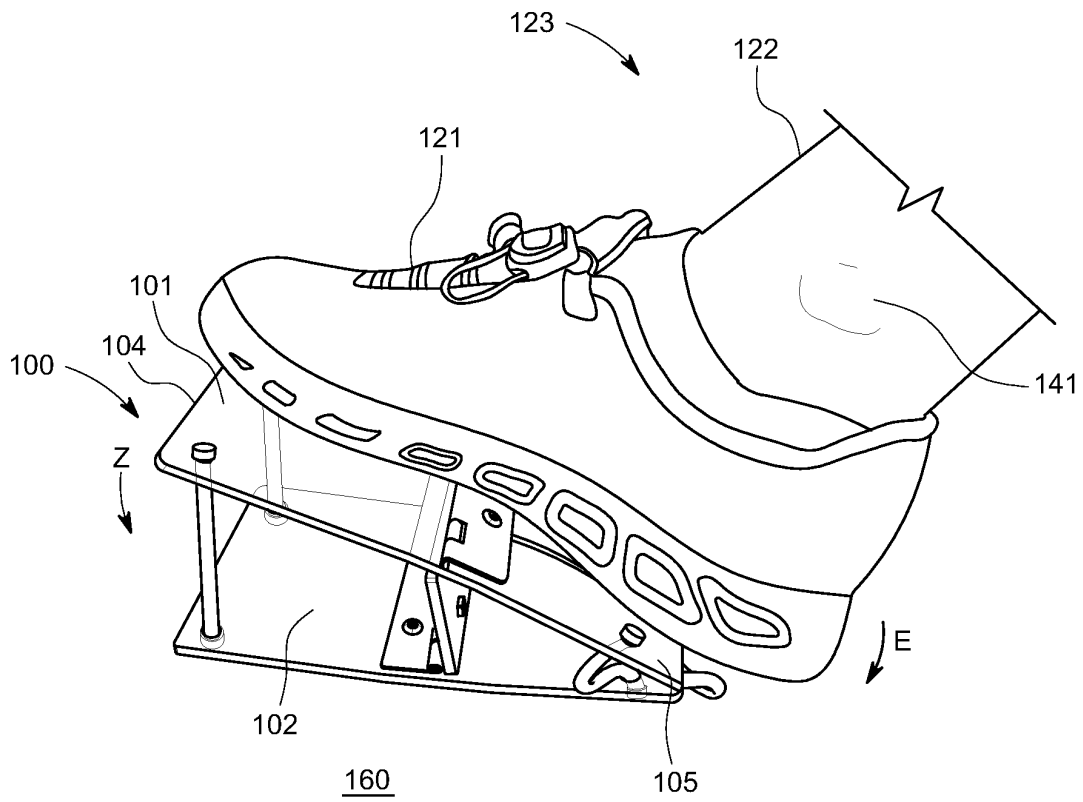

FIG. 13B

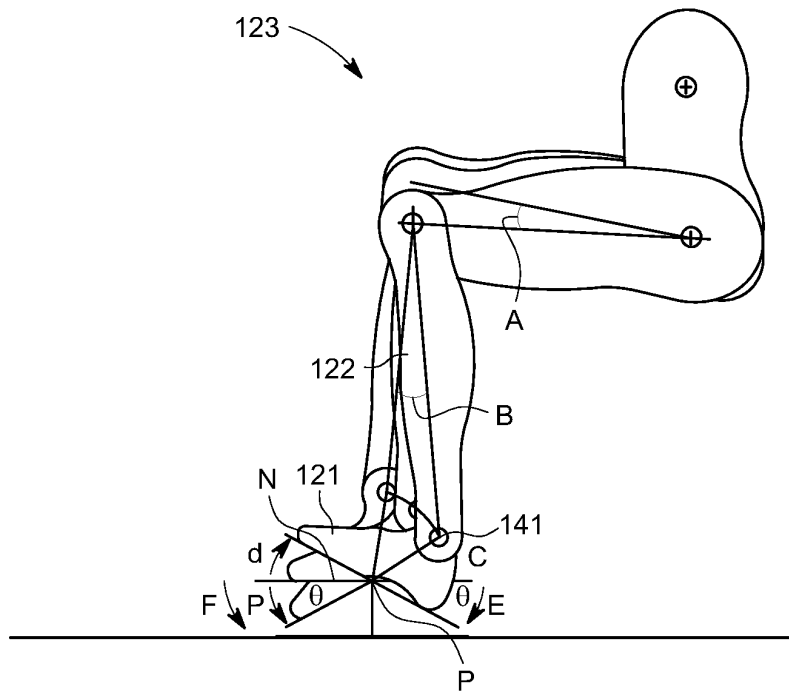

FIG. 14

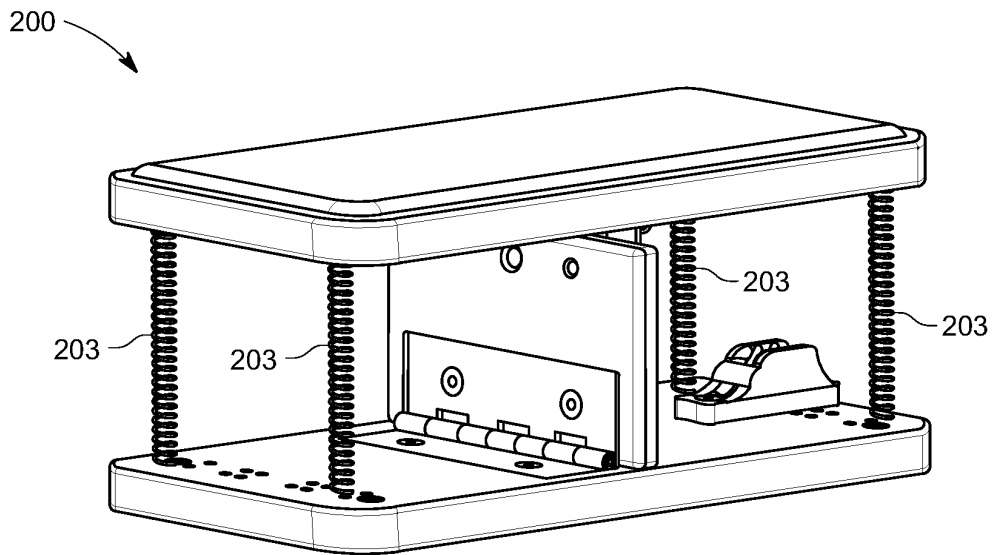

FIG. 15

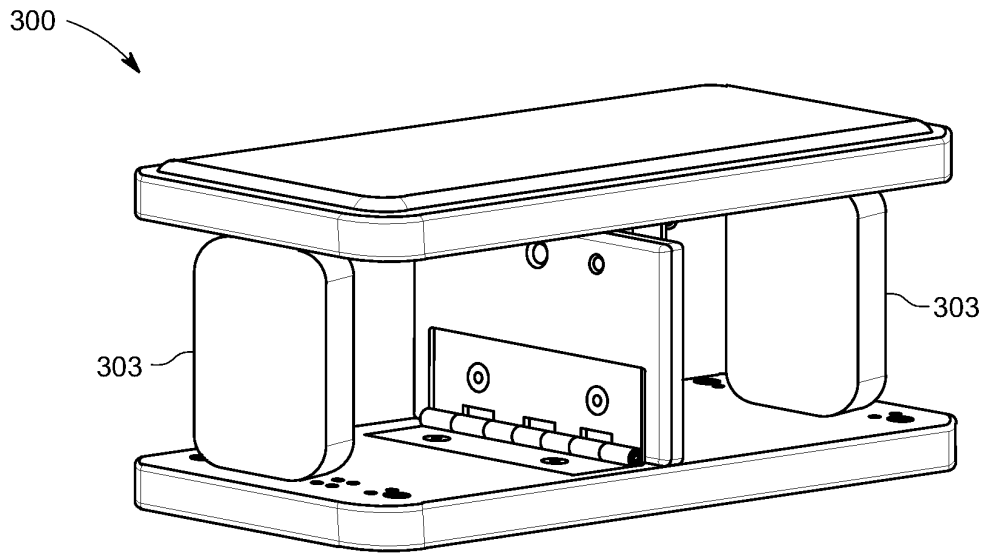

FIG. 16

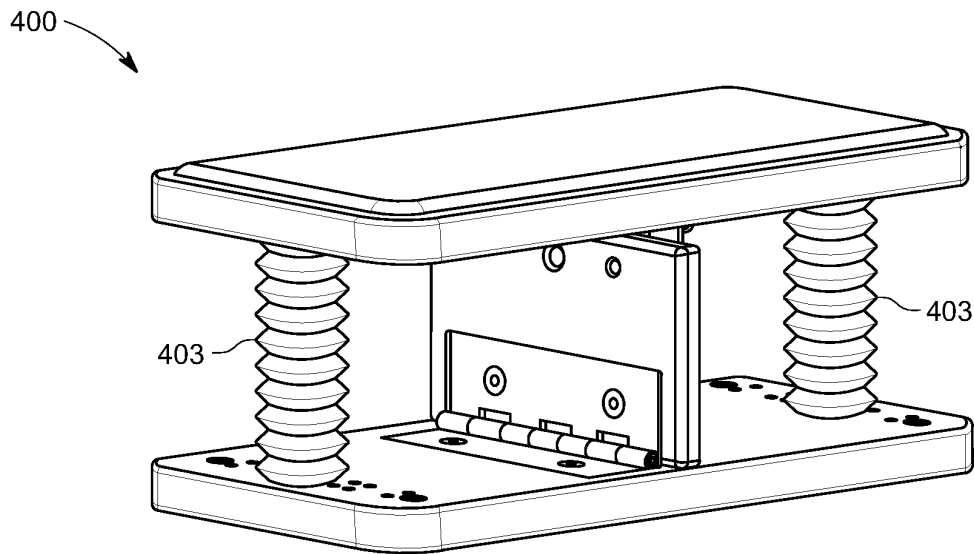

FIG. 17

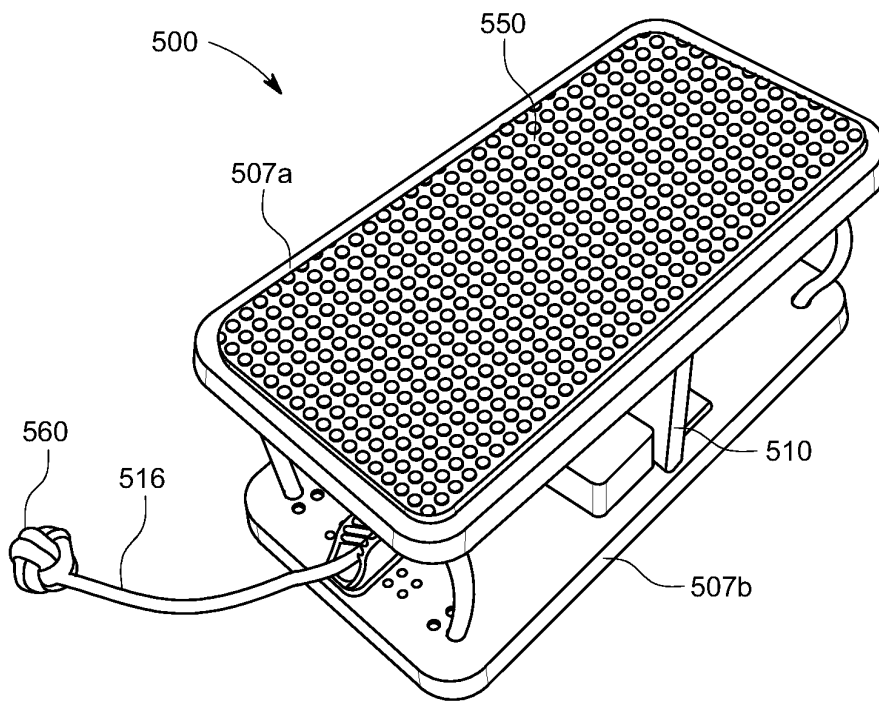

FIG. 18

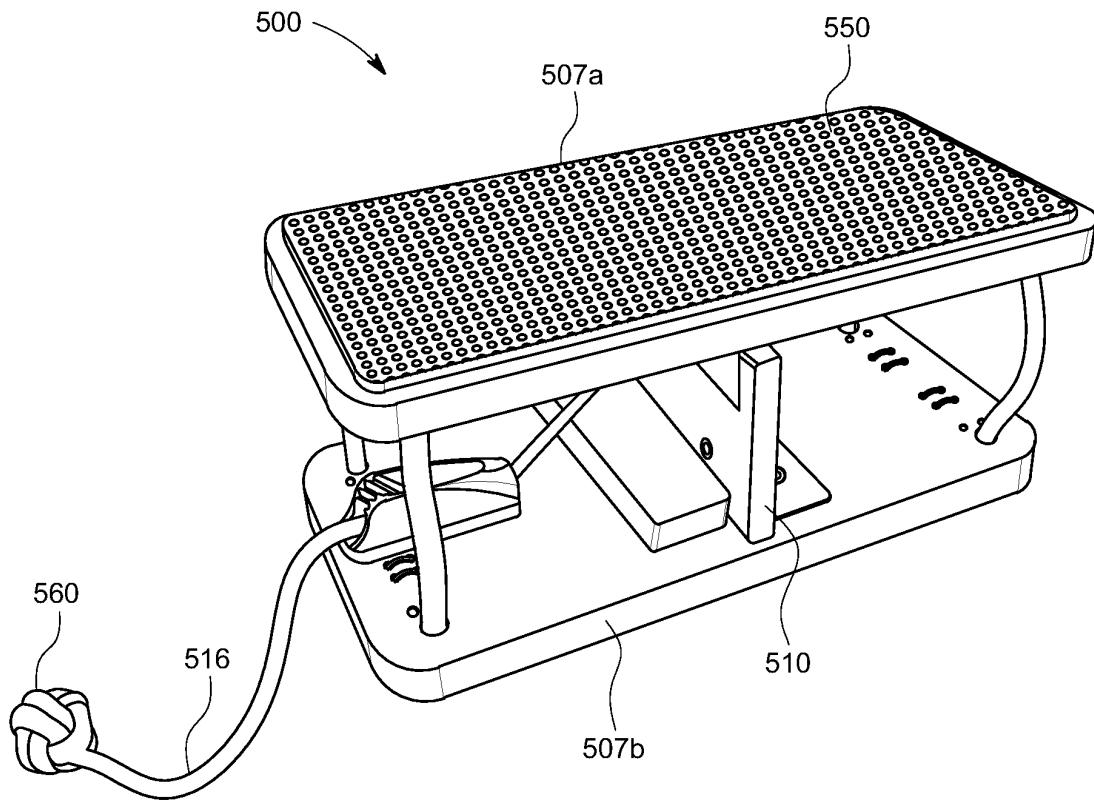

FIG. 19

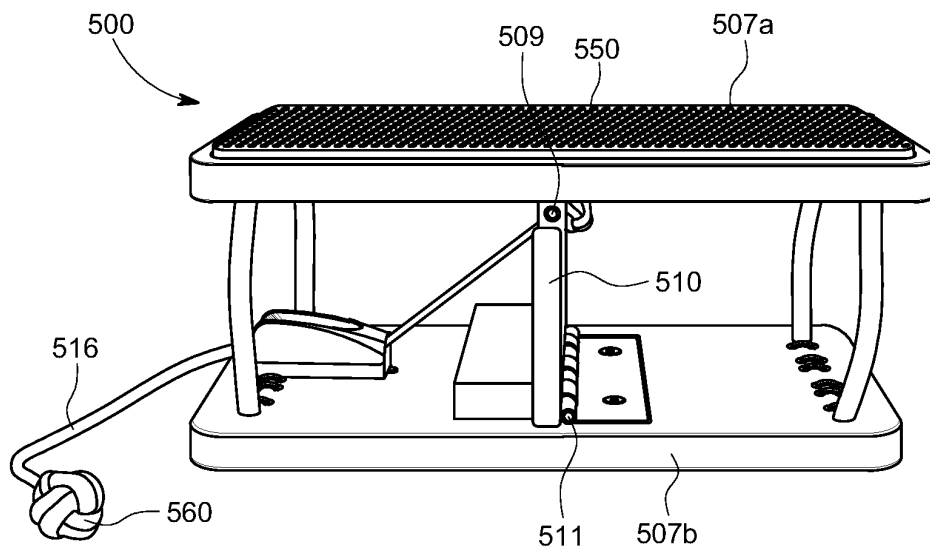

FIG. 20

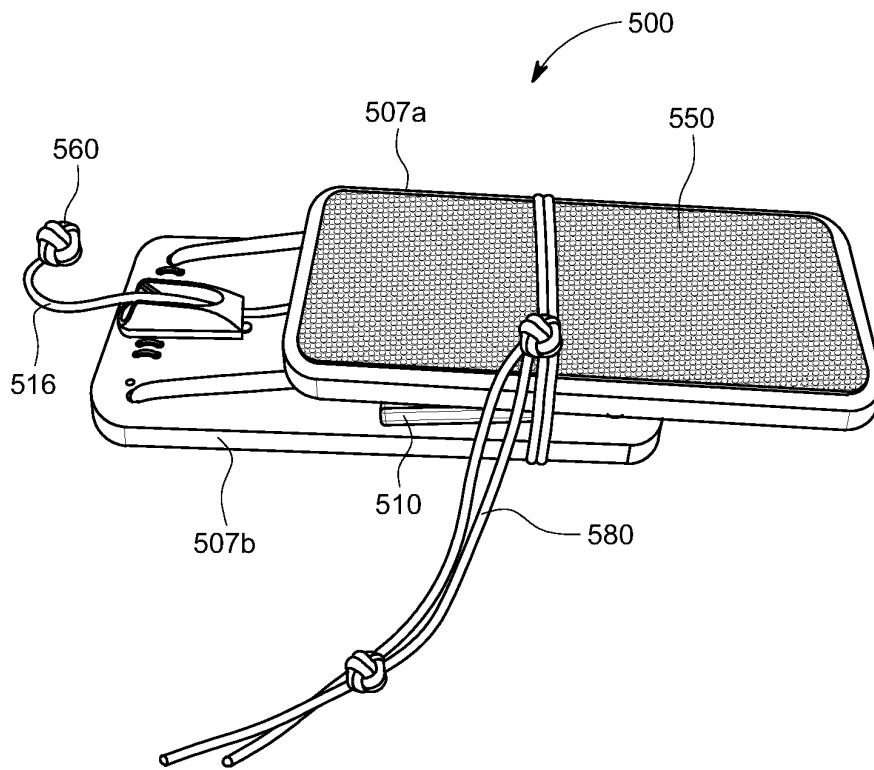

FIG. 21

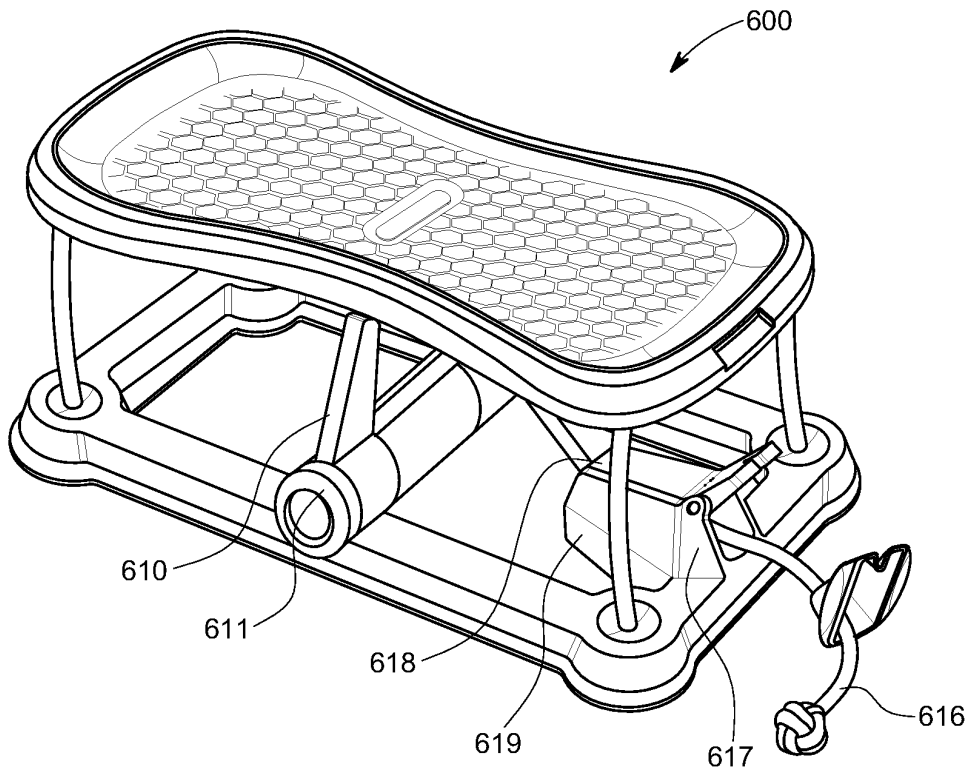

FIG. 22

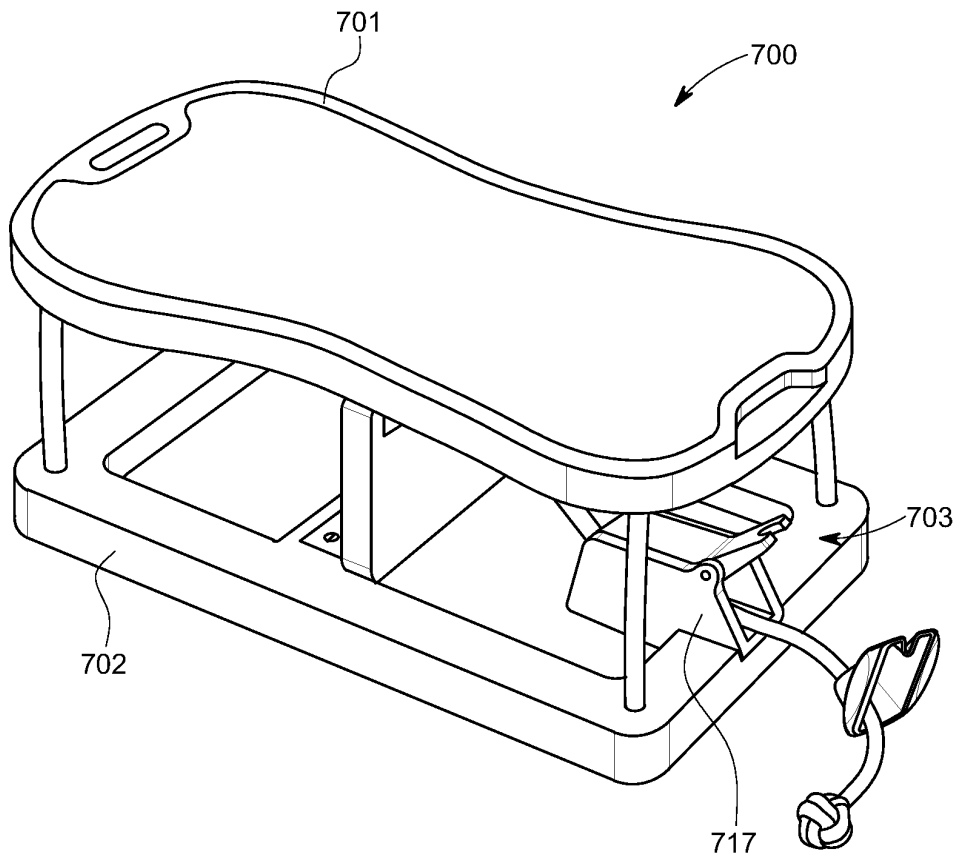

FIG. 23

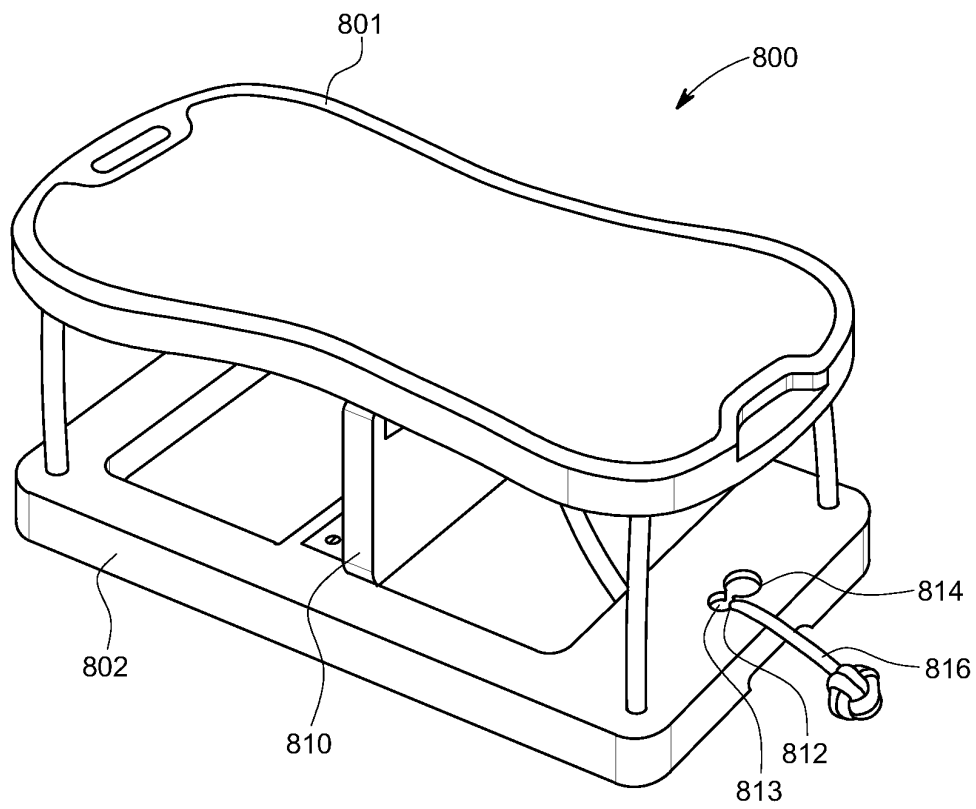

FIG. 24

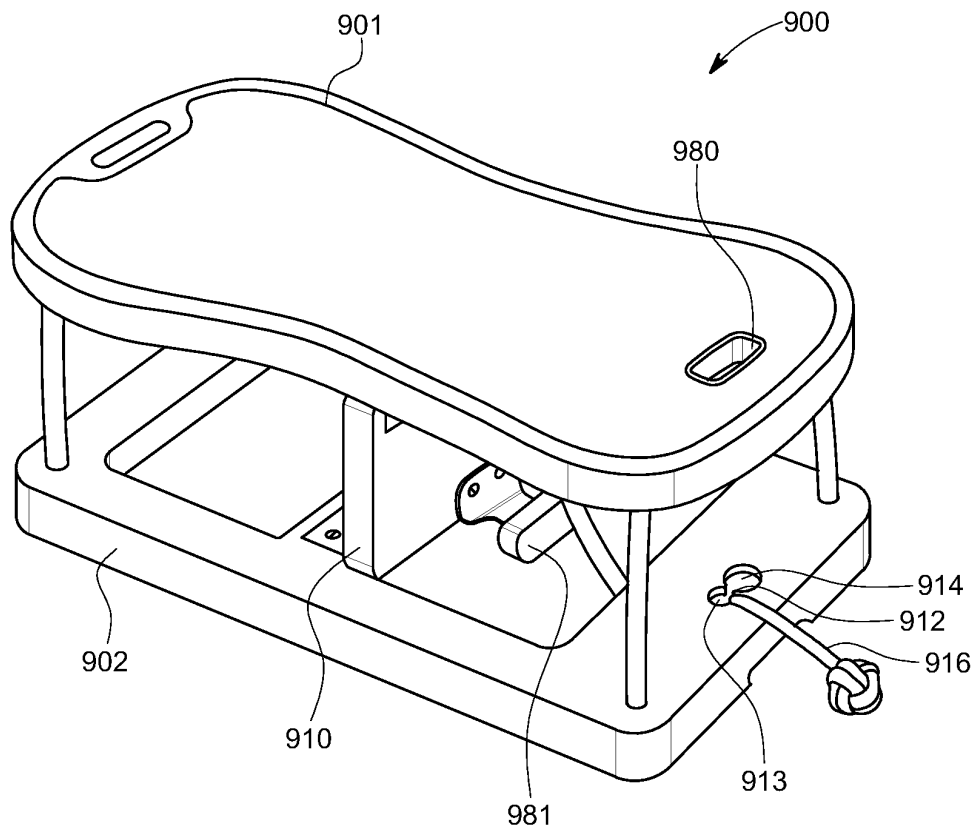

FIG. 25

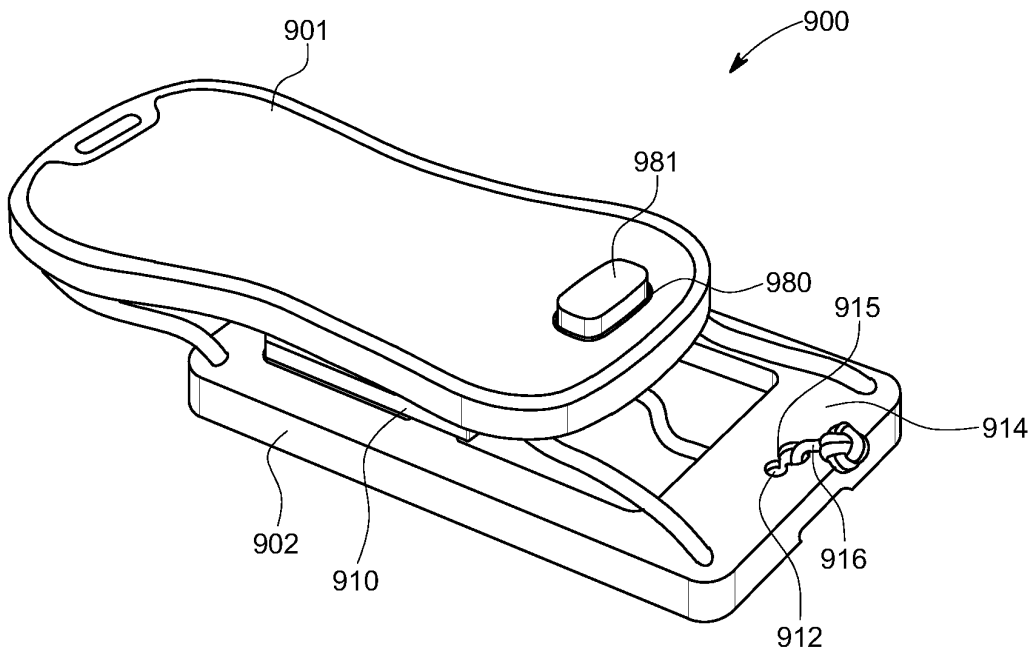

FIG. 26

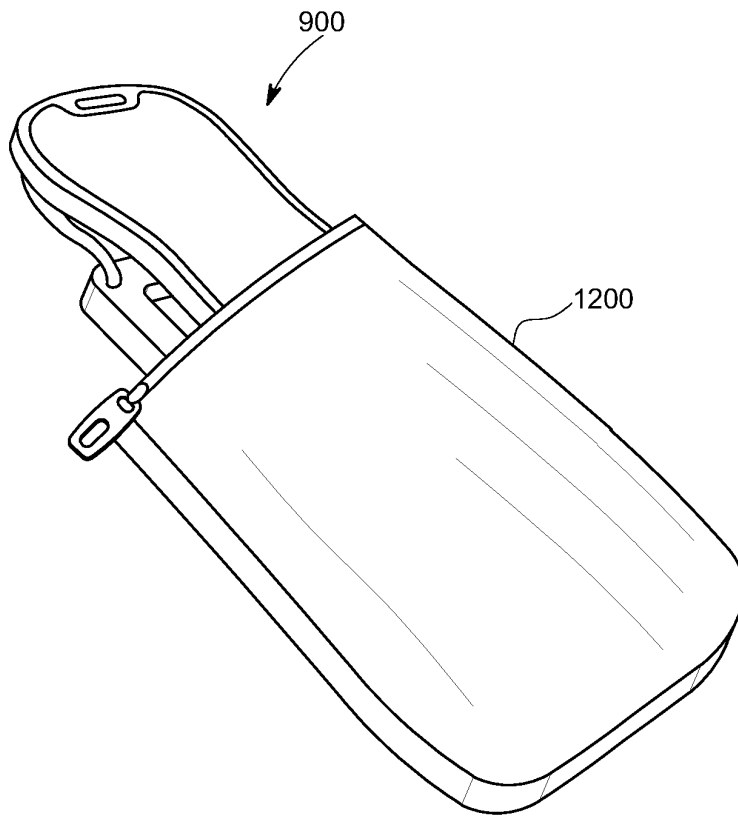

FIG. 27

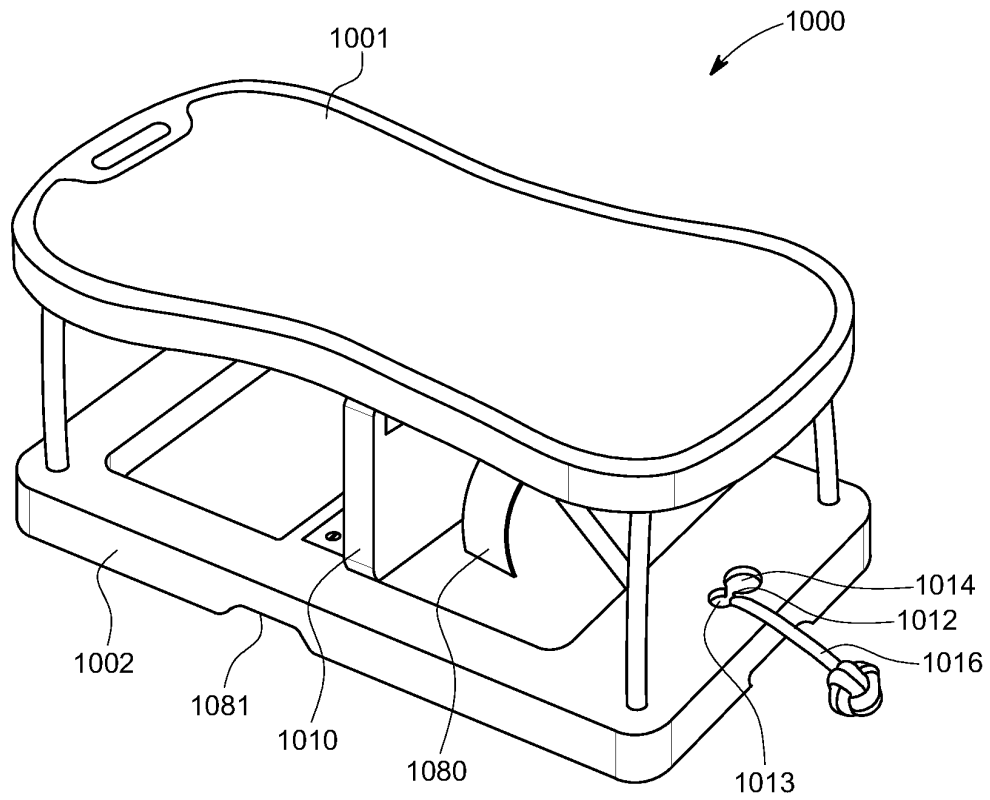

FIG. 28

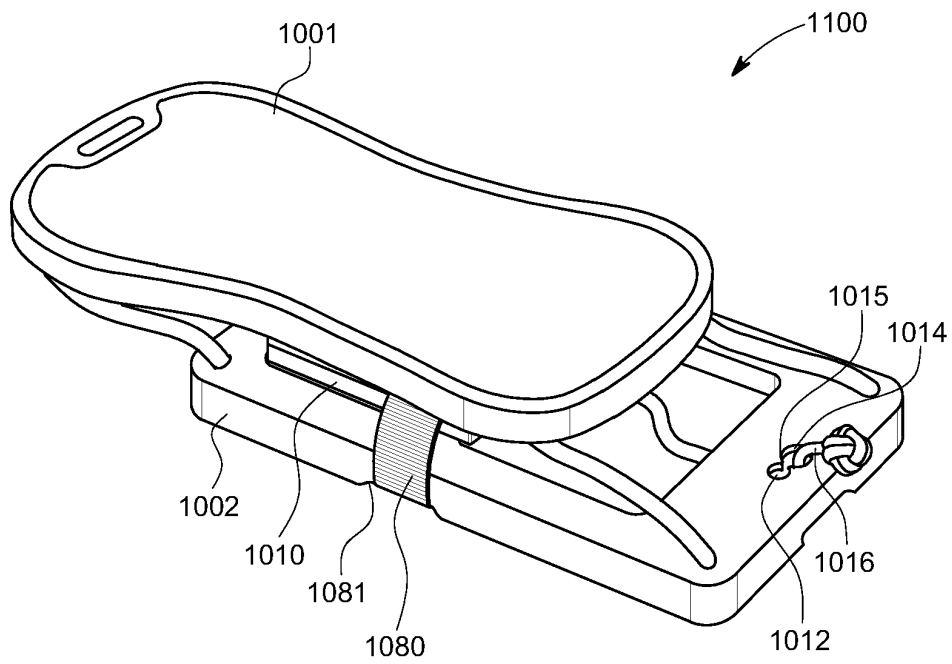

FIG. 29

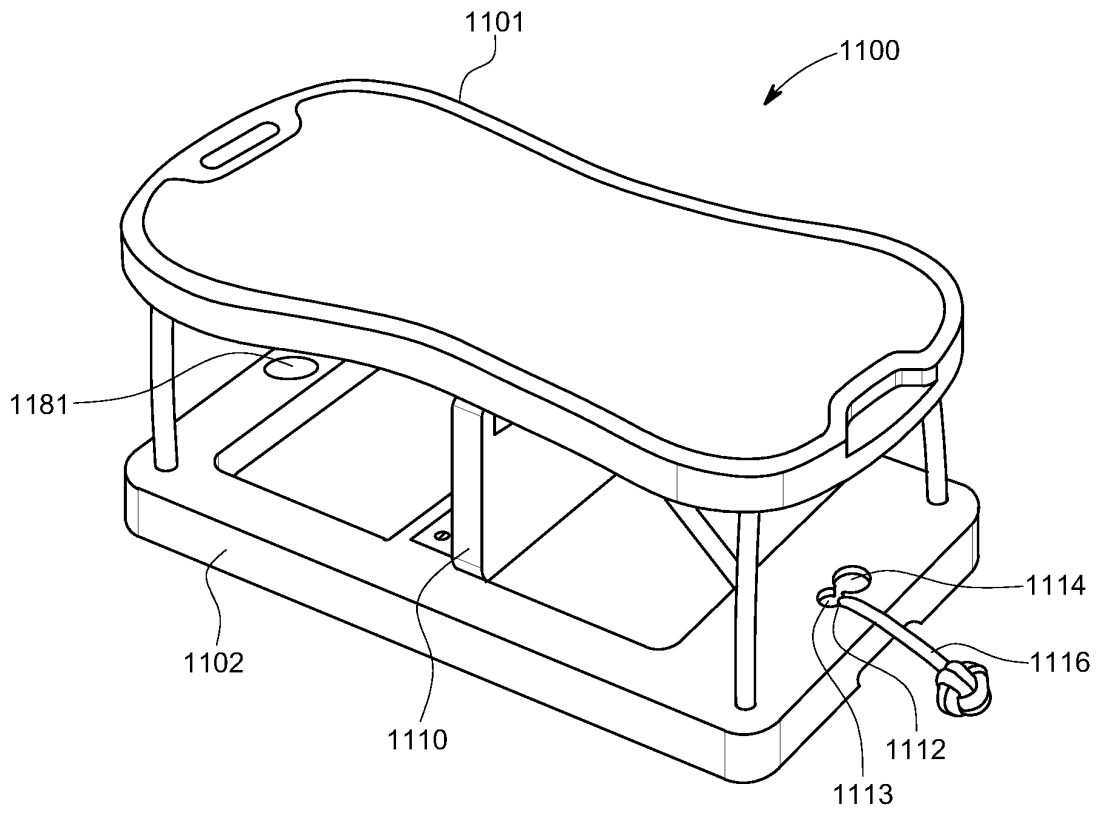

FIG. 30

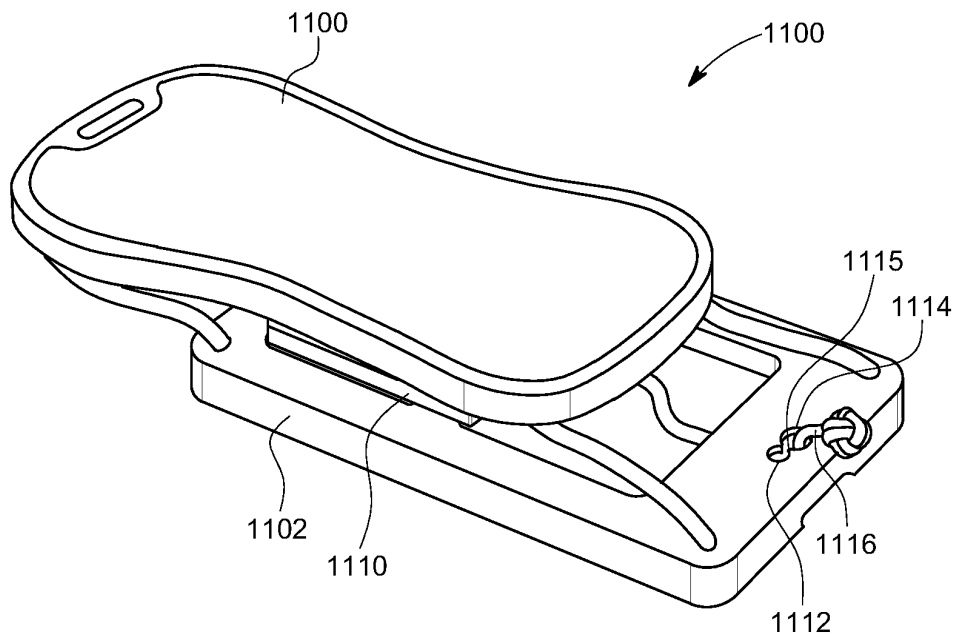

FIG. 31

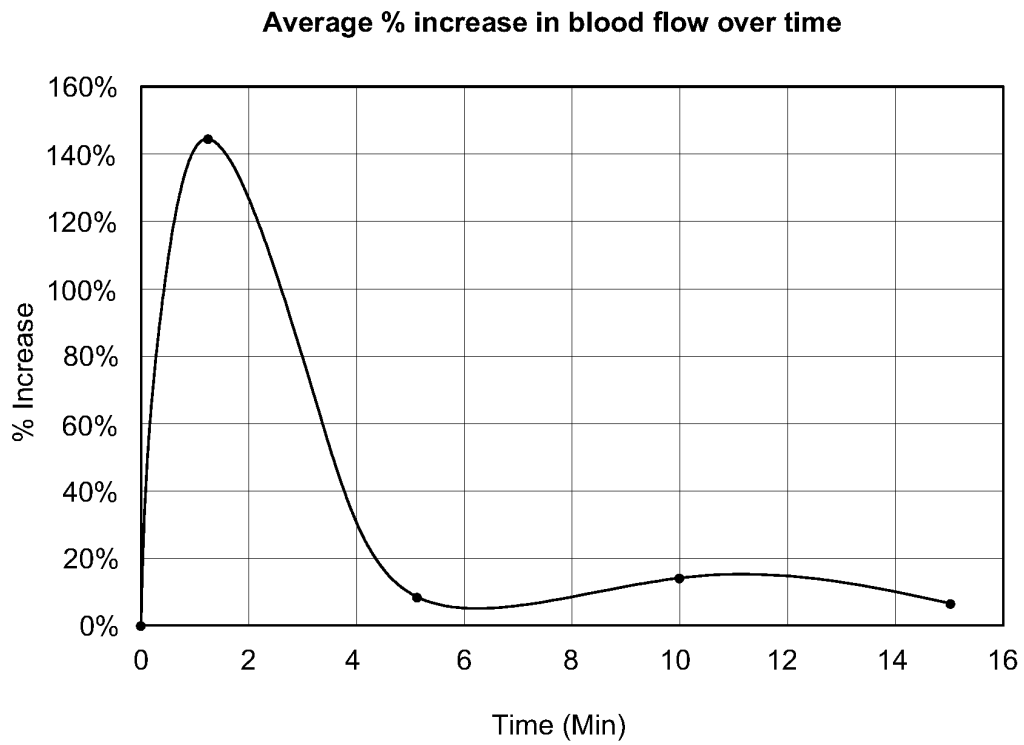

FIG. 32

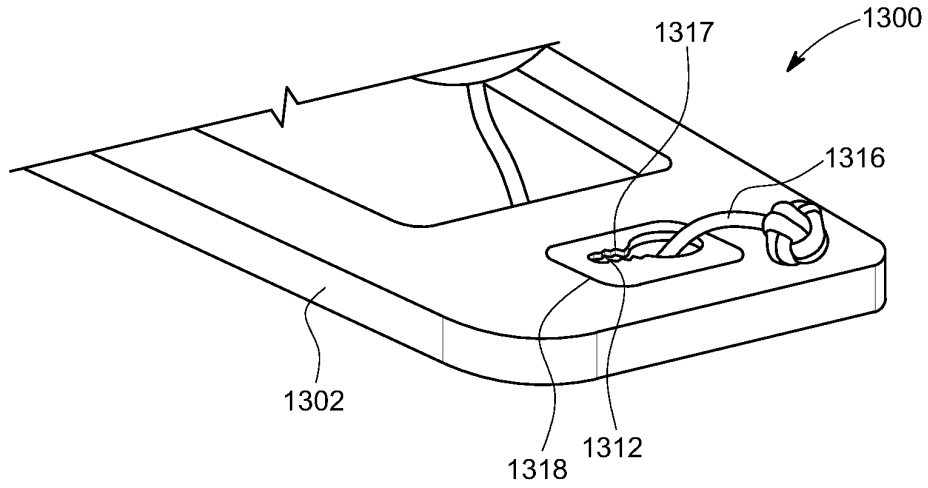

FIG. 33

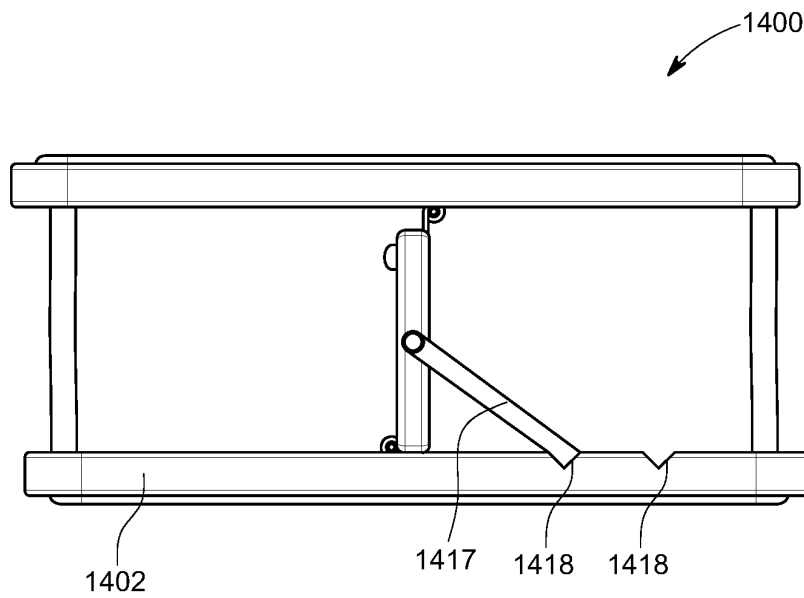

FIG. 34

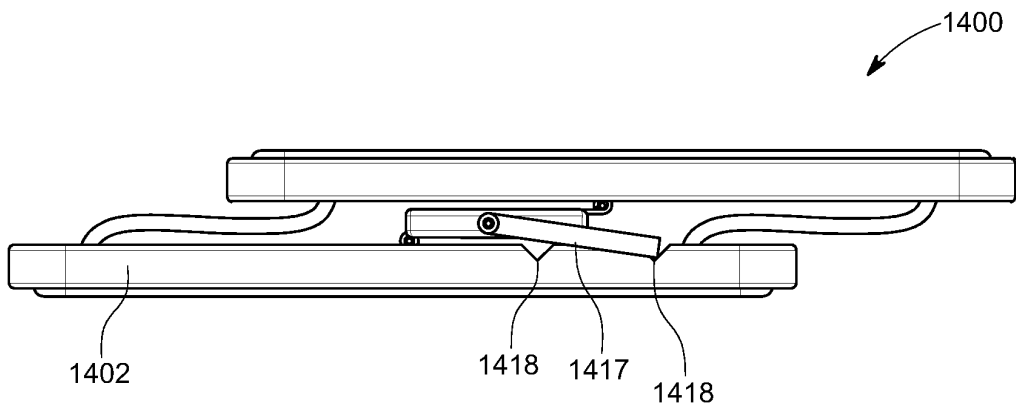

FIG. 35

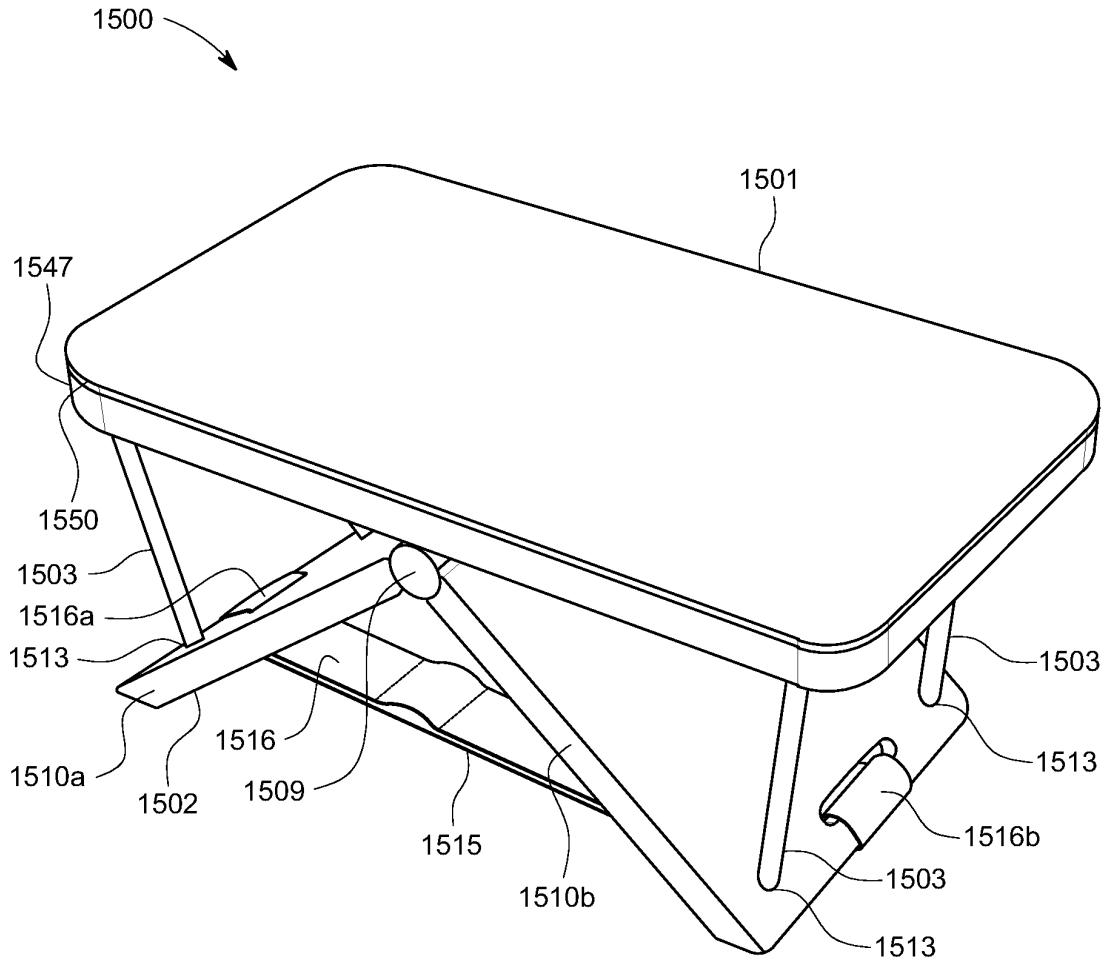

FIG. 36

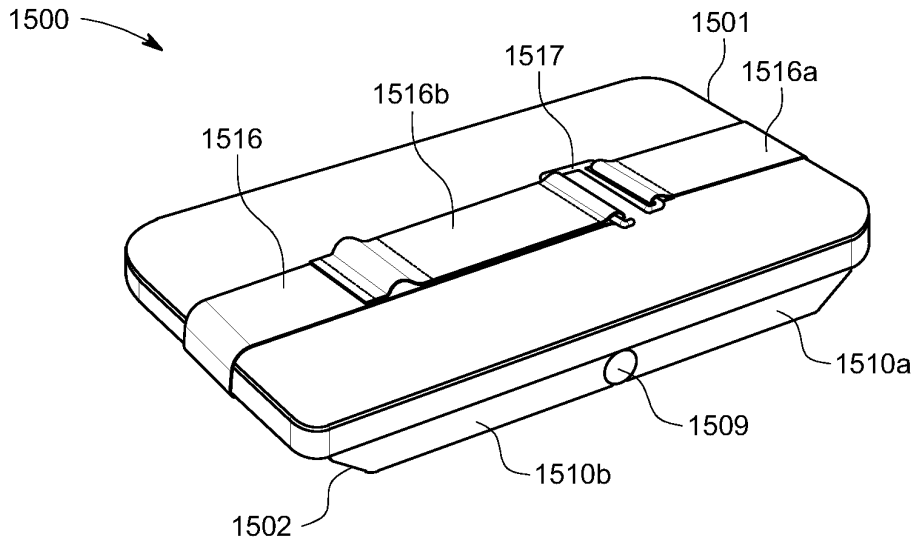

FIG. 37

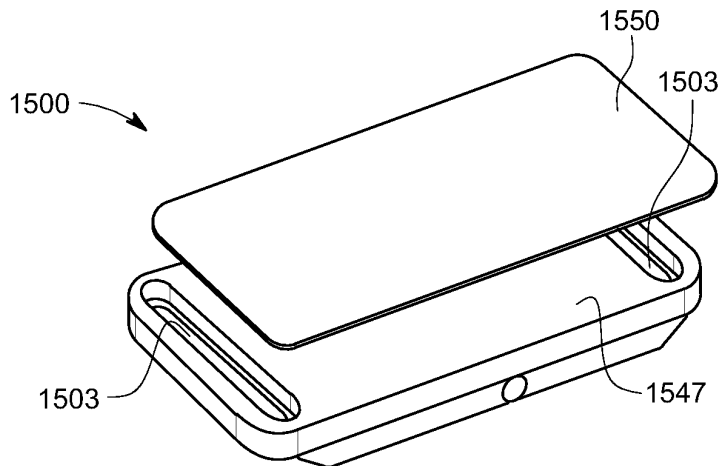

FIG. 38

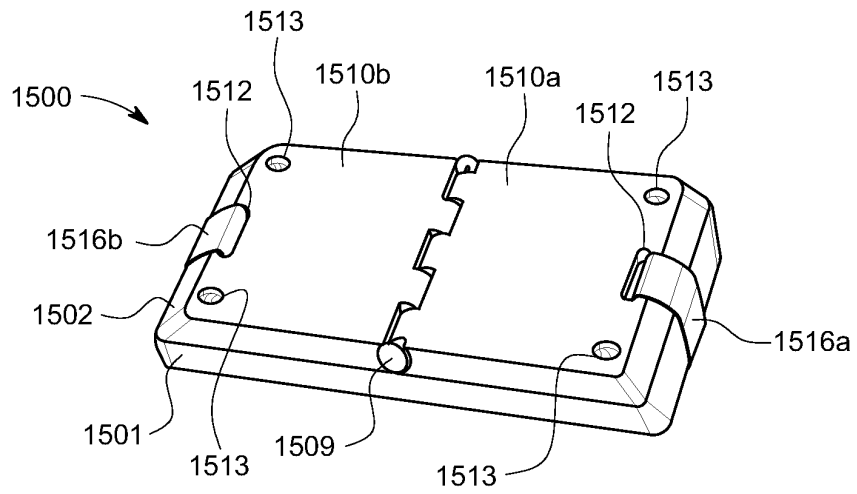

FIG. 39

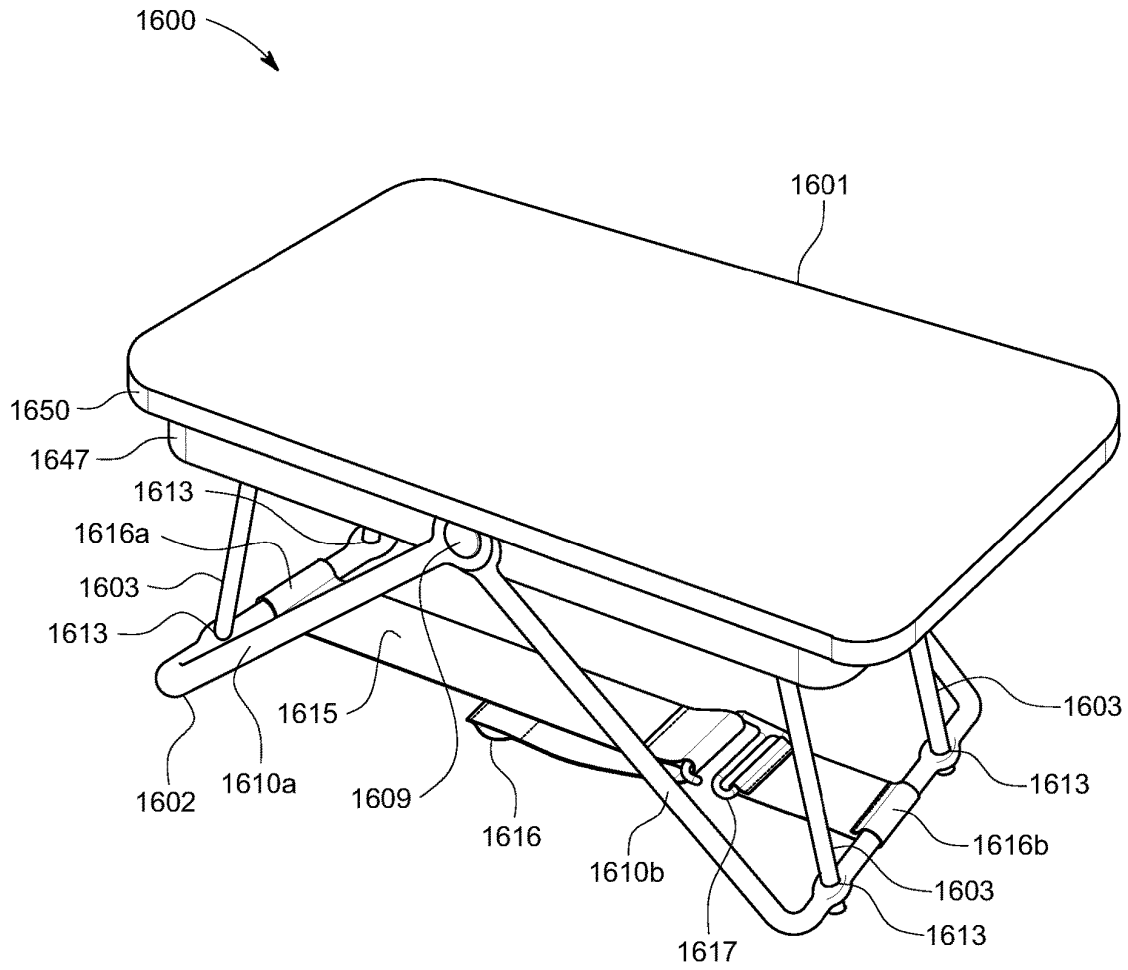

FIG. 40

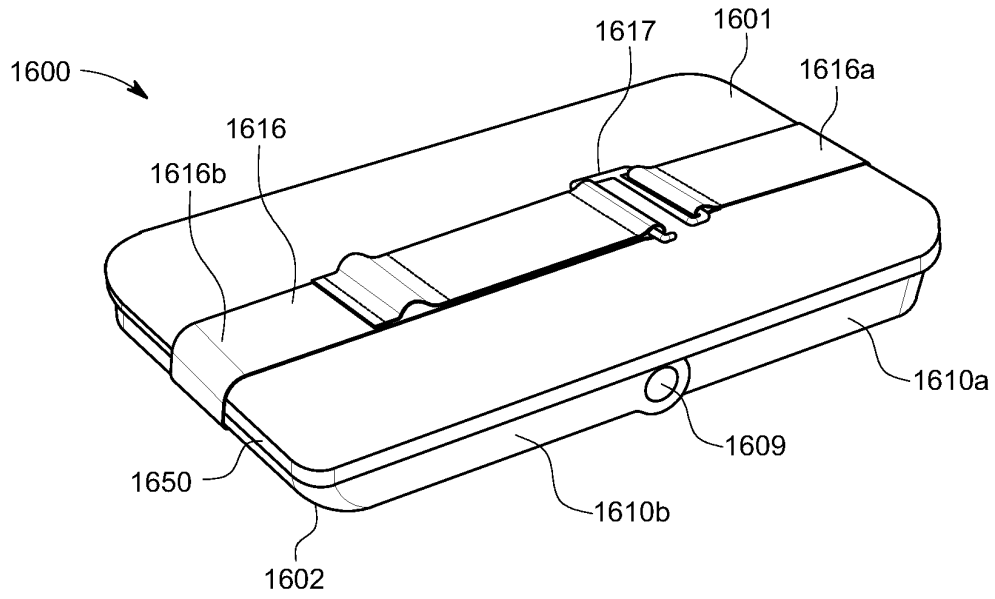

FIG. 41

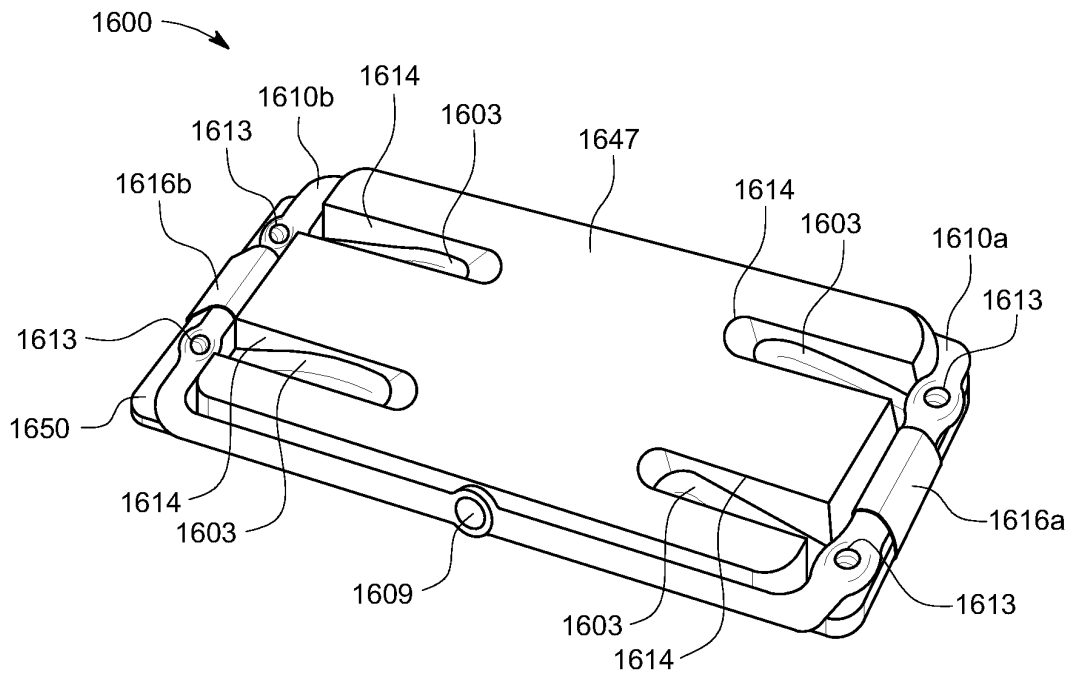

FIG. 42

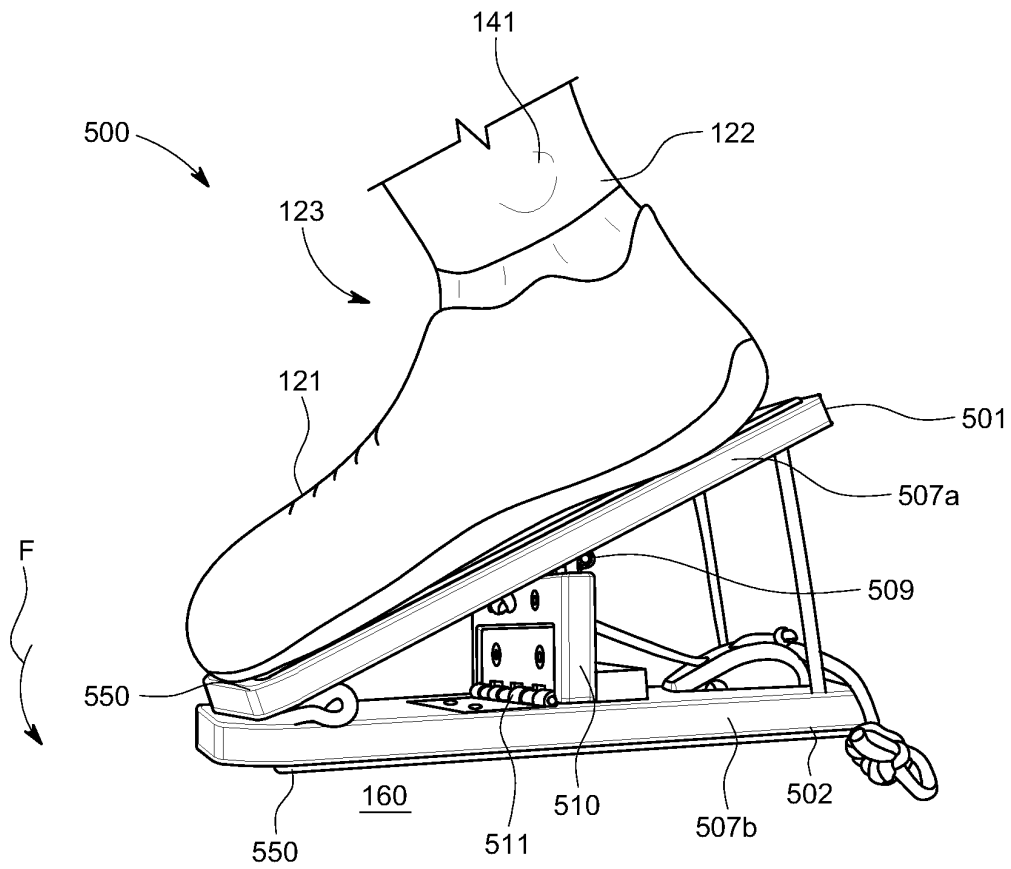

FIG. 43A

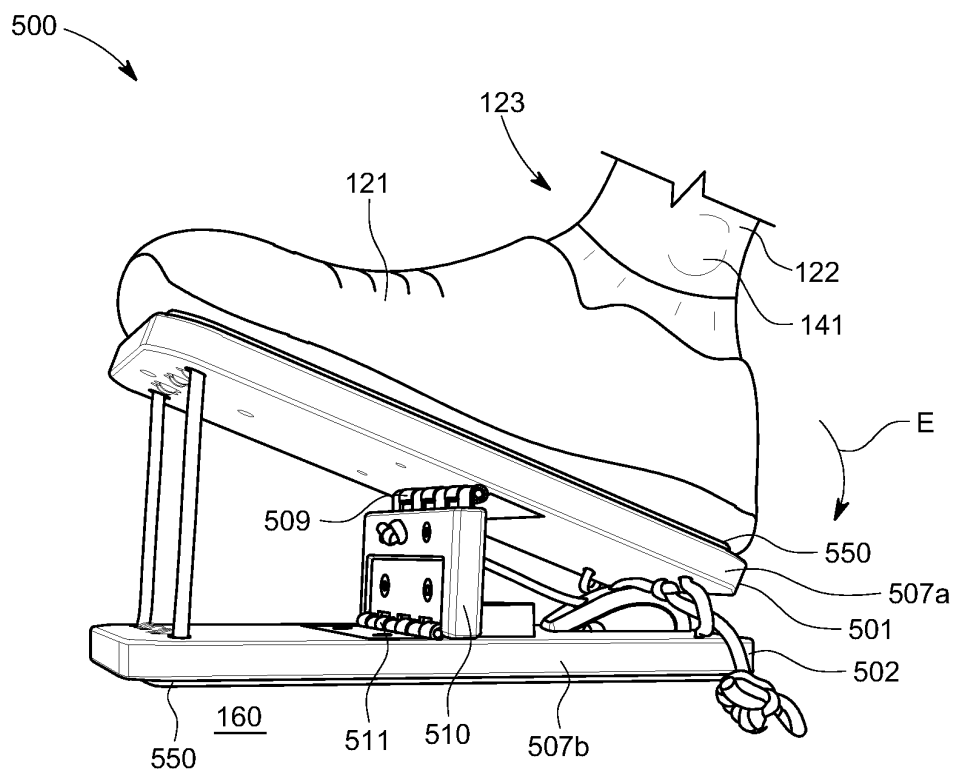

FIG. 43B

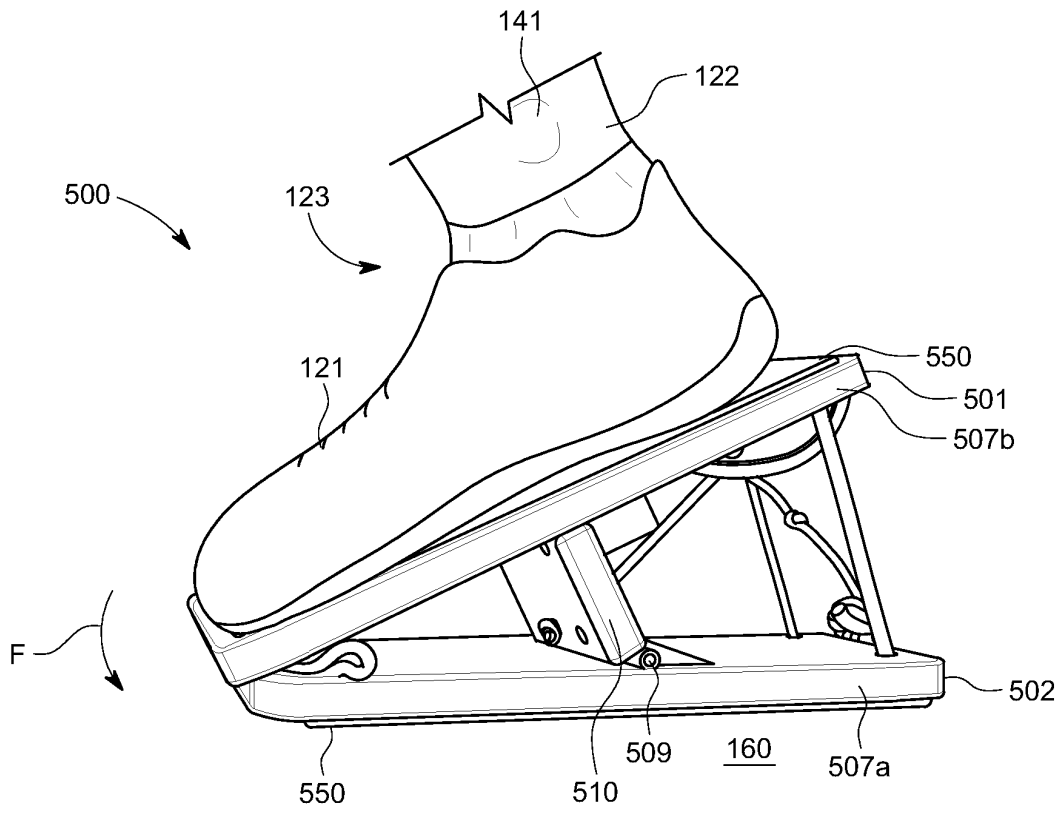

FIG. 44A

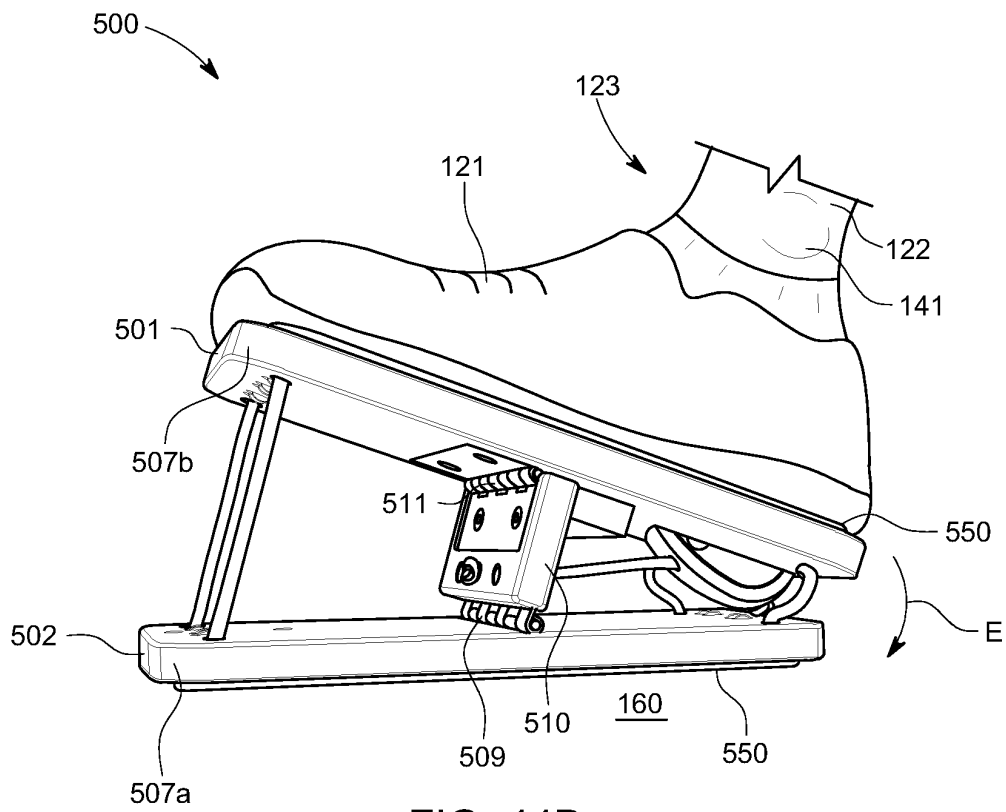

FIG. 44B

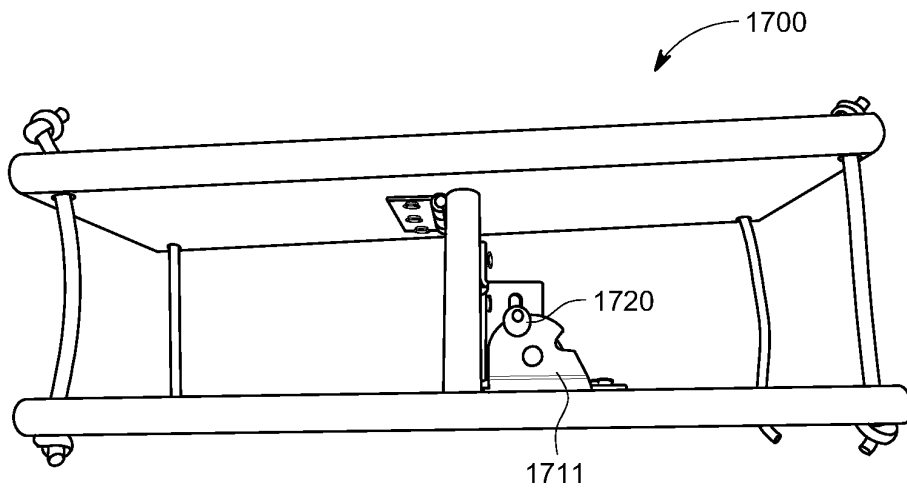

FIG. 45

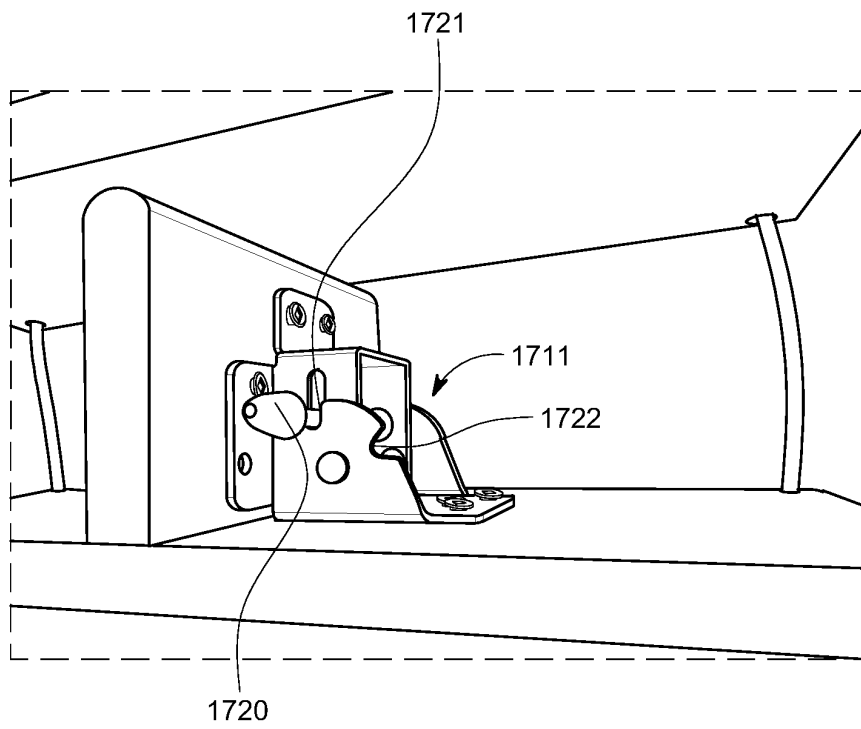

FIG. 46

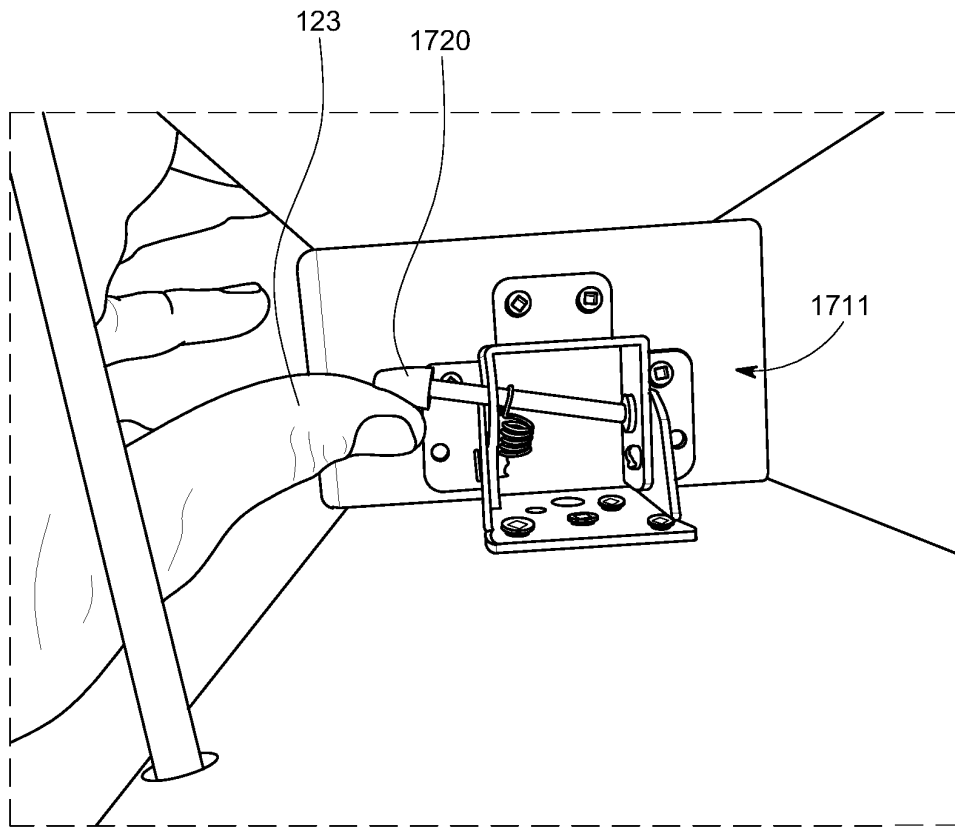

FIG. 47

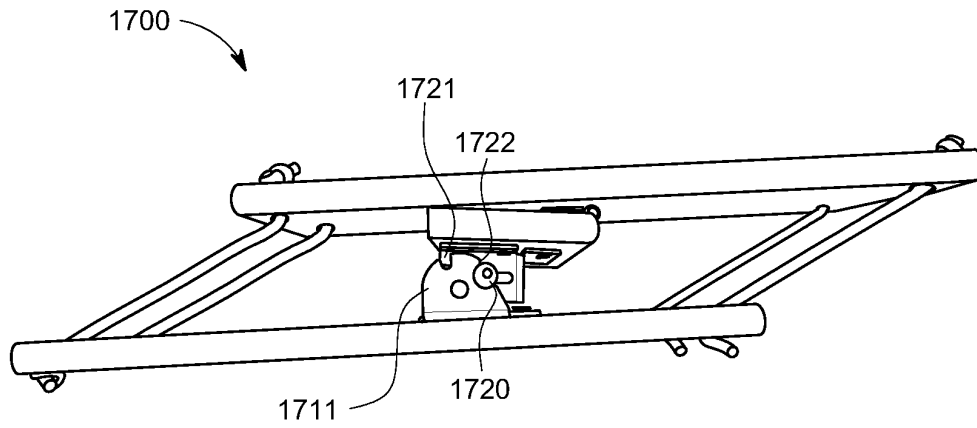

FIG. 48

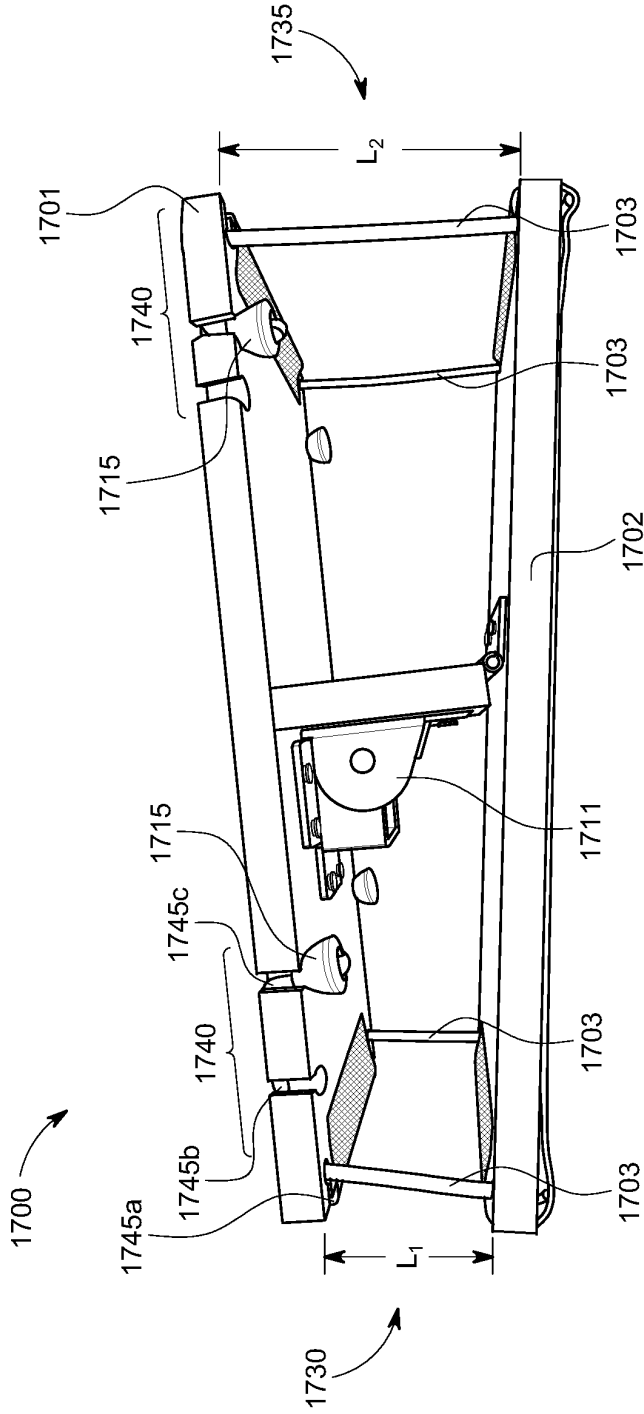

FIG. 49

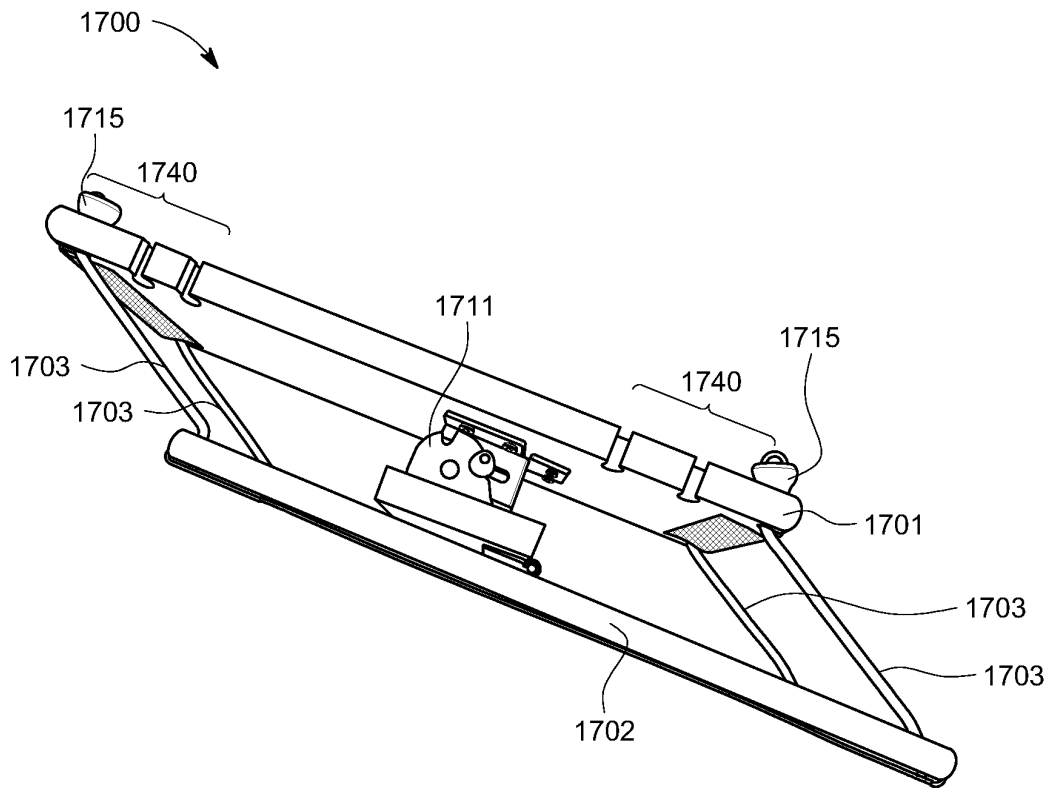

FIG. 50

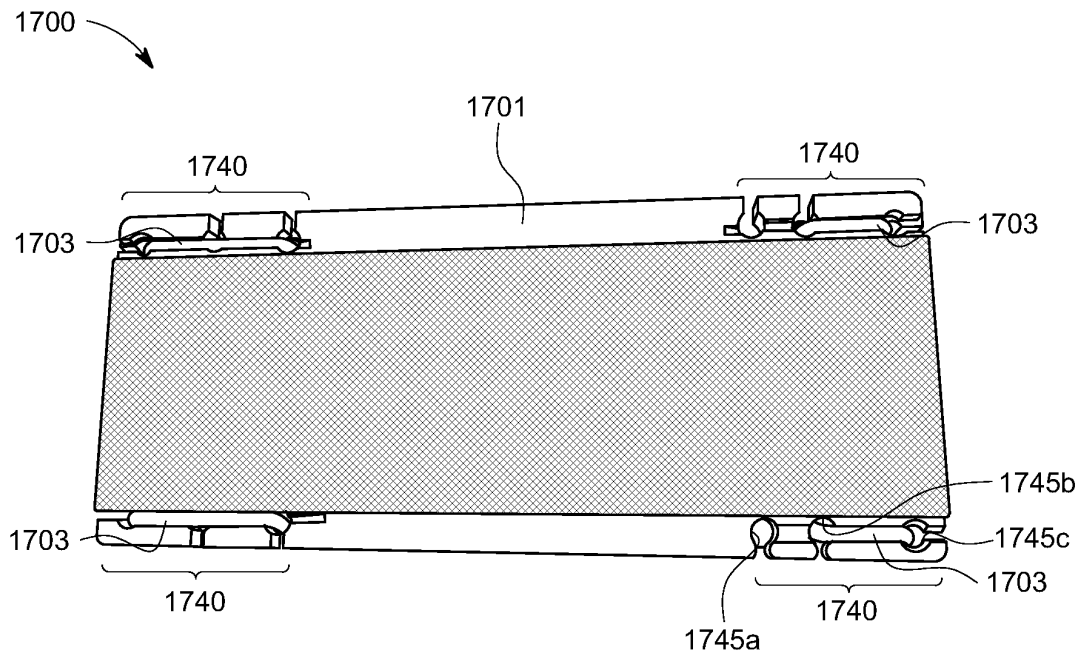

FIG. 51

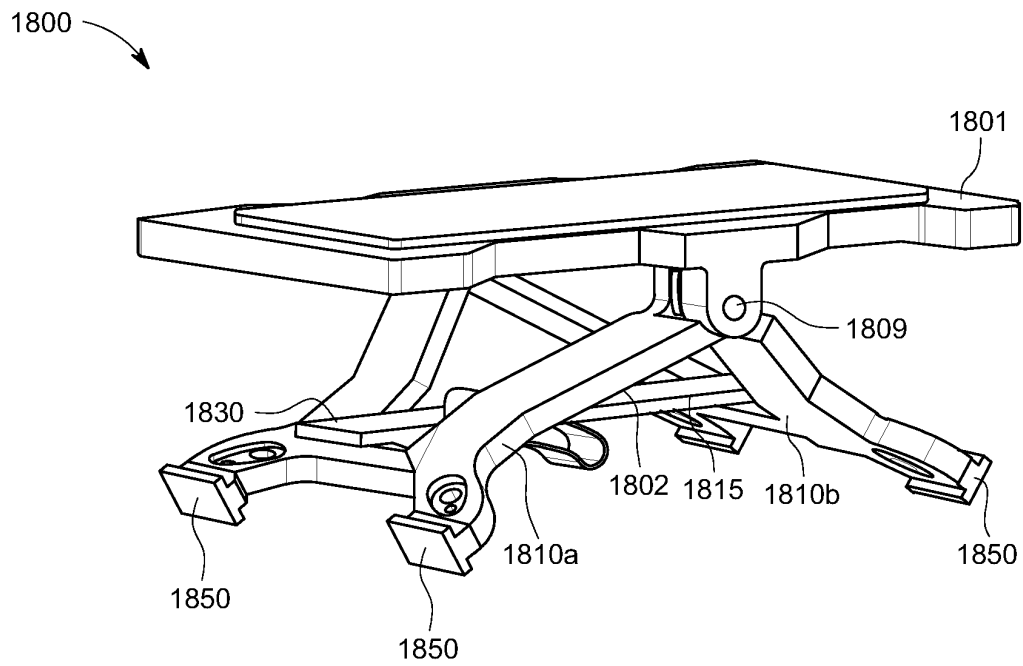

FIG. 52

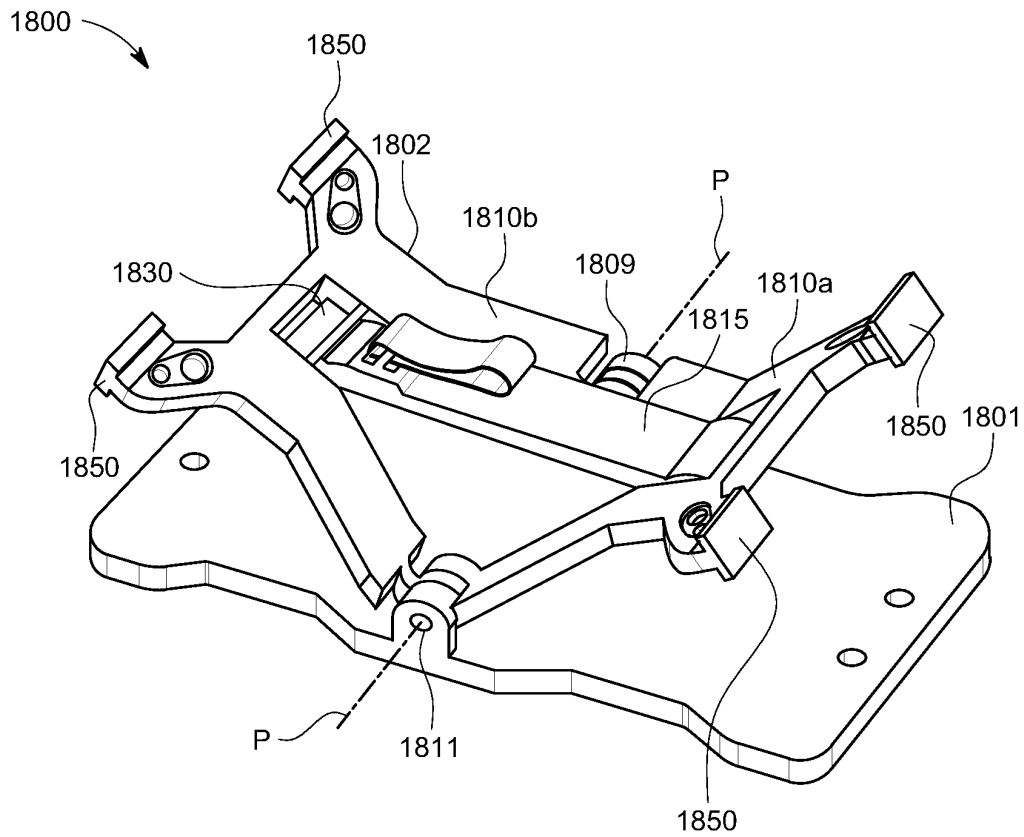

FIG. 53

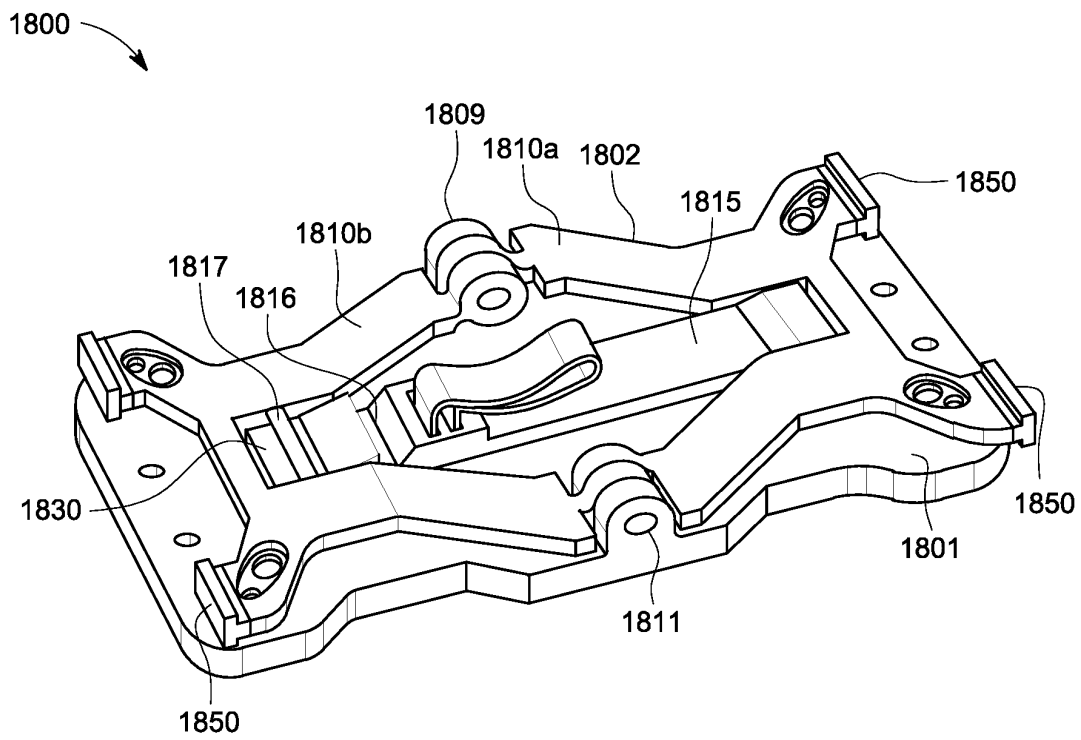

FIG. 54

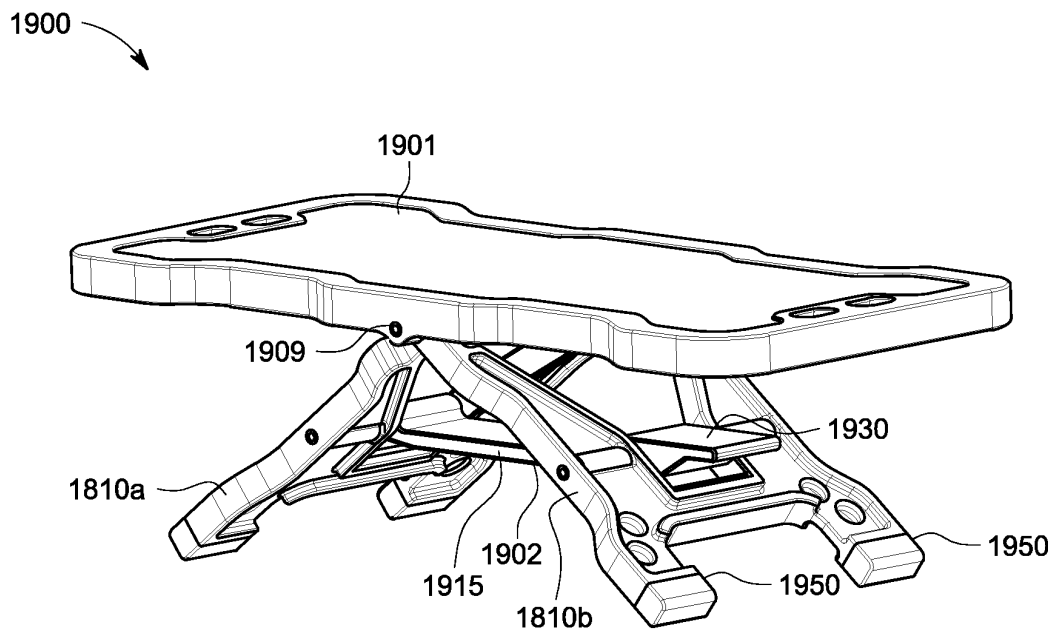

FIG. 55

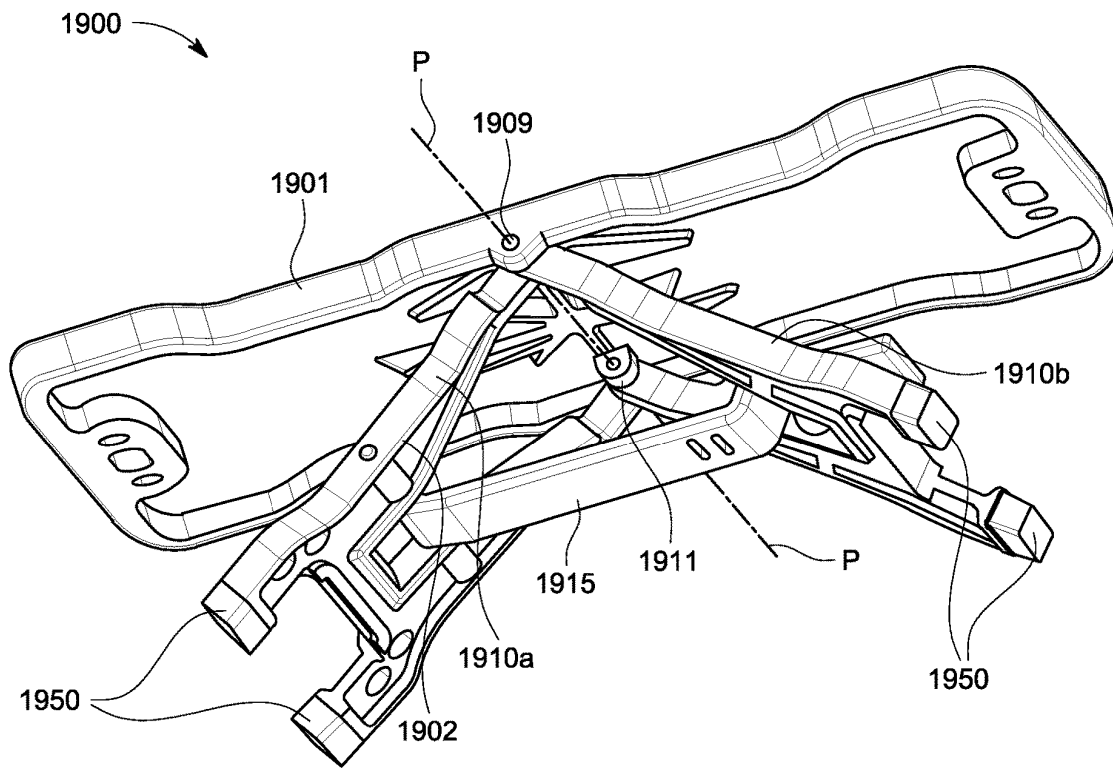

FIG. 56

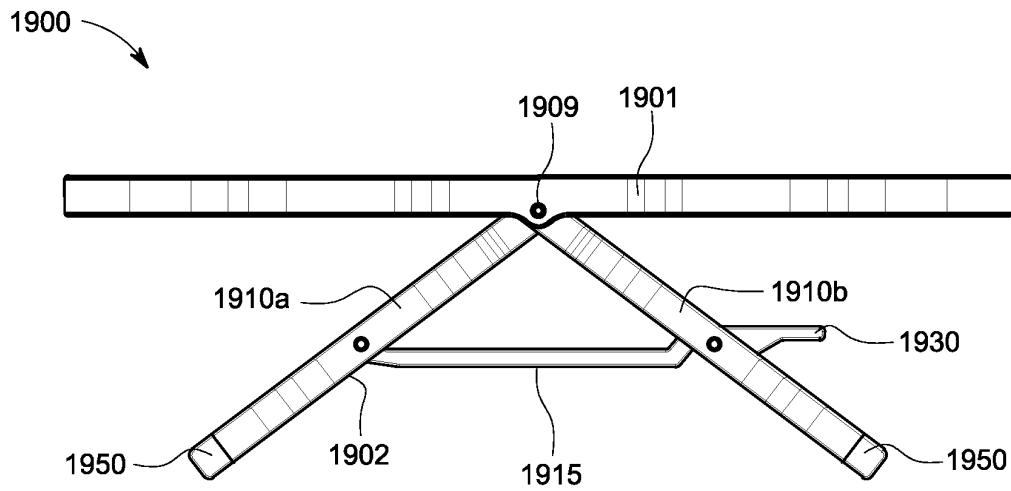

FIG. 57

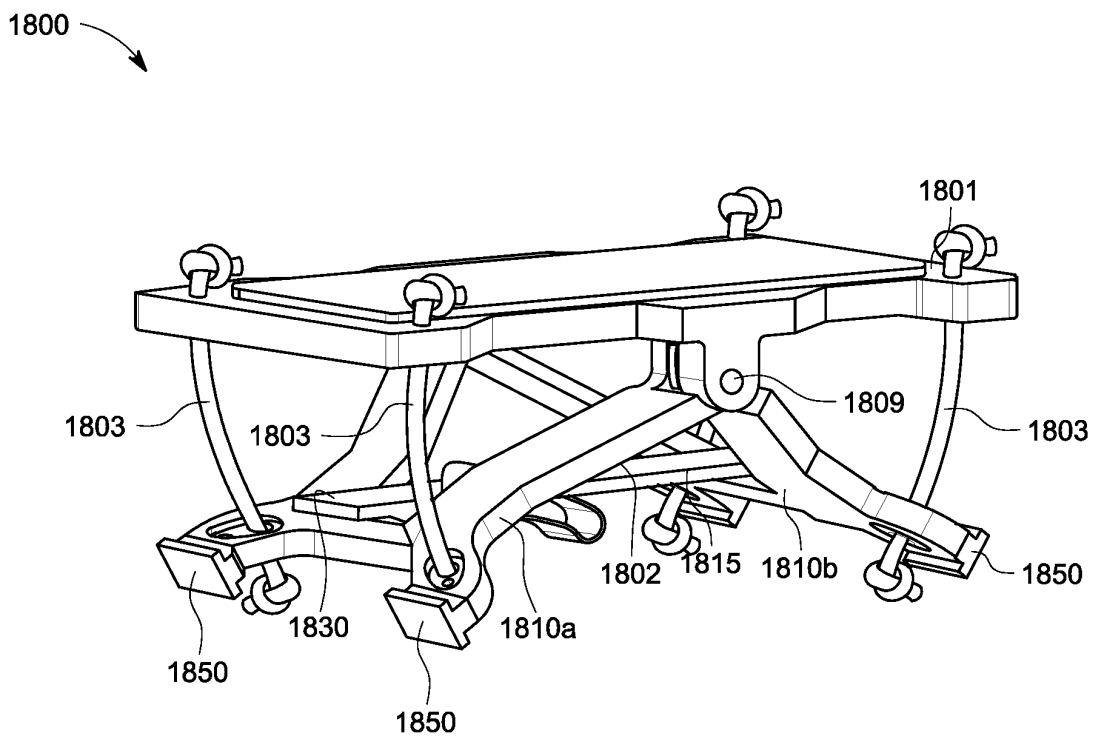

FIG. 58

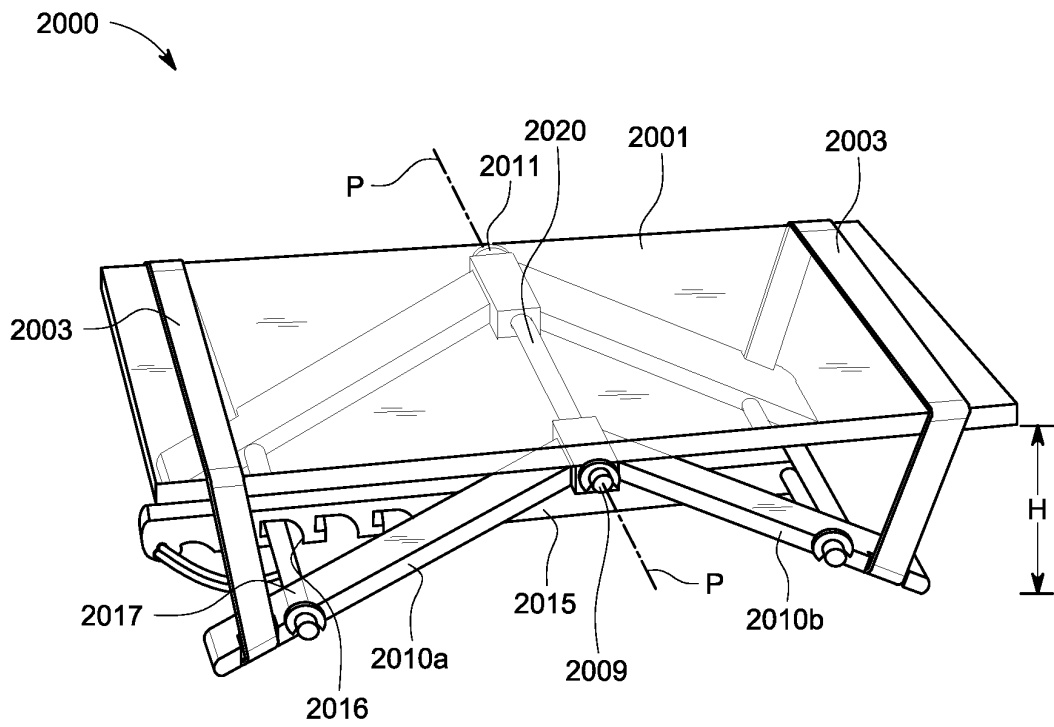

FIG. 59

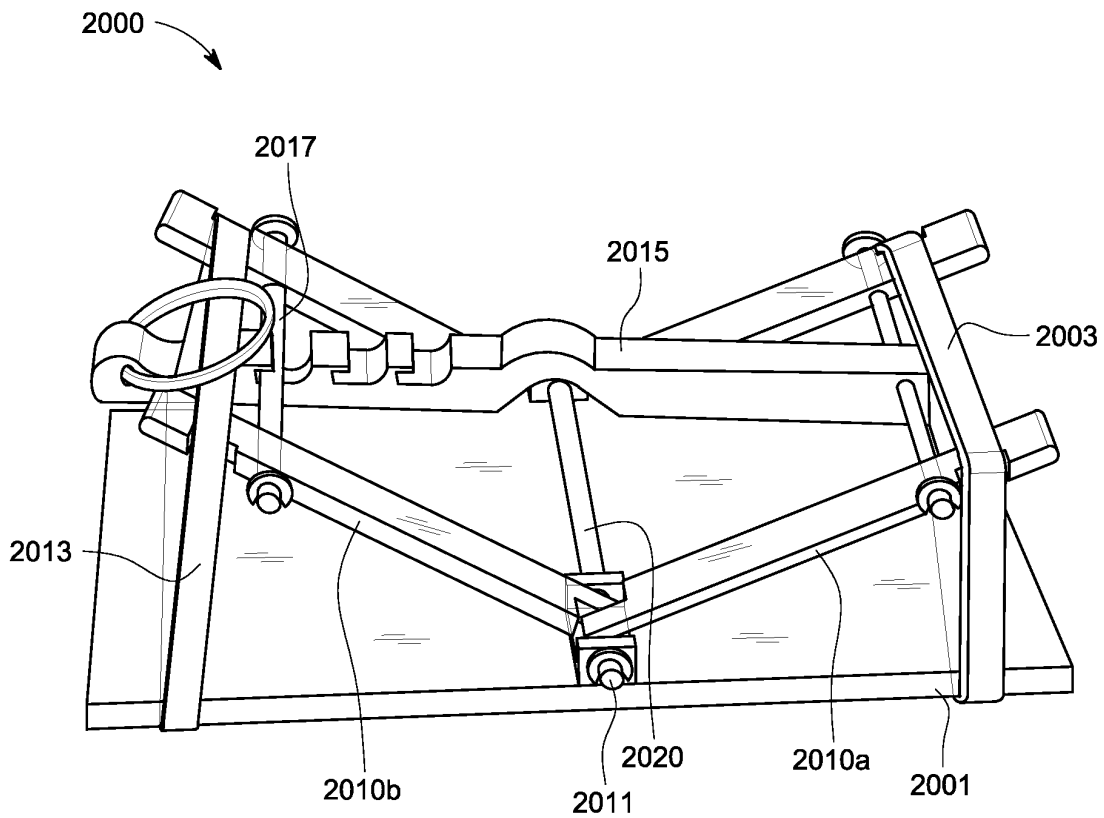

FIG. 60

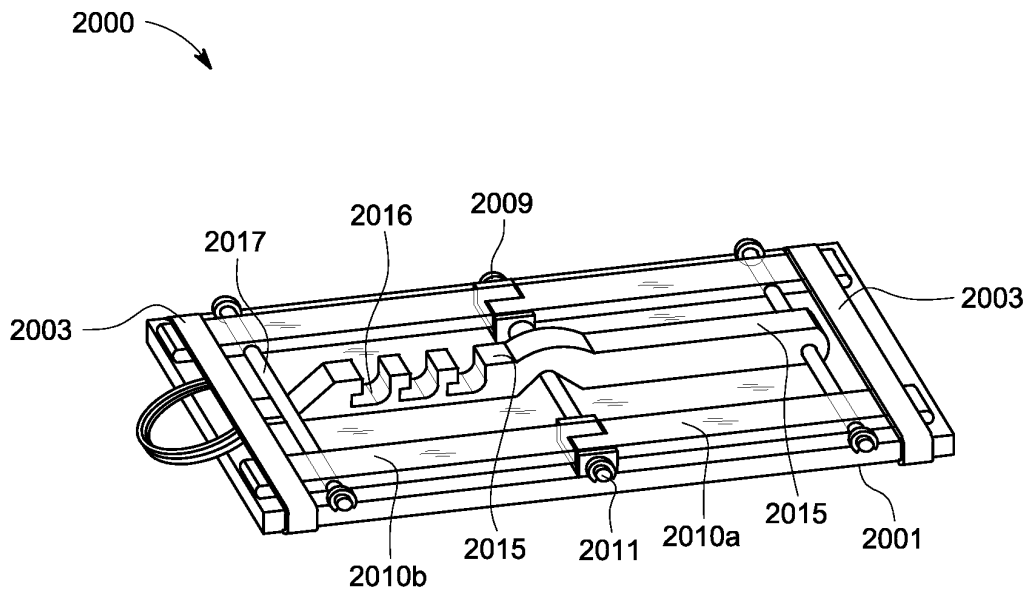

FIG. 61

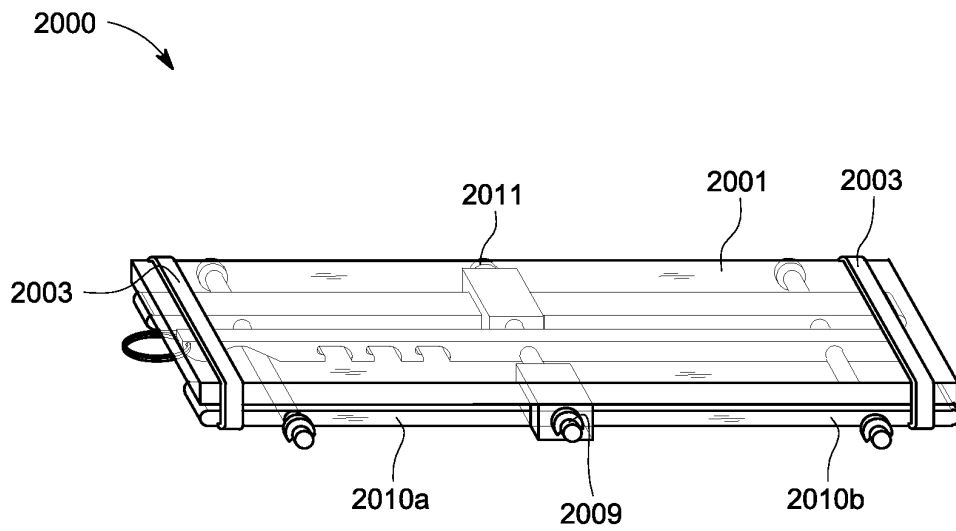

FIG. 62

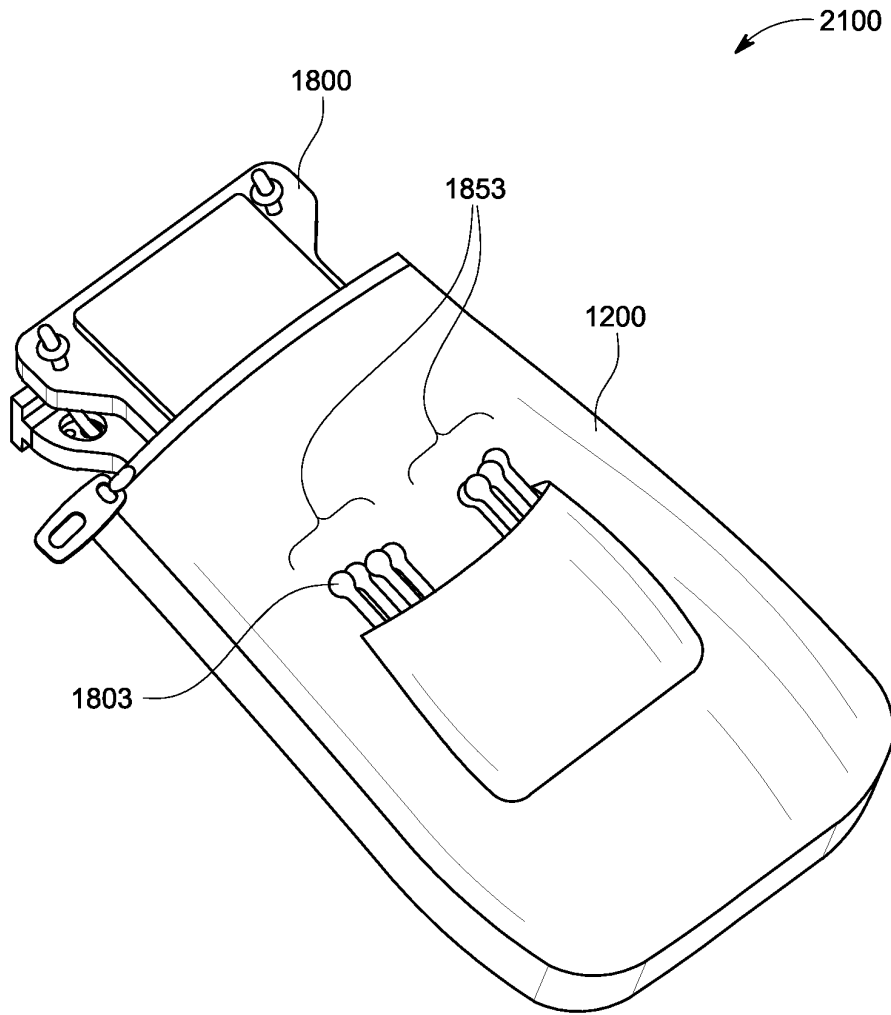

FIG. 63

**PORTABLE DEVICES FOR EXERCISING
MUSCLES IN THE ANKLE, FOOT, AND/OR
LEG, AND RELATED METHODS**

**CROSS-REFERENCE TO RELATED
APPLICATIONS**

This application is a divisional application of U.S. patent application Ser. No. 16/570,817, filed Sep. 13, 2019, now U.S. Pat. No. 11,207,559, which claims benefit to U.S. Provisional Application No. 62/731,647, filed Sep. 14, 2018 and entitled "Portable Devices for Exercising Muscles in the Ankle, Foot, and/or Leg, and Related Methods," the entire contents each of which is incorporated by reference herein. This Application is related to U.S. patent application Ser. No. 16/570,742, filed Sep. 13, 2019, now U.S. Pat. No. 10,702,740, and entitled Portable Devices for Exercising Muscles in the Ankle, Foot, and/or Leg, and Related Methods," the entire content of which is incorporated by reference herein.

TECHNICAL FIELD

The present disclosure relates to portable devices for exercising muscles in the ankle, foot, and/or leg, and related methods. More particularly, the present disclosure relates to portable devices, and related methods, for exercising muscles in the ankle, foot, and/or leg of a user to increase blood circulation, which may, for example, assist in preventing venous thromboembolism.

INTRODUCTION

The section headings used herein are for organizational purposes only and are not to be construed as limiting the subject matter described in any way.

Venous thromboembolism (VTE) occurs when red blood cells, fibrin and, to a lesser extent, platelets and leukocytes, form a mass (i.e., clot) within an intact vein. The thrombus (i.e., blood clot) is referred to as a deep venous thrombosis (DVT) when formed within the deep veins of the legs or in the pelvic veins. A pulmonary embolism (PE) results when a piece of thrombus detaches from a vein wall, travels to the lungs, and lodges within the pulmonary arteries.

VTE is often a concern in situations where an individual is immobile and/or relatively nonambulatory for a relatively long period of time, such as, for example, during hospitalization, after surgery, during pregnancy and/or in the postpartum period, while traveling (e.g., in a car, plane and/or train), at work, and/or in a more sedentary lifestyle (e.g., the elderly and/or obese). Blood returning to the heart does so through veins. Large veins, such as those found in the legs, lie near and between muscles and contain valves that maintain the flow of blood in the direction of the heart by preventing backflow and stasis. The contraction of these muscles (e.g., through walking) forces the blood through the veins in the direction of the heart, usually against the force of gravity, thereby preventing blood from accumulating in the extremities. If these muscles are not used and/or minimally (e.g., infrequently) used for an extended period of time, however, the lower limbs may swell with stationary blood, greatly increasing the risk of VTE.

Because of this potential danger, preventative measures against VTE have become standard, for example, in prolonged hospitalizations and postoperative care. Consequently, in conjunction with early ambulation, a number of prophylaxis devices have been developed to help prevent

VTE, including, for example, graduated compression stockings, intermittent pneumatic compression devices, and pneumatic compression devices. Such compressive techniques, however, fail to treat and articulate a patient's ankle and/or knee joints, or otherwise contract the ankle, foot and/or leg (e.g., calf) muscles. These devices and methods, therefore have limited exercise and therapy capabilities, and are generally impractical for use outside of a hospital setting.

Various additional exercise devices serve to articulate a patient's joints, thereby providing joint therapy while contracting the muscles of the ankle, foot, and/or leg to prevent blood from accumulating in the lower extremities of the body. Such devices, however, often fail to allow both full flexion and extension of a user's ankle, to provide both plantar flexion (i.e., movement which increases the approximate 90° angle between the front part of the foot and the shin, thereby contracting the calf muscle) and dorsiflexion motion (i.e., movement which decreases the angle between the front part of the foot and the shin, thereby stretching the calf muscle). Furthermore, many of these devices are bulky, cumbersome, complex and expensive; being impractical for use during transition care or between care locations, or for use by other VTE at-risk groups, such as, for example, travelers.

Due to growing concerns over the continued prevalence of VTE related medical cases, it may be desirable to provide a relatively simple, inexpensive device and method with full exercise and therapy capabilities, which allows for full flexion and extension of a user's ankle joint, while also being lightweight and compact. It also may be desirable to provide a device that is portable, being useful for all VTE at-risk individuals.

SUMMARY

The present disclosure may solve one or more of the above-mentioned problems and/or may demonstrate one or more of the above-mentioned desirable features. Other features and/or advantages may become apparent from the description that follows.

In accordance with various exemplary embodiments of the present disclosure, a method for exercising muscles in an ankle, foot, and/or leg of a user includes positioning a foot of a user onto a first body of an exercise device. The first body is spaced away from a second body of the device and pivotably connected to the second body of the device at a pivot axis. The pivot axis is adjacent to a central portion of the first body. The method also includes rotating the first body about the pivot axis, with the foot, against a first resistive force, wherein rotating the first body includes subjecting the foot to a first motion. The method also includes positioning the foot onto the second body. The method further includes rotating the second body about the pivot axis, with the foot, against a second resistive force, wherein rotating the second body comprises subjecting the foot to a second motion, the second motion being different than the first motion.

In accordance with various additional exemplary embodiments of the present disclosure a method for exercising muscles in an ankle, foot, and/or leg of a user includes, with a second body of an exercise device positioned on a support surface, the second body being substantially parallel to and spaced away from a first body of the device and pivotably connected to the first body of the device via a movable support structure, positioning a foot of a user onto the first body of the exercise device. The method also includes rotating the first body about a pivot axis, with the foot, while

keeping the support structure substantially stationary, wherein rotating the first body includes subjecting the foot to a first motion. The method also includes, with the first body of the exercise device positioned on the support surface, the first body being substantially parallel to and spaced away from the second body of the device, positioning the foot of the user onto the second body. The method further includes rotating the second body about the pivot axis, with the foot, while moving the support structure, wherein rotating the second body includes subjecting the foot to a second motion, the second motion being different than the first motion.

Additional objects and advantages will be set forth in part in the description which follows, and in part will be obvious from the description, or may be learned by practice of the present disclosure. The objects and advantages may be realized and attained by means of the elements and combinations particularly pointed out in the appended claims and their equivalents.

It is to be understood that both the foregoing general description and the following detailed description are exemplary and explanatory only and are not restrictive of the present disclosure and claims.

BRIEF DESCRIPTION OF THE DRAWINGS

The present disclosure can be understood from the following detailed description either alone or together with the accompanying drawings. The drawings are included to provide a further understanding, and are incorporated in and constitute a part of this specification. The drawings illustrate one or more exemplary embodiments of the present disclosure and together with the description serve to explain various principles and operations.

FIG. 1 is a perspective top, front view of an exemplary embodiment of a portable exercise device, in an open configuration, in accordance with the present disclosure;

FIG. 2 is a perspective side, back view of the device of FIG. 1 in the open configuration;

FIG. 3 is a side view of the device of FIG. 1 in the open configuration;

FIG. 4 is a front view of the device of FIG. 1 in the open configuration;

FIG. 5 is a back view of the device of FIG. 1 in the open configuration;

FIG. 6 is a side view of the device of FIG. 1 in the open configuration, showing a user's foot strapped to the device for use in a sitting position;

FIG. 7 is a side view of the device of FIG. 1 in the open configuration, showing a user's foot strapped to the device for use in a supine position.

FIG. 8 is a perspective top, front view of the device of FIG. 1 in a closed configuration;

FIG. 9 is a perspective side, back view of the device of FIG. 1 in the closed configuration;

FIG. 10 is a side view of the device of FIG. 1 in the closed configuration;

FIG. 11 is a front view of the device of FIG. 1 in the closed configuration;

FIG. 12 is a back view of the device of FIG. 1 in the closed configuration;

FIG. 13A is a perspective side view of another embodiment of a portable exercise device, in an open configuration, in accordance with the present disclosure, showing a user rotating a pedal of the device in a first direction;

FIG. 13B is a perspective side view of the device of FIG. 12B in the open configuration, showing a user rotating a pedal of the device in a second direction;

FIG. 14 is a diagram of an exemplary range of motion of the portable exercise devices in accordance with the present disclosure;

FIG. 15 is a perspective view of another embodiment of a portable device, in an open configuration, in accordance with the present disclosure;

FIG. 16 is a perspective view of another embodiment of a portable device, in an open configuration, in accordance with the present disclosure;

FIG. 17 is a perspective view of yet another embodiment of a portable device, in an open configuration, in accordance with the present disclosure;

FIG. 18 is a perspective top view of yet another embodiment of a portable exercise device, in an open configuration, in accordance with the present disclosure;

FIG. 19 is a perspective side, front view on the device of FIG. 18 in the open configuration;

FIG. 20 is a perspective side view of the device of FIG. 18 in the open configuration;

FIG. 21 is a perspective side, top view of the device of FIG. 18 in a closed configuration;

FIG. 22 is a perspective top, front view of another embodiment of a portable exercise device, in an open configuration, in accordance with the present disclosure;

FIG. 23 is a perspective top, front view of yet another embodiment of a portable exercise device, in an open configuration, in accordance with the present disclosure;

FIG. 24 is a perspective top, front view of an additional embodiment of a portable exercise device, in an open configuration, in accordance with the present disclosure;

FIG. 25 is a perspective top, front view of another embodiment of a portable exercise device, in an open configuration, in accordance with the present disclosure;

FIG. 26 is a perspective top, front view of the device of FIG. 25 in a closed configuration;

FIG. 27 is a top, front view of the device of FIG. 25 in a closed configuration and partially inserted into an exemplary pouch in accordance with the present disclosure;

FIG. 28 is a perspective top, front view of another embodiment of a portable exercise device, in an open configuration, in accordance with the present disclosure;

FIG. 29 is a perspective top, front view of the device of FIG. 28 in a closed configuration;

FIG. 30 is a perspective top, front view of another embodiment of a portable exercise device, in an open configuration, in accordance with the present disclosure;

FIG. 31 is a perspective top, front view of the device of FIG. 30 in a closed configuration;

FIG. 32 is a graph illustrating the average percentage increase in blood flow over time during use of an exercise device in accordance with the present disclosure;

FIG. 33 is a partial, perspective top, front view of another embodiment of a portable exercise device in accordance with the present disclosure;

FIG. 34 is a side view of another exemplary embodiment of a portable exercise device, in an open configuration, in accordance with the present disclosure;

FIG. 35 is a side view of the device of FIG. 34 in a closed configuration;

FIG. 36 is a perspective top, front view of another embodiment of a portable exercise device, in an open configuration, in accordance with the present disclosure;

FIG. 37 is a perspective top, back view of the device of FIG. 36 in a closed configuration;

5

FIG. 38 is a partially exploded, perspective top, back view of the device of FIG. 36 in the closed configuration;

FIG. 39 is a perspective bottom view of the device of FIG. 36 in the closed configuration;

FIG. 40 is a perspective top, front view of another embodiment of a portable exercise device, in an open configuration, in accordance with the present disclosure;

FIG. 41 is a perspective top, front view of the device of FIG. 40 in a closed configuration;

FIG. 42 is a perspective bottom view of the device of FIG. 40 in the closed configuration;

FIG. 43A is a perspective side view of the device of FIG. 18, in a first open configuration, in accordance with the present disclosure, showing a user rotating a pedal of the device in a first direction;

FIG. 43B is a perspective side view of the device of FIG. 18 in the first open configuration, showing a user rotating a pedal of the device in a second direction;

FIG. 44A is a perspective side view of the device of FIG. 18, in a second open configuration, in accordance with the present disclosure, showing a user rotating a pedal of the device in a first direction;

FIG. 44B is a perspective side view of the device of FIG. 18 in the second open configuration, showing a user rotating a pedal of the device in a second direction;

FIG. 45 is a perspective side view of another exemplary embodiment of a portable exercise device, in an open configuration, in accordance with the present disclosure;

FIG. 46 is an enlarged, partial perspective side, back view of the device of FIG. 45 showing a self-locking hinge in accordance with the present disclosure;

FIG. 47 is an enlarged, partial perspective back view of the device of FIG. 45 illustrating operation of the self-locking hinge;

FIG. 48 is a perspective side view of the device of FIG. 45, in a closed configuration;

FIG. 49 is a perspective side view of another exemplary embodiment of a portable exercise device, in an open configuration, in accordance with the present disclosure;

FIG. 50 is a perspective side view of the device of FIG. 49, in a closed configuration;

FIG. 51 is a top view of the device of FIG. 49;

FIG. 52 is a perspective side, front view of another exemplary embodiment of a portable exercise device, in an open configuration, in accordance with the present disclosure;

FIG. 53 is a perspective side, bottom view of the device of FIG. 52, in the open configuration;

FIG. 54 is a perspective bottom view of the device of FIG. 52, in a closed configuration;

FIG. 55 is a perspective side, top view of another exemplary embodiment of a portable exercise device, in an open configuration, in accordance with the present disclosure;

FIG. 56 is a perspective side, bottom view of the device of FIG. 55, in the open configuration;

FIG. 57 is a side view of the device of FIG. 55, in the open configuration;

FIG. 58 is a perspective side, top view of yet another exemplary embodiment of a portable exercise device, in an open configuration, in accordance with the present disclosure

FIG. 59 is a perspective side, top view of yet another exemplary embodiment of a portable exercise device, in an open configuration, in accordance with the present disclosure;

FIG. 60 is a perspective side, bottom view of the device of FIG. 59, in the open configuration;

6

FIG. 61 is a perspective side, bottom view of the device of FIG. 59, in a closed configuration;

FIG. 62 is a perspective side, top view of the device of FIG. 59, in the closed configuration; and

FIG. 63 is a top, front view of an exemplary kit, including the device of FIG. 58, in accordance with the present disclosure.

DESCRIPTION OF VARIOUS EXEMPLARY EMBODIMENTS

Various conventional thromboprophylaxis techniques typically rely on devices that are cumbersome, complex, and/or expensive. Consequently, such devices are generally impractical for use during transition care or between care locations, or for use by other VTE vulnerable groups, such as, for example, expectant mothers, travelers and/or other individuals sitting for extended periods. To increase thromboprophylaxis utilization, various exemplary embodiments of the present disclosure provide portable devices for exercising an ankle, foot and/or leg, and methods of using such devices, that provide simple and relatively inexpensive prophylaxis by providing full flexion and extension of the ankle joint to increase circulation in the lower extremities of the body. Various exemplary embodiments of the present disclosure, therefore, provide portable exercise devices that may engage both calf muscle pump and venous foot pump to enhance the return of venous blood from the lower extremities to the heart. Increasing circulation may include increasing circulation in body tissues. Movement of bodily fluids, including blood, lymph, and/or interstitial fluids may be achieved through practice of the disclosed methods and use of the disclosed devices. The increased circulation may be found in one or more of blood vessels, the lymphatic system, muscles, interstitial spaces, capillaries and surrounding body tissues. In addition to the movement of fluids through ankle flexion and extension, the pressure applied to the sole of the foot during the exercise, i.e., plantar pressure, also contributes to movement of fluid through the body tissue and to an increase in circulation of bodily fluids. This plantar pressure can have a massaging effect that stimulates nerves, which may cause the release of certain biochemicals that reduce coagulation and dilation in the blood vessels.

In various exemplary embodiments, portable exercise devices for exercising an ankle, foot and/or leg, and related methods, use at least one pedal that is pivotably connected to a base about a pivot axis. The pedal has a neutral position relative to the pivot axis and is generally positioned such that the pivot axis is centrally located along a length of the pedal. When the pedal is in the neutral position, the pedal is substantially parallel to the base and there is a space between the pedal and the base. In this manner, the pedal is configured to rotate about the pivot axis in a first direction away from the neutral position and toward the base (where a first end of the pedal moves toward the base) and in a second direction away from the neutral direction and toward the base (where a second end of the pedal moves toward the base), wherein the second direction is opposite the first direction.

The devices and methods also use a resistance mechanism that is configured to exert a force on the pedal about the pivot axis in a direction opposite to a respective direction of rotation of the pedal about the pivot axis. For example, in accordance with various embodiments, to exercise the ankle, foot, and/or leg of the user, as explained further below, the force exerted by the resistance mechanism is configured to provide a passive resistance to the rotational movement of

the pedal. In other words, the resistance mechanism is configured to provide a passive resistance against the rotation of the pedal throughout a full range of ankle flexion and ankle extension.

In accordance with the present disclosure, a pivot axis of the device may be located at a point configured to be positioned below a user's ankle during use. In some embodiments, the pivot axis of the device may be located at a point configured to be positioned below a central portion of a user's foot during use, such that the user's foot undergoes a rocking motion as it moves through a full range of ankle flexion and ankle extension. In additional embodiments, as will be described further below, the device may provide two different types of movements, such that the device has a first movement relative to a first side of the device and a second movement relative to a second side of the device. In this manner, the device may be used in a first open, in-use configuration, and flipped over to be used in a second open, in-use configuration. Thus, in such embodiments, each of the first and second open, in-use configurations of the device may employ a different type of motion on the foot as it moves through the full range of ankle flexion and ankle extension.

As used herein, the term "full range of ankle flexion and ankle extension" refers to the complete range of motion that the joints of a healthy user's ankle may undergo. In accordance with exemplary embodiments of the present disclosure, as illustrated in FIG. 14, a full range of ankle flexion and extension includes about 75 degrees of plantar flexion motion p (e.g., rotation ranging from about neutral to 75 degrees); and about 60 degrees of dorsiflexion motion d (e.g., rotation ranging from about neutral to -60 degrees). It will be understood, however, that the ambulatory ability of a user may be limited, and that, accordingly, the range of ankle flexion and ankle extension of each individual user may vary and be somewhat to significantly less than the full range of ankle flexion and ankle extension.

Accordingly, as illustrated in the exemplary embodiments shown in the drawings, a portable exercise device in accordance with the present disclosure has a simple configuration, which includes three main parts: 1) a base, 2) at least one pedal pivotably connected to the base, and 3) a resistance mechanism which is configured to resist the rotation of the pedal with respect to a neutral position in at least two opposite directions. Furthermore, for portability, devices in accordance with the present disclosure are adjustable to at least two configurations: 1) an open, in use configuration, wherein the pedal is spaced away from the base to enable the pedal to rotate relative to the base, the pedal being disposed in the neutral position to receive a foot of a user, and 2) a closed configuration, wherein the pedal is adjacent to, collapsed against, or otherwise positioned near the base to minimize a space between the pedal and the base, and thereby the size of the device. The closed configuration does not permit use of the device but is configured to facilitate storage and/or transport of the device.

FIGS. 1-7 illustrate an exemplary exercise device 100, in accordance with an exemplary embodiment of the present disclosure, in an open, in use configuration. FIGS. 8-12 show the exercise device 100 in a closed configuration. As shown in FIGS. 1-12, the exercise device 100 includes a base 102, a pedal 101, and a resistance mechanism 103, with a set of four resistance mechanisms 103 being shown in the embodiment of FIGS. 1-12. As shown, the pedal 101 includes a toe end portion 104 and a heel end portion 105, and the pedal 101 is pivotably connected to the base 102 substantially midway between the toe end portion 104 and

the heel end portion 105 of pedal 101, as will be described in further detail below. As illustrated best perhaps in FIGS. 6 and 7, the base 102 provides a bottom surface 140 configured to support the device 100 against a support surface (e.g., the floor, ground, or a vertical support board 160) and configured to resist movement of device 100 relative to the support surface 160 while a user 123 is using the device 100. The pedal 101 provides a foot surface 150 configured to receive and support a foot 121 of the user 123 while the user 123 is using the device 100, as will be described in more detail below.

The pedal 101 may be formed from any material suitable for receiving and supporting the foot of a user in accordance with the present disclosure. In various exemplary embodiments, the pedal 101 may, for example, comprise a molded plastic material, such as, for example, a molded polypropylene material. Those of ordinary skill in the art will understand, however, that the pedal 101 may be made of various plastic materials, as well as various other materials, including, for example, wood and/or metal materials, as described further below. Suitable materials can include, for example, materials that are relatively light to facilitate carrying, packing, and transporting the device 100, yet durable and able to withstand repetitive use/motion.

As illustrated in FIGS. 1-12, the pedal 101 can be shaped to receive a user's foot, for example, the foot 121 of the user 123 (see FIGS. 6 and 7). In one exemplary embodiment, for example, the pedal 101 comprises a substantially flat, rectangular body 107 configured to receive the foot 121 of the user 123. In other exemplary embodiments, as illustrated in the embodiments of FIGS. 22-27, the pedal may comprise a more contoured shape that loosely resembles the shape of a foot. The pedal 101 can be sized to accommodate a range of foot and/or shoe sizes. In various exemplary embodiments of the present disclosure, for example, the pedal 101 can have a length LP (see FIG. 3) ranging from about 8 inches to about 15 inches, for example from about 9 inches to about 10 inches, and a width WP (see FIG. 4) ranging from about 2 inches to about 7 inches, for example, about 4 inches to about 5 inches.

As discussed above, the pedal 101 includes a toe end portion 104, a heel end portion 105, and a foot surface 150 extending between the toe end portion 104 and the heel end portion 105. The foot surface 150 may include, for example, various ridges, treads (see, e.g., foot surface 550 of portable exercise device 500 of FIGS. 18-21), coatings, applied surfaces (e.g., grip tape), laser markings, and/or other mechanisms to increase user comfort and/or to increase friction on the foot surface 150 with which the foot comes into contact, for example, to massage the user's foot and/or prevent the foot from slipping on the foot surface 150. Massage of the user's foot, via the foot surface 150 and any elements, coatings, or surfaces applied thereto, will apply pressure to the sole of the foot during the exercise, i.e., plantar pressure, which also contributes to movement of fluid through the body tissue and to an increase in circulation of bodily fluids.

In various embodiments, the foot surface 150 may include a removable pad upon which the foot may rest for comfort and/or additional support. Additionally or alternatively, the pad may be made from a soft, form fitting material, such as, for example, a shape memory polymer, which may conform to the feet of different users, as would be understood by those of ordinary skill in the art. In various additional embodiments, to simplify the device 100, grip tape and/or laser markings may be applied directly to the foot surface 150.

The pedal **101**, and the foot surface **150** of the pedal **101**, may have various sizes (i.e., dimensions), shapes, configurations and/or features without departing from the scope of the present disclosure. In various embodiments, for example, a foot guide can be placed on the foot surface **150** to assist in the proper placement of a user's foot on the pedal **101**. The foot guide may include, for example, a movable guide and/or a printed outline that is representative of several general foot size categories. In various further embodiments, the pedal may also be extensible to accommodate various foot/shoe sizes. For example, the pedal may be extensible such that both ends of the pedal are configured to move away from a center of the pedal a corresponding distance, to maintain a central position of the pivot axis and maintain stability of the device.

The base **102** may be formed from any material and/or combination of materials suitable for mounting the pedal **101** and stably supporting the device **100** relative to the support surface **160** while the user is using the device **100** in accordance with the present disclosure. In various exemplary embodiments, the base **102** may, for example, comprise a molded plastic material, such as, for example, a molded polypropylene material. Those of ordinary skill in the art will understand, however, that the base **102** may be made of various plastic materials, as well as various other materials, including, for example, wood and/or metal materials, as described further below. Suitable materials can include, for example, materials that are relatively light to facilitate carrying, packing, and transporting the device **100**, yet durable and able to withstand repetitive use.

As shown in FIGS. 1-12, in one exemplary embodiment of the present disclosure, the base **102** comprises a substantially flat, rectangular body **107** provided with a bottom surface **140** that is configured to rest against a support surface **160**, while the user **123** is using the device **100** (see FIGS. 6 and 7). The base **102** is appropriately sized and/or configured to stably support the pedal **101** (e.g., against the support surface **160**), when the exercise device **100** is in use. The body **106** of the pedal **101** and the body **107** of the base **102** have similar dimensions such that, when the device **100** is in the open configuration, and the pedal **101** is positioned to receive the foot **121** of the user **123** (see FIGS. 6 and 7), the pedal **101** is substantially parallel to the base **102** and respective corners of the bodies **106** and **107** are substantially in alignment with each other. Thus, in various exemplary embodiments, like the pedal **101**, the base **102** can have a length LB (see FIG. 3) ranging from about 8 inches to about 15 inches, for example from about 9 inches to about 10 inches, and a width WB (see FIG. 4) ranging from about 2 inches to about 7 inches, for example, about 4 inches to about 5 inches.

With reference to the device **500** of FIGS. 18-21, and as illustrated in FIGS. 43A-43B, in various other exemplary embodiments, the device **500** may include rectangular bodies **507a** (i.e., a first body or platform) and **507b** (i.e., a second body or platform) that may each function as both a pedal and a base. In such embodiments, as will be described in more detail below, the device **500** may have two open, in-use configurations: (1) a first open, in-use configuration in which the rectangular body **507a** functions as a pedal **501** and the rectangular body **507b** functions as a base **502** to support the device **500** against a support surface **160** (see FIGS. 43A and 43B); and (2) a second open, in use configuration in which the rectangular body **507b** functions as the pedal **501** and the rectangular body **507a** functions as the base **502** to support the device against the support surface **160** (see FIGS. 44A and 44B). In this manner, the device **500**

may be flipped over to change between the first and second open, in-use configurations. In such a configuration, as shown, for example, in FIGS. 43A-44B, each of the rectangular bodies **507a** and **507b** may include a respective surface **550** that is suitable both to support a foot of the user and provide traction against a support surface (i.e. such that the rectangular body does not slide on the support surface during use).

The base **102** may take on a variety of sizes, shapes, configurations and/or features without departing from the scope of the present disclosure. As illustrated in FIGS. 1-21, in some embodiments, for example, the base is solid, while in other embodiments, the base has cutouts (see, e.g., FIGS. 22-27) configured to reduce the weight of the base. Furthermore, in some embodiments, the bottom surface **140** of the base **102** may include various ridges, treads, coatings, applied surfaces, and/or other mechanisms to increase friction between the bottom surface **140** and the support surface **160** upon which the base **102** rests to prevent slippage of the base **102** on the support surface **160**. In other embodiments, the base **102** may be configured to be secured to the support surface **160**, via, for example, a bolt, screw, hook and loop material, and/or clamp. And, in further embodiments, as will be described in more detail below, the base may include a pair of collapsible supports that are connected to the pedal via aligned hinges, such that when the device is in the open configuration the supports form a triangular body (e.g., an A-frame or tent) that supports the pedal. In such an embodiment, a bottom surface of each support may include a mechanism to increase friction between the bottom surface of the support and the support surface. For example, as illustrated in the embodiments of FIGS. 52-58, the feet of each support **1810a**, **1910a** and **1810b**, **1910b** may include rubber booties **1850**, **1950** to increase friction between the feet and the support surface. In various further embodiments, the feet of each support **1810a**, **1910a** and **1810b**, **1910b** may be increased in size, have a different shape (e.g., to provide a different contact angle with the support surface), include various types and/or configurations of non-slip grips on a bottom surface thereof (e.g., include various ridges or other irregular surfaces integral with the feet or applied to a bottom surface thereof) to increase friction between the bottom surface of the support and the support surface.

In accordance with various embodiments, for example, to accommodate users in various positions, the device **100** may be used in both a sitting position (see FIG. 6) and a supine position (see FIG. 7). For example, as will be understood by those of ordinary skill in the art, the positioning of the device **100** can be adjusted such that the foot support portion **101** is disposed in a first position wherein the pedal **101** is in a neutral position N to receive a foot **121** of a user **123** in a sitting position (see FIG. 6) and a second position wherein the pedal **101** is in the neutral position N to receive a foot **121** of a user **123** in a supine position (see FIG. 7). In one example, to better support use in the supine position, the bottom surface **140** of the base **102** may be secured to a vertical support surface **160**, such as, for example, a backboard **160** of a bed surface **170**, as illustrated in FIG. 7.

As illustrated in FIGS. 6 and 7, in such embodiments (e.g., wherein the device **100** is secured to the support surface **160**), the device **100** may further comprise at least one strap **130** affixed to the pedal **101**, two straps **130** (i.e., a toe strap and a heel strap) being shown in the embodiment of FIGS. 6 and 7. The straps **130** may, for example, be configured to releasably secure the foot **121** of the user **123** to the pedal **101**. The straps **130** can be adjustable to permit loosening and tightening of the straps **130** around a user's

foot. By way of example only, the straps **130** may comprise hook and loop fasteners, such as, for example, Velcro®. Those of ordinary skill in the art will further understand that the straps **130** may comprise any type and/or configuration or mechanism to releasably secure a foot of the user to the pedal **101**, including for example, snaps, buttons, ties, buckles, elastic bands and/or any combination thereof. As will also be understood by those of ordinary skill in the art, the presence of a strap or other securing means is optional and is not necessary for use of the device. In some embodiments, for the device to be functional while secured to a user's foot, the base of the device must be secured to the floor, ground, or other stable surface. Thus, in some embodiments and in certain environments, operation of the device without a securing means may be preferred.

In accordance with exemplary embodiments of the present disclosure, the pedal **101** is pivotably connected to the base **102** via at least one hinge. As illustrated best perhaps in the open configuration of FIGS. 1-7, in one exemplary embodiment, the pedal **101** is pivotably mounted to the base **102** via a double-hinged support. For example, as shown in FIGS. 1-7, a support **110** is positioned between a first hinge **109** and a second hinge **111**, wherein the first hinge **109** is connected to the pedal **101** and the second hinge **111** is connected to the base **102**. As shown, the support **110** may be connected to the pedal **101**, via the hinge **109**, substantially midway between the toe end portion **104** and the heel end portion **105** of the body **106** of pedal **101**. The support **110** may also be mounted to the base **102**, via the hinge **111**, substantially midway between corresponding end portions of the body **107** of base **102**. In this manner, the support **110** is configured to rotate, via the hinges **109** and **111**, between an upright position (see FIGS. 1-7) and a collapsed position (see FIGS. 8-12), as will be explained further below. When the support **110** is positioned in the upright position, as illustrated in FIGS. 1-7, the support **110** extends between and substantially perpendicular to the parallel bodies **106** and **107** of the pedal **101** and the base **102**, respectively, thereby creating a space **S** therebetween (see FIG. 3). In such a configuration, the pedal **101** can pivot, via the hinge **109**, toward and away from the base **102**, and can have a neutral position **N** relative to a pivot axis **P** (see FIG. 14).

In accordance with additional exemplary embodiments, such as, for example, the dual-sided base support/pedal embodiment of FIGS. 18-21 and 43A-44B, the rectangular body **507a** (i.e., a first body or platform, which may function as either the pedal **501** or the base **502**) is pivotably connected to the rectangular body **507b** (i.e., a second body or platform, which can also function as either the pedal **501** or the base **502**) via at least two hinges. Similar to the embodiment of FIGS. 1-12, for example, in one exemplary embodiment, the rectangular body **507a** is pivotably mounted to the rectangular body **507b** via a double-hinged support. For example, as shown in FIGS. 18-21 and 43A-44B, a support **510** is positioned between a first hinge **509** and a second hinge **511**, wherein the first hinge **509** is connected to the rectangular body **507a** and the second hinge **511** is connected to the rectangular body **507b**. As shown, the support **510** may be connected to the rectangular body **507a**, via the hinge **509**, substantially midway between corresponding end portions of the rectangular body **507a**. The support **510** may also be mounted to the rectangular body **507b**, via the hinge **511**, substantially midway between corresponding end portions of the rectangular body **507b**. In this manner, the support **510** is configured to rotate, via the hinges **509** and **511**, between an upright position (see FIGS. 18-20) and a collapsed position (see FIG. 21). When the

support **510** is positioned in the upright position, as illustrated in FIGS. 18-21, the support **510** extends between and substantially perpendicular to the parallel rectangular bodies **507a** and **507b**, thereby creating a space therebetween. Thus, similar to the embodiment of FIGS. 1-12, in the first open, in-use configuration, the rectangular body **507a**, acting as the pedal **501** can pivot, via the hinge **509**, toward and away from the rectangular body **507b**, acting as the base **502** (see FIGS. 43A and 43B), and can have a first neutral position N_1 relative to a pivot axis **P**. And, in the second open in-use configuration, the rectangular body **507b**, acting at the pedal **501** can pivot, via the hinge **509**, toward and away from the rectangular body **507a**, acting as the base **502** (see FIGS. 44A and 44B), and can have a second neutral position N_2 relative to the pivot axis **P**.

As used herein, the term "neutral position" refers to a pedal starting position and a position of the pedal without external forces acting thereon to pivot the pedal about the pivot axis **P** (e.g., about the hinge **109**, **509**). Thus, when a pedal is in the "neutral position," the foot of a user, which is received by the pedal, is in a relaxed, un-flexed position (i.e., the user's foot is neither extended or flexed). In the exemplary embodiment of FIGS. 1-7, in the "neutral position", the pedal **101** is substantially parallel to the base **102**. With reference to FIGS. 13A, 13B, and 14, the pedal **101** is configured to rotate about the pivot axis **P** in a first direction away from the neutral position **N** and toward the base **102** and in a second direction away from the neutral position **N** and toward the base **102**, wherein the second direction is opposite the first direction. For example, the pedal **101** is configured to undergo a rocking type motion in which the pedal **101** rotates about the pivot axis **P** in a first direction **F** away from the neutral position **N** (see FIG. 13A) in which the toe end portion **104** moves toward the base **102** (and the heel end portion **105** moves away from the base **102**) and in a second direction **E** (see FIG. 13B) away from the neutral position **N** in which the heel end portion **105** moves toward the base **102** (and the toe end portion **104** moves away from the base **102**). In this manner, rotation is around the axis **P** provided by the hinge **109** on the device **100**, and, as illustrated in FIG. 14, the user's ankle **141** must pivot around this axis in an arc **C**. Consequently, the user's leg **122** must also move, in both an arc **B** and an arc **C**, to accommodate the rotation of the ankle **141** about the pivot **P**. For example, when the user **123** performs a plantarflexion motion, the ankle **141** rises, so the leg **122** must also rise. Similarly, when the user **123** performs a dorsiflexion motion, the ankle **141** lowers, so the leg **122** must also move lower.

Similar to the embodiment of FIGS. 1-7, in the exemplary embodiment of FIGS. 18-21, in the "neutral position", when in the first, open in-use configuration, the rectangular body **507a**, acting as the pedal **501**, is substantially parallel to the rectangular body **507b**, acting as the base **502**. With reference to FIGS. 43A and 43B, the rectangular body **507a** is configured to rotate about the pivot axis **P** in a first direction away from the neutral position **N** and toward the rectangular body **507b** and in a second direction away from the neutral position **N** and toward the rectangular body **507b**, wherein the second direction is opposite the first direction. Thus, in such a configuration, similar to the embodiment of FIGS. 1-7, the rectangular body **507a** is configured to undergo a first type of motion, a rocking type of motion in which the rectangular body **507a** rotates about the pivot axis **P**, while the support **510** is held in a fixed position. In other words, like the embodiment of FIGS. 1-7, the pivot axis **P** is directly adjacent to a foot of a user, such that the rectangular body **507a** by itself rotates about the pivot axis **P**, in a first

direction F away from the neutral position N (see FIG. 43A) in which a toe end portion moves toward the rectangular body 507b (and the heel end portion moves away from the rectangular body 507b) and in a second direction E (see FIG. 43B) away from the neutral position N in which the heel end portion moves toward the rectangular body 507b (and the toe end portion moves away from the rectangular body 507b). In this manner, while in the first, in-use configuration, the rectangular body 507a moves in a pivot, with rotation around the pivot axis P provided by the hinge 509 (i.e., the active hinge is located at the top of the support 510 and adjacent the foot 121), and, as illustrated in FIG. 14, the user's ankle 141 also must pivot around this axis in an arc C. Thus, while in the first, in-use configuration, the movement of the rectangular body 507a subjects the foot 121 of the user 123 to a first motion, which comprises pivoting the foot 121 about the ankle 122, while moving the ankle 141 in the arc C.

And, when the device 500 is flipped over and in the second, open in-use configuration, in the "neutral position", the rectangular body 507b, acting as the pedal 501 is substantially parallel to the rectangular body 507a, acting as the base 502. With reference to FIGS. 44A and 44B, the rectangular body 507b is configured to rotate about the pivot axis P, via the support 510, in a first direction away from the neutral position N and toward the rectangular body 507a and in a second direction away from the neutral position N and toward the rectangular body 507a, wherein the second direction is opposite the first direction. Thus, in such a configuration, the rectangular body 507b is configured to undergo a second type of motion, a combination motion in which the rectangular body 507b travels forward and aft while also rotating about the pivot axis P (i.e., via its attachment to the support 510). In other words, since the support 510 is also allowed to rotate in the second, open in-use configuration (i.e., relative to the base 502), the rectangular body 507b moves in a different motion with relation to the pivot axis P in comparison to the motion of the rectangular body 507a when the device 500 is in the first, open in-use configuration (i.e., when the support 510 is held fixed relative to the base 502). Indeed, in this configuration, the pivot axis P is lowered (i.e., relative to the first, open in-use configuration) and is spaced away from a foot of a user such that the support 510 rotates about the pivot axis P, and the rectangular body 507b (which is connected to the support 510 at the hinge 511) moves in a first direction F away from the neutral position N (see FIG. 44A) in which a toe end portion moves toward the rectangular body 507a (and the heel end portion moves away from the rectangular body 507a) and in a second direction E (see FIG. 44B) away from the neutral position N in which the heel end portion moves toward the rectangular body 507a (and the toe end portion moves away from the rectangular body 507a). In this manner, the rectangular body 507b moves in a forward and aft motion, with rotation around the pivot axis P provided by the hinge 509 (i.e., the active hinge is located at the bottom of the support 510 and spaced away from the foot 121). Thus, while in the second, in-use configuration, the movement of the rectangular body 507b subjects the foot 121 of the user 123 to a second motion, which comprises pivoting the foot 121 about the ankle 122, while also subjecting the ankle 122 to a forward and aft rocking motion.

The support 110 extending between the pedal 101 and the base 102 has a height h. When the device 100 is in the open, in use configuration, the pedal 101 and the base 102 are spaced apart from one another by the height h of the support 110. This space S has a height H_{S1} when the device 100 is

in the open configuration (see FIG. 3). The respective heights of the support 110 and the space S are configured to allow sufficient rotation of the pedal 101 in the first direction F about the pivot axis P (see FIG. 14) to subject a foot 121 of a user 123 to full flexion and to allow sufficient rotation of the pedal 101 in the second direction E about the pivot axis P (see FIG. 14) to subject the foot 121 of the user 123 to full extension. In various embodiments, for example, the space S may have a height H_{S1} that is sufficient for the length of the pedal 101 to clear the base 102 when moved through 75 degrees of plantar flexion and 60 degrees of dorsiflexion. Those of ordinary skill in the art will understand that, to support the pedal 101 while also achieving the goal of full ankle flexion/extension, the support 110 may employ various pivoting mechanisms, and have various shapes, configurations and/or sizes (i.e., dimensions), including various heights h, which create various spaces S (i.e., having various heights H_{S1}) between the pedal 101 and the base 102, without departing from the scope of the present disclosure.

The resistance mechanism 103 is configured to exert a force on the pedal 101 about the pivot axis P in a direction opposite to a respective direction of rotation of the pedal 101 about the pivot axis P. In one exemplary embodiment, the resistance mechanism 103 comprises a plurality of elastomeric bands 103, each of the bands 103 extending between and connected to the pedal 101 and the base 102. For example, as illustrated in FIGS. 1-12, an elastomeric band 103 extends between each pair of aligned corners of the bodies 106 and 107 of the pedal 101 and the base 102. During rotation of the pedal 101, the elastomeric bands 103 exert a force on the pedal 101 about the pivot axis P in a direction opposite to the respective direction of rotation of the pedal 101 about the pivot axis P. For example, when a foot presses down on the toe end portion 104 or the heel end portion 105 of the pedal 101, the elastomeric bands 103 on the opposite side of the device 100 (i.e., opposite to the pressing action) extend, thereby exerting a force against the movement of the pedal 101. In other words, when a foot (e.g., toes of the foot) presses down on the toe end portion 104, thereby moving the toe end portion 104 of the pedal 101 toward the base 102, the elastomeric bands 103 connected to the heel end portion 105 are extended as the heel end portion 105 moves away from the base 102, thereby exerting a force that resists the movement of the heel end portion 105 away from the base and the toe end portion 104 toward the base. Likewise, when a foot (e.g., a heel of the foot) presses down on the heel end portion 105, thereby moving the heel end portion 105 of the pedal 101 toward the base 102, the elastomeric bands 103 connected to the toe end portion 104 are extended as the toe end portion 104 moves away from the base 102, thereby exerting a force that resists the movement of the toe end portion 104 away from the base and the heel end portion 105 toward the base.

Accordingly, in various exemplary embodiments of the present disclosure, the force exerted by the elastomeric bands 103 may provide passive resistance to rotational movement of the pedal 101 in both directions (i.e., F and E of FIG. 14) about the pivot axis P. And, in various additional embodiments, an amount of the force may vary with a degree of rotation 8 (see FIG. 14) of the pedal 101 about the pivot axis P, for example, the amount of force may increase with the degree of rotation 8 of the pedal 101 about the pivot axis P.

Furthermore, to change the amount of force or resistance exerted by the elastomeric bands 103, various additional embodiments of the present disclosure contemplate, for example, providing elastomeric bands 103 that are remov-

able and/or reconfigurable, such that additional elastomeric bands **103** may be added to the device **100**, in addition to and/or in exchange for existing elastomeric bands **103**. In this manner, a user of the device **100** may increase and/or decrease the amount of force that is exerted by the elastomeric bands, to, for example, accommodate a user as strength increases or to otherwise scale up and/or down an exercise routine.

In accordance with various embodiments, for example, the pedal **101** of the exercise device **100** may include multiple catches for each elastomeric band **103** (e.g., each respective corner of the pedal **101** may include a set of multiple catches), such that a user may reposition each elastomeric band **103** within the set of multiple catches to increase/decrease the amount of force exerted by the elastomeric band **103** on the pedal **101**. As used herein the term "catch" or "catches" generally refers to a feature on the device that may removably retain an elastomeric band. Although in various embodiments of the present disclosure, as illustrated in the accompanying figures, such catches may include recesses within the pedal and/or base of the device, the term catch(es) as used herein is intended to include all types and configurations of indents, recesses, clips, slots, ties, snaps, buttons, etc. that may serve to removably retain an elastomeric band in different positions on the pedal and/or base.

In various embodiments, for example, as illustrated in the embodiment of FIGS. **49-51**, an exercise device **1700** may include a pedal **1701** that includes multiple sets **1740** of catches **1745**. As illustrated best perhaps in FIG. **51**, in one exemplary embodiment of the device **1700**, each set **1740** may include three catches **1745** (e.g., catches **1745a**, **1745b**, and **1745c**) that are each configured to retain a respective elastomeric band **1703**. As illustrated in FIG. **51**, each elastomeric band **1703** may, for example, include a knob **1715** at an end of the band **1703**, which is configured to be retained within each catch **1745** (i.e., of a respective set **1740** of catches **1745**). In this manner, a user may increase/decrease the amount of force exerted by each elastomeric band **1703** by reconfiguring the positioning of the elastomeric bands **1703** within the catches **1745** to increase/decrease a length **L** (see FIG. **49**) of the elastomeric band **1703** extending between the pedal **1701** and the base **1702**. For example, with reference to FIG. **51** again, to increase the force exerted by a respective elastomeric band **1703** (and decrease the length **L**), the elastomeric band **1703** can be moved from a first position within the catch **1745a** to a second position within the catch **1745b**. And, to further increase the force exerted by the elastomeric band **1703** (and further decrease the length **L**), the elastomeric band **1703** can be moved from the second position within the catch **1745b** to a third position within the catch **1745c**. Conversely, to then decrease the force exerted by the elastomeric band **1703** (and increase the length **L**), the elastomeric band **1703** can be moved back between the catches **1745c** and **1745a** (i.e., between the third and first positions). As illustrated in FIG. **49**, for example, in one exemplary combination of elastomeric bands **1703**, the bands **1703** on a first end **1730** (e.g., the toe end) of the pedal **1701** are positioned within catches **1745c** (in the third position), while the bands **1703** on a second end **1735** (e.g., the heel end) of the pedal **1701** are positioned within catches **1745b** (in the second position). In this manner, a length **L₁** of the elastomeric bands **1703** on the first end **1730** (i.e., the length **L₁** of the portion of the bands **1703** extending between the pedal **1701** and the base **1702**) is shorter than a length **L₂** of the elastomeric bands **1703** on the second end **1735** (i.e., the length **L₂** of the

portion of the bands **1703** extending between the pedal **1701** and the base **1702**). In such a configuration, the device **1700** will provide more resistance against the rotation of the first end **1730** of the pedal **1701** (e.g., against plantar flexion motion) than against the rotation of the second end **1735** of the pedal **1701** (e.g., against dorsiflexion motion).

Thus, as will be understood by those of ordinary skill in the art, a user can reconfigure the elastomeric bands **1703** many different ways (i.e., many different combinations) to provide various different levels of resistance based, for example, on the user's age and fitness, a given need, and/or the proposed application of the device. In other words, the exercise device **1700** may be readily adapted to a specific user and application. Exercise devices in accordance with the present disclosure further contemplate including catches in both the pedal and base portions of the device (e.g., when the device has a flippable configuration as described above with reference to FIGS. **18-21**), such that the elastomeric bands may be repositioned within each of the pedal and base, thereby providing even more combinations of resistance.

Various embodiments of the present disclosure also contemplate that additional sets of elastomeric bands (e.g., of different elasticity/resistance) can be separately purchased or sold in combination with the device, such that the bands can be switched out and/or replaced with different bands (e.g., bands made of stronger or different materials, bands having greater or less thickness, bands having more or less elasticity, etc.) as needed during a given exercise application. For ease of use, such bands can, for example, be colored coded based on their weight/elasticity (i.e., the amount of resistance that they provide). Various additional embodiments further contemplate that the disclosed exercise devices can be sold in a kit with different sets of elastomeric bands (e.g., different sets of color-coded elastomeric bands). As illustrated in FIG. **63**, for example, a kit **2100** may include a device **1800**, a sleeve **1200** (as described further below) for insertion/storage of the device **1800**, and multiple sets **1853** of elastomeric bands **1803**. Those of ordinary skill in the art will understand that the kit **2100** illustrated in FIG. **63** is exemplary only and that various types and/or configurations of kits including various types of storage devices (e.g., including various types of sleeves); various types of exercise devices; and various types/numbers of resistance mechanisms, including various sets of elastomeric bands, are contemplated without departing from the scope of the present disclosure and claims.

Those of ordinary skill in the art will further understand that resistance mechanisms in accordance with the present disclosure may comprise various types, numbers, configurations, and/or combinations of elements that may exert a force on the pedal **101** about the pivot axis **P** in a direction opposite to the respective direction of rotation of the pedal **101** and are not limited in any way to elastomeric bands, or to the particular exemplary configuration of elastomeric bands **103** of the embodiment illustrated in FIGS. **1-12**. Examples of resistance mechanisms other than elastomeric bands that can be used, or that can be used in combination with elastomeric bands, for example, at each respective end portion of the pedal **101**, include but are not limited to, for example, springs (see, e.g., springs **203** in portable exercise device **200** of FIG. **15**), inflatable devices (see, e.g., inflatable bags **303** in portable exercise device **300** of FIG. **16**), bellows (see, e.g., bellows **403** in portable exercise device **400** of FIG. **17**), and/or foams.

When such non-elastomeric resistance mechanisms are utilized (e.g., springs **203**, inflatable bags **303**, and/or bel-

lows 403), the resistance mechanisms on the same side of the device 100 as the pressing action may assist in returning the pedal 101 to the neutral position. In other words, when the toe end portion 104 of the pedal 101 moves toward the base 102, the non-elastomeric resistance mechanisms connected to the toe end portion 104 may assist in returning the pedal 101 to the neutral position N; and when the heel end portion 105 of the pedal moves toward the base 102, the non-elastomeric resistance mechanisms connected to the heel end portion 105 may assist in returning the pedal 101 to the neutral position N. In various exemplary embodiments, the amount of assist respectively provided by the non-elastomeric resistance mechanisms on the pedal 101 is proportional to the amount by which the pedal 101 is rotated about the pivot axis P and away from the neutral position N.

Various additional exemplary embodiments further contemplate utilizing a resistance mechanism that is positioned at the pivot P, as disclosed, for example, in International Patent Application No. PCT/US2019/015031, entitled "Devices and Methods for Exercising an Ankle, foot, and/or Leg, and filed on Jan. 24, 2019, the entire contents of which are incorporated by reference herein. Such resistance mechanisms may include, for example, but are not limited to friction devices, torsion bars, spring devices (e.g., torsion springs/linear springs), compliant mechanisms, detent dials, adjustable clutch mechanisms, piezoelectric/nanomotion motors, pneumatic, and/or hydraulic devices, such as, for example, hydraulic cylinders (see below), viscous damping devices, and/or devices utilizing smart fluids, such as, for example, magnetorheological fluids or electrorheological fluids. Various exemplary embodiments of the present disclosure additionally contemplate a portable exercise device that includes a triple hinge that may, for example, also function as the support. In such embodiments, the triple hinge may also incorporate the resistance mechanism. And, as illustrated in FIG. 22, for example, various further exemplary embodiments contemplate a portable exercise device 600, which includes molded hinges 609 (not shown in the view of FIG. 22) and 611 that are integral with a collapsible support 610. The collapsible support 610 may, for example, be made from a molded plastic material with the hinges 609 and 611 and/or locking mechanisms molded into it. In such a configuration, the molded hinge 609 could also house an adjustable resistance mechanism, such as, for example, one of the resistance mechanisms disclosed in International Patent Application No. PCT/US2019/015031. The resistance mechanisms and the respective ranges of resistance for the resistance mechanisms disclosed in International Patent Application No. PCT/US2019/015031 are incorporated herein by reference.

As illustrated in FIGS. 52-58, various additional exemplary embodiments of the present disclosure contemplate a portable exercise device 1800, 1900 having two molded hinges 1809, 1909 and 1811, 1911 at are adjacent to one another along a pivot axis P (see FIGS. 53 and 56), and which are integral with the device 1800, 1900. The device 1800, 1900 may, for example, be made from an injected molded plastic material or 3D printed with the hinges 1809, 1909 and 1811, 1911 molded into it. As illustrated in FIGS. 52-57, the device 1800, 1900 includes a pedal 1801, 1901 and a base 1802, 1902. In the exemplary embodiments of FIGS. 52-58, similar to the embodiments of FIGS. 36-42 described below, however, each base 1802, 1902 comprises of a pair of collapsible supports 1810a, 1910a and 1810b, 1910b that are connected to the pedal 1801, 1901 via the aligned hinges 1809, 1909 and 1811, 1911. In this manner, when the device 1800, 1900 is in the open configuration

(see, e.g., FIGS. 52 and 57), the supports 1810a, 1910a and 1810b, 1910b of the base 1802, 1902 form a triangular body (e.g., an A-frame or tent) that elevates the pedal 1801, 1901 with respect to the support surface. In accordance with various embodiments, for example, to place the device 1800, 1900 in the open configuration, the supports 1810a, 1910a and 1810b and 1910b are rotated outward with respect to the pedal 1801, 1901 (i.e., via hinges 1809, 1909 and 1811, 1911) and are locked into place (i.e., to form the triangular body) via a brace 1815, 1915 that is configured to run between the supports 1810a, 1910a and 1810b and 1910b. In such a configuration, for example, the brace 1815, 1915 is pivotably connected to one of the supports (e.g., support 1810b, 1910b) and may include one or more slots, one slot 1816, 1916 being shown in the embodiments of FIGS. 52-58, which are configured to mate with a corresponding bar 1817, 1917 in the other one of the supports (e.g., support 1810a, 1910a) to lock the device 1800, 1900 in the open configuration.

Although only one slot 1816, 1916 is shown in the embodiments of FIGS. 52-58, the present disclosure contemplates using various numbers, shapes, and/or configurations of slots 1816, 1916 and corresponding bars 1817, 1917, as will be understood by those of ordinary skill in the art. As illustrated in the embodiment of FIGS. 59-62, for example, an exercise device 2000 contemplates using multiple slots (e.g., three slots 2016 being shown in the embodiment of FIGS. 59-62) in a brace 2015, such that a height H of a pedal 2001 of the device 2000 can be adjusted via movement of a bar 2017 (e.g., in one of supports 2010a and 2010b) between the slots 2016.

To place the device 1800, 1900 in the closed configuration (see, e.g., FIG. 54), a user may release the bar 1817, 1917 from the slot 1816, 1916 (e.g., by pushing/pulling an end portion 1830, 1930 of the brace 1815, 1915 toward the pedal 1801, 1901), such that the supports 1810a, 1910a and 1810b, 1910b of the base 1802, 1902 fold (via the hinges 1809, 1909 and 1811, 1911) flat against the pedal 1801, 1901. In this manner, to conserve space, the device 1800, 1900 is designed to have a low-profile, which is substantially flat, when the device 1800, 1900 is in the closed configuration. As illustrated, for example, in the embodiment of FIGS. 59-62 (which is shown as being substantially transparent for ease of illustration), both the supports 2010a and 2010b and the brace 2015 are configured such that the pedal 2001 lays completely flush against the supports 2010a and 2010b when the device 2000 is in the closed configuration.

In accordance with various exemplary embodiments, the molded hinges 1809, 1909 and 1811, 1911 may each house an adjustable resistance mechanism, such as, for example, one of the resistance mechanisms disclosed in International Patent Application No. PCT/US2019/015031, entitled "Devices and Methods for Exercising an Ankle, foot, and/or Leg, and filed on Jan. 24, 2019. As above, the resistance mechanisms and the respective ranges of resistance for the resistance mechanisms disclosed in International Patent Application No. PCT/US2019/015031 are incorporated herein by reference. The present disclosure additionally contemplates that various additional types and/or configurations of resistance mechanisms may be incorporated within the hinges 1809, 1909 and 1811, 1911 without departing from the scope of the present disclosure and claims.

The present disclosure also contemplates, for example, that a single resistance mechanism may be incorporated within and span between the two adjacent hinges along the pivot axis P. As illustrated in the embodiment of FIGS.

59-62, in one exemplary embodiment, a torsion element 2020, such as, for example, a torsion bar or torsion spring, may span between hinges 2009 and 2011 along a pivot axis P. The present disclosure further contemplates that various additional types and/or configurations of resistance mechanisms can be used in conjunction with or in place of such resistance mechanisms (which are incorporated into the molded hinges). As further illustrated in the embodiment of FIGS. 59-62, in the exercise device 2000, a set of resistance bands 2003 may be used in conjunction with, or in lieu of, the torsion element 2020 to further adjust/increase the amount of resistance provided by the device 2000.

And, similar to the embodiment of FIGS. 1-12, as illustrated in FIG. 58, in various further embodiments, the device 1800 may include a plurality of elastomeric bands 1803, a set of four elastomeric bands 1803 being shown in the embodiment of FIG. 58, with each of the bands 1803 extending between and connected to the pedal 1801 and the base 1802. As above, the elastomeric bands 1803 can be used in conjunction with, or in lieu of, resistance mechanisms incorporated into the molded hinges 1809 and 1811 to adjust the amount of resistance provided by the device 1800. For example, as above, the exercise device 1800 may include multiple catches for each elastomeric band 1803 (e.g., each respective corner of the pedal 1801 may include a set of multiple catches), such that a user may reposition each elastomeric band 1803 within the set of multiple catches to increase/decrease the amount of force exerted by the elastomeric band 1803 on the pedal 1801. Furthermore, also as above, with reference to FIG. 63, the device 1800 may be included within a kit 2100 that comes with multiple sets 1853 of elastomeric bands 1803 (e.g. of color-coded elastomeric bands).

For portability, the device 100 is adjustable between at least two configurations. As shown in FIGS. 1-7, the device 100 may be adjusted to an open configuration wherein the pedal 101 is disposed in the neutral position N to receive a foot 121 of a user 123. Alternatively, as shown in FIGS. 8-12, the device 100 may be adjusted to a closed configuration wherein the pedal 101 is collapsed against the base 102 to minimize the space S between the pedal 101 and the base 102, thereby minimizing the profile of the device 100 for ease of transport. Thus, as discussed above, the device 100 includes a collapsible support 110 that is configured to rotate, via hinges 109 and 111, between an upright position in which the support 110 is perpendicular to the parallel bodies 106, 107 of the pedal 101 and the base 102 (see FIGS. 1-7) and a collapsed position in which the support 110 is parallel to the parallel bodies 106, 107 of the pedal 101 and the base 102 (see FIGS. 8-12). In this manner, the device 100 may be transitioned between the open and closed configuration via moving the support 110 between the upright and collapsed position, for example, by raising and lowering the support 110 with respect to the base 102 via the hinges 109 and 111.

Those of ordinary skill in the art will understand that embodiments of the present disclosure contemplate various mechanisms, which include various configurations of features, for transitioning the device 100 between the open and closed configurations, and are not limited in any way to the collapsible support 110 of the embodiment illustrated in FIGS. 1-12. Furthermore, the collapsible support 110 may be used in combination with various mechanisms to increase the stability of the device 100, when the device is in the open configuration. In various embodiments, for example, as illustrated in the embodiment of FIGS. 18-21, the device

may further include a block that is secured to the base, against which the collapsible support may rest when in the open configuration.

In accordance with various embodiments of the present disclosure, the device 100 may include, for example, a closure mechanism 115 that is configured to transition the device 100 between the open and closed configurations. In various exemplary embodiments, the closure mechanism 115 includes a cord 116 and a clamp 117, such as, for example, a v-clamp 117. As illustrated in the embodiment of FIGS. 1-12, the clamp 117 is mounted to an end portion of the base 102, on a top surface 145 of the base 102. And, the cord 116 is configured to extend between the support 110 and the clamp 117. In various exemplary embodiments, the cord 116 is affixed to the support 110 at a location adjacent to the pedal 101, such as, for example, at a location of the hinge 109 connecting the support 110 to the pedal 101. As shown best perhaps in FIGS. 3-5, a first end of the cord 116 may be, for example, threaded through a hole 119 in the hinge 109/support 110 and knotted on the opposite side of the support 110, while a second end of the cord 116 is threaded through the clamp 117. In this manner, the support 110 may be raised and lowered with respect to the base 102 (i.e., transitioned between the upright and collapsed configurations) by respectively securing and releasing the cord 116 within the clamp 117. In other words, to raise the support 110 and maintain (lock) the support 110 in the upright configuration, the cord 116 may be pulled taut and secured within the clamp 117. And, to lower the support 110 the cord 116 may be released from the clamp 117, such that the cord 116 is slackened to allow the support 110 to collapse against the top surface 145 of the base 102 via the hinges 109 and 111.

Those of ordinary skill in the art will understand that devices in accordance with the present disclosure may comprise various types, numbers, configurations, and/or combinations of closure mechanisms to transition the device between the open configuration and the closed configuration and are not limited in any way to the cord and clamp mechanism of the embodiment illustrated in FIGS. 1-12. As illustrated in the embodiment of FIG. 22, for example, one embodiment of the present disclosure contemplates a device 600 that utilizes a plastic clamp 617 to lock the device 600 in the open configuration. The clamp 617 may include, for example, an upper jaw 618 that pivots with respect to a lower jaw 619, such that the upper jaw 618 may clamp down on a cord 616 that runs between the jaws 618 and 619. As illustrated in the embodiment of FIGS. 13A and 13B, for example, various additional embodiments of the present disclosure contemplate that the device 100 utilizes a cord 116 that interconnects directly with the base 102, such as, for example, with a notch 114 or other feature of the base 102. In various additional embodiments, the device may utilize a cord that has a ball at one end (see e.g., cord 516, having a ball 560, of portable exercise device 500 of FIGS. 18-21) to prevent the cord from sliding through the clamp. In various further exemplary embodiments, the device 100 may utilize a bar that is raised and lowered with respect to the support 110 to lock the support in the open configuration (e.g., similar to a kick stand as illustrated in the exemplary embodiment of FIGS. 34 and 35).

As illustrated in FIGS. 8-12, in the closed configuration of the device 100, the pedal 101 is collapsed against the base 102, reducing the space S between the pedal 101 and the base 102, such that the device 100 has a minimized profile. In this configuration, the support 110 is in a collapsed position in which the support 110 is parallel to the parallel

bodies **106**, **107** of the pedal **101** and the base **102**. In other words, in the closed configuration of the device **100**, the cord **116** of the closure mechanism **115** is slack such that the pedal **101** and support **110** can pivot, via the hinges **109** and **111**, to collapse and lay flat against the base **102**. Consequently, in this configuration, the elastomeric bands **103** are also substantially slack and collapsed with respect to the base **102**, as further illustrated in FIGS. 8-12.

In accordance with various exemplary embodiments, in the closed configuration of the device **100**, the space **S** between the pedal **101** and the base **102** is minimized such that a height H_{S2} of the space **S** is less than the height H_{S1} of the space **S** when the device **100** is in the open configuration. Consequently, in the closed configuration of the device **100**, an overall height of the device **100** is also reduced. In various embodiments, for example, an overall height H_1 of the device **100** in the open configuration (see FIG. 3) ranges from about 3 inches to about 5 inches, while an overall height H_2 (see FIG. 10) of the device in the closed configuration ranges from about 1 inches to about 3 inches. Those of ordinary skill in the art will understand, for example, that the devices in accordance with the present disclosure may come in various sizes, having various different overall heights H_2 , to accommodate users of various sizes, having various different heights and foot sizes.

To help keep the device in the closed configuration, various embodiments of the present disclosure may also include a restraint. One exemplary embodiment may include a tie mechanism, such as, for example, a band (see, e.g., band **580** of portable exercise device **500** of FIG. 21) that is tied around the device to secure the collapsed pedal to the base. Another exemplary embodiment may include a pair of components configured to fit together in a tight manner such as in a press-fit or snap fit manner (see, e.g., components **980** and **981** of portable exercise device **900** of FIGS. 25 and 26) and that lock together when the device is in the closed configuration to secure the collapsed pedal to the base (see FIG. 26). In the exemplary embodiment, the elements comprise projection **981** and hole **980** that fit together in a press-fit or snap-fit manner. However, as will be apparent to those of ordinary skill in the art, it is possible that other configurations of objects to be connected in a press-fit or snap-fit manner may be used. For example, nesting objects which fit together in a press-fit or snap-fit manner may be used. Another exemplary embodiment may include a strap, such as, for example, a Velcro® strap that is connected to the pedal and configured to attach, for example, to a loop material on a bottom surface of the base (see, e.g., strap **1080** and material **1081** of portable exercise device **1000** of FIGS. 28 and 29) when the pedal is collapsed against the base (see FIG. 29). Another exemplary embodiment may include a magnet on a top surface of the base (see, e.g., magnet **1181** of portable exercise device **1100** of FIGS. 30 and 31) that is configured to attach to a corresponding magnet on a bottom surface of the pedal (not shown in the view of FIG. 30) when the pedal is collapsed against the base (see FIG. 31). Those of ordinary skill in the art will understand that devices in accordance with the present disclosure may comprise various types, numbers, configurations, and/or combinations of restraint mechanisms to help keep the device in the closed configuration and are not limited in any way to the components illustrated in FIGS. 21, 25, 26, and 28-31. Those of ordinary skill in the art will further understand that devices in accordance with the present disclosure may be used in conjunction with various accessory devices, for example, in which to store the device when the device is locked in the closed configuration. As illustrated in FIG. 27, for example,

various embodiments of the present disclosure contemplate portable exercise devices that, when locked in the closed configuration, are stored within a sleeve, such as, for example, a cloth or neoprene sleeve (see, e.g., sleeve **1200** of FIG. 27). A storage sleeve may, for example, provide both function and aesthetics. The sleeve may (1) protect the device from damage, (2) contain dirt and other contaminants the device may pick up during use, (3) aid in the carrying of the device, and (4) provide an aesthetic means of transporting and storing the device.

Various additional embodiments of the present disclosure contemplate utilizing a single locking mechanism that functions to both (1) lock the device in the open configuration for use, and (2) lock the device in the closed configuration for storage. In one embodiment, such a locking mechanism may function, for example, similar to a conventional locking mechanism utilized by folding tables, in which the support includes a sliding arm that is spring-loaded on a pin. As will be understood by those of ordinary skill in the art, as the sliding arm gets pushed out (i.e., to open the device) and in (i.e., to close the device), the arm may slide back and forth along the pin (i.e., via a slot/track in the center of the arm). And, at either end of the track (i.e., when the device is fully open or fully closed), the arm pops out of the track and locks into place. To change the configuration of the device, the user then depresses the pin to unlock the device and move the pin back into the track. In accordance with various additional exemplary embodiments, as illustrated in FIGS. 34 and 35, an exercise device **1400** may include a similar locking mechanism comprising an arm **1417** that is configured to lock into place, in either an open configuration (see FIG. 34) or a closed configuration (see FIG. 35), for example, via notches **1418** in the base **1402** of the device **1400**. In this manner, the arm **1417** functions like a kick stand that may lock into place in either an open or closed configuration. In further exemplary embodiments, as illustrated in FIGS. 36-42 and described below, exercise devices **1500** and **1600** may each include a locking mechanism **1515**, **1615** comprising a strap (e.g., a soft goods strap) **1516**, **1616** that is used in conjunction with a hook (e.g., a G-hook) **1517**, **1617** to lock the device **1500**, **1600** into place, in either an open configuration (see FIGS. 36 and 40) or a closed configuration (see FIGS. 37-39 and FIGS. 41-42).

And, in still further exemplary embodiments, the locking mechanism may be built into one of the hinges. In one embodiment, for example, as illustrated in FIGS. 45-51, exercise device **1700** may include a self-locking, foldable hinge **1711**, which functions like another conventional locking mechanism utilized by folding tables. As illustrated best perhaps with respect to the enlarged views of FIGS. 46 and 47, the self-locking, foldable hinge **1711** includes a spring-loaded lever **1720** configured to move between a first notch **1721** and a second notch **1722**. For example, to lock the device **1700** into place in the open configuration (see FIGS. 45 and 46), the lever **1720** is moved (i.e., by a user **123**) into the first notch **1721**. And, to lock the device **1700** into place in the closed configuration, the lever **1720** is moved (i.e., by the user **123**) into the second notch **1722** (see FIG. 48).

As described above, those of ordinary skill in the art will understand that the disclosed portable exercise devices, including the pedal and support, may be made of various materials, including, for example, various light weight wood materials, such as, for example, plywood, medium-density fiberboard (MDF), birch wood, and balsam wood. As above, such materials may be relatively light to facilitate carrying, packing, and transporting the device, yet durable enough to withstand repetitive use/motion. FIGS. 23-31, 36-42, and

45-51 for example, illustrate several exemplary embodiments of portable exercises devices **700**, **800**, **900**, **1000**, **1100**, **1500**, **1600**, and **1700** made from a light weight wood material.

Similar to the portable exercise device **100** described above, each of the devices **700**, **800**, **900**, **1000**, **1100**, and **1700** includes a pedal **701**, **801**, **901**, **1001**, **1101**, **1701**; a base **702**, **802**, **902**, **1002**, **1102**, **1702**; and a collapsible support **710**, **810**, **910**, **1010**, **1110**, **1710** connecting the pedal **701**, **801**, **901**, **1001**, **1101**, **1701** to the base **702**, **802**, **902**, **1002**, **1102**, **1702** (e.g., via hinges); such that the pedal **701**, **801**, **901**, **1001**, **1101**, **1701** may be raised and lowered with respect to the base **702**, **802**, **902**, **1002**, **1102**, **1702**. As will be understood by those of ordinary skill in the art, each of these devices may also be configured to flip over (i.e., such that the device may undergo the second type of combination motion, in which the pedal travels forward and aft while also rotating about the pivot axis P) similar to the exercise device **500**. FIGS. 49-51, for example, illustrate an embodiment of the device **1700** in which the device **1700** is flipped over.

Also similar to the portable exercise device **100**, each of the devices **1500** and **1600** includes a pedal **1501**, **1601** and a base **1502**, **1602**. In the exemplary embodiments of FIGS. 36-42, however, each base **1502**, **1602** comprises of a pair of collapsible supports **1510a**, **1610a** and **1510b**, **1610b** that are connected to the pedal **1501**, **1601** via a hinge **1509**, **1609**. In this manner, when the device **1500**, **1600** is in the open configuration (see FIGS. 36 and 40), the supports **1510a**, **1610a** and **1510b**, **1610b** of the base **1502**, **1602** form a triangular body (e.g., an A-frame or tent) that elevates the pedal **1501**, **1601** with respect to the support surface. And, when the device **1500**, **1600** is in the closed configuration (see FIGS. 37-39 and FIGS. 41-42), the supports **1510a**, **1610a** and **1510b**, **1610b** of the base **1502**, **1602** fold (via the hinge **1509**, **1609**) flat against the pedal **1501**, **1601**.

To both simplify and reduce the weight of the devices **700**, **800**, **900**, **1000**, **1100**, **1500**, **1600**, **1700** in the present embodiments, these components are at least partly made from a wood material. In one embodiment, for example, the pedals **701**, **801**, **901**, **1001**, **1101**, **1701**, bases **702**, **802**, **902**, **1002**, **1102**, **1702**, and supports **710**, **810**, **910**, **1010**, **1110**, **1710** are each made of plywood, such as, for example, a $\frac{1}{4}$ inch to a $\frac{3}{8}$ inch plywood that is sanded and varnished to a smooth finish. In another embodiment, the pedal **1501** and the supports **1510a** and **1510b** are each made of MDF, with the pedal further including a birch top piece **1550**. In yet another embodiment, the pedal **1601** is made of MDF with a birch top piece **1650**, while the supports **1610a** and **1610b** are made of aluminum. In various embodiments, for example, the supports **1610a** and **1610b** include bent, hollow tubes. Furthermore, as illustrated in FIG. 38, in such embodiments, elastomeric bands **1503**, **1603** of the resistance mechanism may be passed through an MDF support **1547**, **1647** of the pedal **1501**, **1601**, which is covered by the birch top piece **1550**, **1650**, and connected to respective supports **1510a**, **1610a** and **1510b**, **1610b** (e.g., via holes **1513**, **1613** (see, e.g., FIGS. 36 and 40) in the supports **1510a**, **1610a** and **1510b**, **1610b**). Those of ordinary skill in the art will understand that the wood embodiments depicted in FIGS. 23-31 and 36-42 are exemplary only and that any combination of wood/non-wood materials may be used.

Those of ordinary skill in the art will further understand that various resistance mechanisms and locking mechanisms, as described above in FIGS. 1-22, may be used in conjunction with such wood devices. As illustrated in FIG. 23, for example, in one exemplary embodiment, similar to

the embodiment of FIG. 22, the device **700** utilizes a locking mechanism comprising a plastic clamp **717**. As illustrated in FIG. 33, in another exemplary embodiment, a device **1300** utilizes a locking mechanism comprising a plastic cleat **1317** that is embedded within a keyhole **1318** cut into a base **1302** of the device **1300**. As will be understood by those of ordinary skill in the art, in such embodiments, to lock the device **1300** in the open configuration, the pedal may be raised and a cord **1316** may be locked within teeth **1312** of the cleat **1317**. In other exemplary embodiments, similar to the embodiment of FIGS. 13A and 13B, the devices **800**, **900**, **1000**, **1100** respectively utilize a cord **816**, **916**, **1016**, **1116** that interconnects directly with the base **802**, **902**, **1002**, **1102** such as, for example, with holes **812**, **912**, **1012**, **1112** and **814**, **914**, **1014**, **1114** or other features of the base **802**, **902**, **1002**, **1102**. For example, the device **800**, **900**, **1000**, **1100** may have two differently sized holes **812**, **912**, **1012**, **1112** and **814**, **914**, **1014**, **1114** that are connected by a small channel **815** (not shown), **915** (see FIG. 26), **1015** (see FIG. 29), **1115** (see FIG. 31). The smaller of the two holes **812**, **912**, **1012**, **1112** is configured to retain a small knot **813**, **913**, **1013**, **1113** in the cord **816**, **916**, **1016**, **1116** to lock the device **800**, **900**, **1000**, **1100** in the open configuration (see FIGS. 24, 25, 28, and 30) and the larger of the two holes **814**, **914**, **1014**, **1114** is configured to let the knot **813**, **913**, **1013**, **1113** pass. In this manner, the device **800**, **900**, **1000**, **1100** may be closed by tugging the cord **816**, **916**, **1016**, **1116** through the channel **815**, **915**, **1015**, **1115** to move the cord from the small hole **812**, **912**, **1012**, **1112** to the large hole **814**, **914**, **1014**, **1114**. In still further exemplary embodiments, the devices **1500**, **1600** utilize a locking mechanism **1515**, **1615** that includes a strap (e.g., a soft goods strap) **1516**, **1616** (including two strap portions) and a hook (e.g., a G-hook) **1517**, **1617**. The strap **1515**, **1615** connects directly to each of the supports **1510a**, **1610a** and **1510b**, **1610b** and is adjusted (i.e., to lock the device **1500**, **1600** in either the open or closed configuration) via the hook **1517**, **1617**. In the embodiment of FIGS. 36-39, for example, a respective strap portion **1516a** and **1516b** is connected to each support **1510a** and **1510b** via a notch **1512** in the base of each support **1510a** and **1510b**. And, in the embodiment of FIGS. 40-42, a respective strap portion **1616a** and **1616b** is configured to wrap around the base of each support **1610a** and **1610b** (i.e., around an aluminum tube forming the base of each support **1610a** and **1610b**). Thus, as illustrated in FIGS. 36 and 40, when the device **1500**, **1600** is in the open configuration, the two strap portions **1516a**, **1616a** and **1516b**, **1616b** are connected via the hook **1517**, **1617** such that the strap **1516**, **1616** runs under the triangular body formed by the supports **1510a**, **1610a** and **1510b**, **1610b**. In such a configuration, a height of the device can also be adjusted by adjusting a length of the strap **1516**, **1616** running between the base portions **1510a**, **1610a** and **1510b**, **1610b** (e.g., the two strap portions **1516a**, **1616a** and **1516b**, **1616b** can be connected at different points via the hook **1517**, **1617** to adjust the length of the strap **1516**, **1616**). In other words, the pedal **1501**, **1601** can be raised by shortening the length of the strap **1516**, **1616** and the pedal **1501**, **1601** can be lowered by lengthening the strap **1516**, **1616**. And, as illustrated in FIGS. 37 and 41, when the device **1500**, **1600** is in the closed configuration, the two strap portions **1516a**, **1616a** and **1516b**, **1616b** are connected via the hook **1517**, **1617** such that the strap **1516**, **1616** runs over the birch top piece **1550**, **1650** to lock the device **1500**, **1600** in the closed configuration.

As above, for portability it is also advantageous for devices in accordance with the present disclosure (including

the wood devices) to have a low profile when in the closed configuration (i.e., to minimize the packing profile). Accordingly, as illustrated in the embodiments of FIGS. 25-31, various embodiments further contemplate utilizing components that lock together when the device is in the closed configuration. One embodiment, for example, contemplates utilizing a pair of components 980 and 981 that fit together in a tight manner (e.g., a press-fit or snap fit manner) when the device 900 is in the closed configuration. The components may, for example, include a rubber piece 981 on the support 910 that is configured to imbed within a hole 980 in the pedal 901 when the device 900 is in the closed configuration.

Another embodiment contemplates utilizing components 1080 and 1081 that stick together when the device 1000 is in the closed configuration. The components may, for example, include a "hook-type" fastener material 1080 on the pedal 1001 (e.g., a Velcro® strip) that is configured to attach to a "loop-type" fastener material 1081 on the support 1002 (e.g., on the bottom surface of the support 1002) when the device 1000 is in the closed configuration. Another embodiment contemplates utilizing components that connect magnetically when the device 1100 is in the closed configuration. The components may, for example, include a magnet 1181 on a top surface of the support 1102 that is configured to connect to a magnet (not shown) on a bottom surface of the pedal 1101 when the device 1100 is in the closed configuration.

As illustrated in the embodiments of FIGS. 36-42, various additional embodiments contemplate utilizing a pedal 1501, 1601 and base 1502, 1602 that are configured to lay flush when the device 1500, 1600 is in the closed configuration. In the embodiment of FIGS. 36-39, for example, to place the device 1500 into the closed configuration, the wood supports 1510a and 1510b may rotate (via the hinge 1509) up against the pedal 1501 (i.e., such that they lay flat against an underside of the support 1547 of the pedal 1501), and the elastomeric bands 1503 are configured to nest internally within the support 1547 of the pedal 1501 (not shown). Similarly, in the embodiment of FIGS. 40-42, to place the device 1600 into the closed configuration, the aluminum supports 1610a and 1610b may rotate (via the hinge 1609) up against the pedal 1601 (i.e., such that they frame the support 1647 and lay flat against an underside of the top piece 1650 of the pedal 1601); and the elastomeric bands 1603 are configured to nest within cutouts 1614 in an underside of the support 1647 of the pedal 1601 (see FIG. 42).

Such components and configurations may serve to minimize the packing profile of the device 900, 1000, 1100, 1500, 1600 while also helping to secure the pedal 901, 1001, 1101, 1501, 1601 to the base 902, 1002, 1102, 1502, 1602 during transport. Also, as above, to provide both protection and containment (e.g., of any dirt or contaminants that the device 900, 1000, 1100, 1501, 1601 may have picked up during use), the device 900, 1000, 1100, 1501, 1601 may also be inserted into a storage sleeve 1200 as illustrated, for example, in FIG. 27.

As above, those of ordinary skill in the art will understand that the portable exercise devices described above with reference to the wood embodiments of FIGS. 23-31 and 36-42 are exemplary only, and that portable exercise devices in accordance with the present disclosure may comprise various types, numbers, configurations, and/or combinations of the above described elements and features without departing from the scope of the present teachings and claims.

In accordance with various exemplary embodiments of the present disclosure, an exemplary method for exercising muscles in an ankle, foot, and/or leg of a user 123 using the exercise device 100, as illustrated in the embodiments of FIGS. 1-13B, will now be described with reference to FIGS. 1-14. For use, the exercise device 100 may be placed in an open configuration, as shown in FIGS. 1-7, 13A, and 13B. Alternatively, during travel or when otherwise storing and/or transporting the device 100, the exercise device 100 may be placed in a closed configuration, as shown in FIGS. 7-12. Consequently, exemplary methods for exercising in accordance with the present disclosure, contemplate that a configuration of the device 100 may be adjusted from a closed confirmation to an open configuration, wherein, as described above, in the closed configuration, the pedal 101 is collapsed against the base 102, and, in the open configuration, the pedal 101 is raised into an elevated position with respect to the base 102 to receive a foot 121 of a user 123.

The configuration of the device 100 may be adjusted from the closed configuration to the open configuration by lifting the pedal 101 off the base 102 and into a position substantially parallel to and aligned with the base 102, such that a space S is formed between the pedal 101 and the base 102. In various exemplary embodiments, the pedal 101 may be held in the open configuration position (neutral position) via the support 110, which is positioned between the pedal 101 and the base 102. As previously noted, the support 110 is connected to each of the pedal 101 and the base 102 via a respective hinge 109 and 111. The support 110 may, for example, be raised and lowered with respect to the base 102 (i.e., transitioned between an upright and collapsed configuration as described above) by respectively securing and releasing a cord 116 that is attached to the support 110. In other words, to raise the support 110 and maintain the support 110 in the upright configuration (and thereby raise the pedal 101 and maintain the device 100 in the open configuration), the cord 116 may be pulled taut and secured, for example, within a clamp 117. And, to lower the support 110 (and thereby lower the pedal 101 and place the device in the closed configuration) the cord 116 may be released from the clamp 117, such that the cord 116 is slackened to allow the support 110 to collapse against a top surface 145 of the base 102 via the hinges 109 and 111.

When in the open configuration, a foot 121 of the user 123, for example, a right foot 121 is set on the foot surface 150 of the pedal 101. Upon initial use of the exercise device 100, the pedal 101 may receive the user's 123 foot 121 in a neutral position N relative to a pivot axis P (see FIGS. 6 and 7). As shown for illustrative purposes in FIGS. 13A and 13B, using for example a right foot 121, the user 123 can rotate the pedal 101 in a first and second opposite directions, F and E respectively, about the pivot axis P against a resistive force Z exerted against the pedal 101 in a direction opposite to the rotating direction (i.e., opposite to the direction F or E). For example, the user 123 can rotate the pedal 101 in the first direction F about the pivot axis P to move a first end (e.g., the toe end portion 104) of the pedal 101 toward the base 102, while a force exerted (e.g., by a resistance mechanism 103) against a second end (e.g., the heel end portion 105) of the pedal 101 resists the pivoting motion. Likewise, the user 123 can rotate the pedal 101 in the second direction E about the pivot axis P to move the second end (e.g., the heel end portion 105) of the pedal 101 toward the base 102, while a force exerted (e.g., by the resistance mechanism 103) against the first end (e.g., the toe end portion 104) of the pedal 101 resists the pivoting motion. In this manner, rotating the pedal 101 in the first and second directions may cause a rocking

movement of the pedal **101** about the pivot axis P. Thus, as illustrated in FIG. **13A**, rotating the pedal **101** in the first direction F may comprise depressing a toe end portion **104** of the pedal **101** and, as shown in FIG. **13B**, rotating the pedal **101** in the second direction E may comprise depressing a heel end portion **105** the pedal **101**.

As explained above, in various exemplary embodiments, the amount of force exerted against the pedal **101** may vary with a degree of rotation **8** of the pedal **101** about the pivot axis P (see FIG. **14**), for example, the amount of force exerted against the pedal **101** may increase with the degree of rotation **8** of the pedal **101** about the pivot axis P. In this way, the further away from the neutral position the user **123** rotates the pedal **101**, the more force that is required by the user **123** to maintain the position of the pedal **101**.

Although not shown, similarly, the device may be used with a left leg/left foot of the user **123**. For example, in the same manner, the left foot may be set on the foot surface **150** of the pedal **101**. As above, the user **123** can then rotate the pedal **101** in first and second opposite directions F and E about the pivot axis P against a force exerted against the pedal **101** in a direction opposite to the rotating direction (i.e., opposite to the direction F or E).

Various exemplary embodiments of the present disclosure, therefore, contemplate rotating the pedal **101** in the first and/or second opposite directions F and E to subject the corresponding foot of a user to both plantar flexion motion (e.g., with reference to FIG. **13A**, movement of the toes of the foot **121** away from the shin, thereby contracting the calf muscle) and dorsiflexion motion (e.g., with reference to FIG. **13B**, movement of the toes of the foot **121** toward the shin, thereby stretching the left calf muscle). In this manner, using the exercise devices in accordance with various exemplary embodiments of the present disclosure can exercise both dorsiflexor and plantar flexor muscle groups, providing full flexion and extension of the ankle joint to increase blood circulation in the lower extremities of the body. In other words, such exercise devices may engage both calf muscle pump and venous foot pump to enhance the return of venous blood from the lower extremities to the heart.

In various exemplary embodiments of the present disclosure, for example, rotation of the pedal **101** in the direction F may subject the corresponding foot through up to about 75 degrees of plantar flexion (e.g., rotation ranging from about neutral to 75 degrees); and rotation of the pedal **101** in the direction E may subject the corresponding foot through up to about 60 degrees of dorsiflexion (e.g., rotation ranging from about neutral to -60 degrees).

To demonstrate the efficacy of the devices, a clinical pilot study was performed using 12 healthy, adult volunteers. In the study, each participant used a similar device to the above device **100** to exercise, while being monitored by ultrasound Doppler using a linear probe. The subjects were seated at a sufficient height to achieve bent knees (90 degrees of flexion), with their right foot engaged with the device. Each subject rested in the seated position until blood flow parameters stabilized, after which time resting blood flow measurements were conducted. Blood vessel diameter measurements were taken using the ultrasound Doppler as visualized on the screen and the diameter was observed to remain constant before and through the exercise. Each participant then commenced with 1 minute of exercise, performing maximum effort right lower limb plantar/dorsiflexion maneuvers at 35 cycles per minute, as indicated by a metronome (i.e., wherein one cycle was defined as going from maximum dorsiflexion to maximum plantar flexion and back to the starting position). Blood flow measurements

were then repeated immediately following completion of exercise, and then at 5 minutes, 10 minutes, and 15 minutes following completion of exercise. Post-exercise values for blood flow velocity and blood vessel diameter were then divided by pre-exercise values to calculate the respective ratios of each. The results of the clinical study are illustrated in FIG. **32**, which plots the average percentage increase in blood flow over time for the participants. As shown in FIG. **32**, on average, the participants experienced a significant improvement in blood flow velocity through the popliteal vein immediately after use, with the average increase in blood flow velocity at 1 minute being about 143%. The duration of continued increase in blood flow velocity relative to starting levels varied somewhat, but the average increase in blood flow velocity at 5 minutes was about 10%. Although the study specifically measured blood velocity, one of ordinary skill in the art, understanding the relationship between flow, velocity, and area (diameter of the vein) will understand that it is believed a corresponding increase in the volume of blood moving through the veins was realized.

Upon completion of an exercise session, exemplary methods in accordance with the present disclosure further contemplate that the configuration of the device **100** may be adjusted back from the open configuration to the closed configuration, for example, for storage, transport, or the like. In various embodiments, for example, the device **100** may be adjusted between the open configuration and the closed configuration by collapsing the pedal **101** against the base **102** to minimize the space S between the pedal **101** and the base **102**. As above, the pedal **101** may be collapsed, for example, by lowering the support **110** with respect to the base **102** (i.e., transitioning the support **110** between the upright and collapsed configurations as described above) by releasing the cord **116** that is attached to the support **110**.

It will be appreciated by those ordinarily skilled in the art having the benefit of this disclosure that the present disclosure provides various exemplary devices and methods for exercising muscles in an ankle, foot, and/or leg useful for increasing blood circulation in the lower extremities of the body. Furthermore, those ordinarily skilled in the art will understand that the disclosed exemplary devices and methods for exercising muscles in an ankle, foot, and/or leg may have other benefits and may treat other conditions, including, but not limited to, peripheral vascular disease, such as peripheral artery disease, PAD, and chronic venous insufficiency.

Further modifications and alternative embodiments of various aspects of the present disclosure will be apparent to those skilled in the art in view of this description. For example, although the particular examples and embodiments set forth herein contemplate an exercise device that receives one foot at a time, various additional exemplary embodiments in accordance with the present disclosure contemplate an exercise device that receives both feet at once, thereby simultaneously exercising muscles in both ankles, feet and/or legs.

Furthermore, the devices and methods may include additional components or steps that were omitted from the drawings for clarity of illustration and/or operation. Accordingly, this description is to be construed as illustrative only and is for the purpose of teaching those skilled in the art the general manner of carrying out the present disclosure. It is to be understood that the various embodiments shown and described herein are to be taken as exemplary. Elements and materials, and arrangements of those elements and materials, may be substituted for those illustrated and described herein,

parts and processes may be reversed, and certain features of the present disclosure may be utilized independently, all as would be apparent to one skilled in the art after having the benefit of the description herein. Changes may be made in the elements described herein without departing from the spirit and scope of the present disclosure and following claims, including their equivalents.

It is to be understood that the particular examples and embodiments set forth herein are non-limiting, and modifications to structure, dimensions, materials, and methodologies may be made without departing from the scope of the present disclosure.

Furthermore, this description's terminology is not intended to limit the present disclosure. For example, spatially relative terms—such as “beneath”, “below”, “lower”, “above”, “upper”, “bottom”, “right”, “left” and the like—may be used to describe one element's or feature's relationship to another element or feature as illustrated in the figures. These spatially relative terms are intended to encompass different positions (i.e., locations) and orientations (i.e., rotational placements) of a device in use or operation in addition to the position and orientation shown in FIGS. 1-12.

For the purposes of this specification and appended claims, unless otherwise indicated, all numbers expressing quantities, percentages or proportions, and other numerical values used in the specification and claims, are to be understood as being modified in all instances by the term “about” if they are not already. Accordingly, unless indicated to the contrary, the numerical parameters set forth in the following specification and attached claims are approximations that may vary depending upon the desired properties sought to be obtained by the present disclosure. At the very least, and not as an attempt to limit the application of the doctrine of equivalents to the scope of the claims, each numerical parameter should at least be construed in light of the number of reported significant digits and by applying ordinary rounding techniques.

Notwithstanding that the numerical ranges and parameters setting forth the broad scope of the present disclosure are approximations, the numerical values set forth in the specific examples are reported as precisely as possible. Any numerical value, however, inherently contains certain errors necessarily resulting from the standard deviation found in their respective testing measurements. Moreover, all ranges disclosed herein are to be understood to encompass any and all sub-ranges subsumed therein.

It is noted that, as used in this specification and the appended claims, the singular forms “a,” “an,” and “the,” and any singular use of any word, include plural referents unless expressly and unequivocally limited to one referent. As used herein, the term “include” and its grammatical variants are intended to be non-limiting, such that recitation of items in a list is not to the exclusion of other like items that can be substituted or added to the listed items.

It should be understood that while the present disclosure have been described in detail with respect to various exemplary embodiments thereof, it should not be considered limited to such, as numerous modifications are possible without departing from the broad scope of the appended claims, including the equivalents they encompass.

We claim:

1. A method for exercising muscles in an ankle, foot, and/or leg of a user, the method comprising:
positioning a foot of a user onto a first body of an exercise device, the first body being spaced away from a second body of the device and pivotably connected to the

second body of the device at a pivot axis, the pivot axis being adjacent to a central portion of the first body; rotating the first body about the pivot axis, with the foot, against a first resistive force, wherein rotating the first body comprises subjecting the foot to a first motion; positioning the foot of the user onto the second body; and rotating the second body about the pivot axis, with the foot, against a second resistive force, wherein rotating the second body comprises subjecting the foot to a second motion, the second motion being different than the first motion.

2. The method of claim 1, wherein the first body is spaced away from and pivotably connected to the second body via a movable support.

3. The method of claim 2, wherein rotating the first body about the pivot axis comprises rotating the first body in first and second directions about the pivot axis to cause a rocking movement of the first body about the pivot axis, while keeping the support substantially stationary.

4. The method of claim 2, wherein rotating the second body about the pivot axis comprises rotating the second body in first and second directions about the pivot axis to cause a rocking movement of both the second body and the support about the pivot axis.

5. The method of claim 1, wherein subjecting the foot to the first motion comprises pivoting the foot about an ankle of the foot.

6. The method of claim 1, wherein subjecting the foot to the second motion comprises pivoting the foot about an ankle of the foot while subjecting the ankle to a forward and aft rocking movement.

7. The method of claim 1, further comprising adjusting a configuration of the device between a closed configuration and an open configuration, wherein, in the closed configuration, the first body is collapsed against the second body, and, in the open configuration, the first body is spaced away from the second body.

8. The method of claim 7, wherein, in the open configuration, the first body is substantially parallel to the second body, and a movable support extends between and is substantially perpendicular to the first and second bodies.

9. The method of claim 8, wherein adjusting the configuration of the device between the closed configuration and the open configuration comprises transitioning the support between a collapsed position an upright position.

10. A method for exercising muscles in an ankle, foot, and/or leg of a user, the method comprising:

with a second body of an exercise device positioned on a support surface, the second body being substantially parallel to and spaced away from a first body of the device and pivotably connected to the first body of the device via a movable support structure, positioning a foot of a user onto the first body of the exercise device; rotating the first body about a pivot axis, with the foot, while keeping the support structure substantially stationary, wherein rotating the first body comprises subjecting the foot to a first motion;

with the first body of the exercise device positioned on the support surface, the first body being substantially parallel to and spaced away from the second body of the device, positioning the foot of the user onto the second body; and

rotating the second body about the pivot axis, with the foot, while moving the support structure, wherein rotating the second body comprises subjecting the foot to a second motion, the second motion being different than the first motion.

11. The method of claim 10, wherein the pivot axis is positioned adjacent to a central portion of the first body.

12. The method of claim 10, wherein rotating the first body about the pivot axis comprises rotating the first body in first and second directions about the pivot axis to cause a rocking movement of the first body about the pivot axis.

13. The method of claim 12, wherein rotating the first body in the first and second directions about the pivot axis comprises rotating the first body against a first resistive force in each of the first and second directions.

14. The method of claim 10, wherein rotating the second body about the pivot axis comprises rotating the second body in first and second directions about the pivot axis to cause a rocking movement of both the second body and the support structure about the pivot axis.

15. The method of claim 14, wherein rotating the second body in the first and second directions about the pivot axis comprises rotating the second body against a second resistive force in each of the first and second directions.

16. The method of claim 10, wherein subjecting the foot to the first motion comprises pivoting the foot about an ankle of the foot.

17. The method of claim 10, wherein subjecting the foot to the second motion comprises pivoting the foot about an ankle of the foot while subjecting the ankle to a forward and aft rocking movement.

18. The method of claim 10, further comprising adjusting a configuration of the device between a closed configuration and an open configuration.

19. The method of claim 18, wherein, in the closed configuration, the first body and the support structure are collapsed against the second body, and, in the open configuration, the support structure extends between and is substantially perpendicular to the first and second bodies to create a space between the first and second bodies.

20. The method of claim 19, wherein adjusting the configuration of the device between the closed configuration and the open configuration comprises transitioning the support structure between a collapsed position an upright position.

21. The method of claim 10, further comprising, prior to positioning the foot of the user onto the second body, flipping the exercise device over to position the first body of the exercise device on the support surface.

22. The method of claim 10, further comprising positioning the second body on the support surface prior to positioning a foot of a user onto the first body of the exercise device.

23. The method of claim 10, wherein the support surface comprises a floor or a ground surface.

* * * * *