



US011266785B2

(12) **United States Patent**  
**Simpson et al.**

(10) **Patent No.:** **US 11,266,785 B2**

(45) **Date of Patent:** **\*Mar. 8, 2022**

(54) **MEDICAL CONNECTOR WITH INTERNAL VALVE MEMBER MOVABLE WITHIN MALE PROJECTION**

(71) Applicant: **ICU Medical, Inc.**, San Clemente, CA (US)

(72) Inventors: **Philip J. Simpson**, Escondido, CA (US); **Walter D. Gillespie**, San Diego, CA (US); **David G. Matsuura**, Encinitas, CA (US)

(73) Assignee: **ICU Medical, Inc.**, San Clemente, CA (US)

(\* ) Notice: Subject to any disclaimer, the term of this patent is extended or adjusted under 35 U.S.C. 154(b) by 14 days.

This patent is subject to a terminal disclaimer.

(21) Appl. No.: **16/162,286**

(22) Filed: **Oct. 16, 2018**

(65) **Prior Publication Data**  
US 2019/0046731 A1 Feb. 14, 2019

**Related U.S. Application Data**

(63) Continuation of application No. 15/916,778, filed on Mar. 9, 2018, now Pat. No. 10,105,492, which is a (Continued)

(51) **Int. Cl.**  
**A61M 5/31** (2006.01)  
**A61M 39/26** (2006.01)  
(Continued)

(52) **U.S. Cl.**  
CPC ..... **A61M 5/31** (2013.01); **A61M 5/3134** (2013.01); **A61M 39/10** (2013.01); **A61M 39/22** (2013.01);  
(Continued)

(58) **Field of Classification Search**  
CPC ..... A61M 39/10; A61M 39/22; A61M 39/26; A61M 2039/2473; A61M 2039/2486;  
(Continued)

(56) **References Cited**  
**U.S. PATENT DOCUMENTS**  
2,254,997 A 9/1941 Fisher  
2,456,045 A 12/1948 Brock  
(Continued)

**FOREIGN PATENT DOCUMENTS**  
CA 2747283 A1 7/2002  
EP 0 158 030 10/1985  
(Continued)

**OTHER PUBLICATIONS**  
U.S. Appl. No. 14/020,579, filed Oct. 22, 2015, Fangrow et al.  
U.S. Appl. No. 15/499,740, filed Apr. 27, 2017, Fangrow.  
U.S. Appl. No. 15/789,242, filed Oct. 20, 2016, Fangrow, Jr. et al.  
(Continued)

*Primary Examiner* — Kami A Bosworth  
(74) *Attorney, Agent, or Firm* — Knobbe Martens Olson & Bear, LLP

(57) **ABSTRACT**  
Disclosed herein is a valve assembly comprising a male luer end portion and a female luer end portion and a passage for the transfer of fluids extending between the male and female luer end portions, valve means movable between a first position, in which the passage is closed, and a second position, in which the passage is open, biasing means for biasing the valve means toward the first position, and actuating means extending into the male luer end portion and coupled to the valve means to actuate the valve means when a female luer end portion of a medical accessory is engaged with the male luer end portion.

**18 Claims, 15 Drawing Sheets**

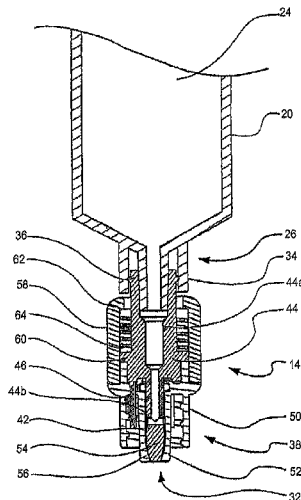

**Related U.S. Application Data**

continuation of application No. 15/648,147, filed on Jul. 12, 2017, now Pat. No. 9,913,945, which is a continuation of application No. 14/052,592, filed on Oct. 11, 2013, now Pat. No. 9,707,346, which is a continuation of application No. 13/305,663, filed on Nov. 28, 2011, now Pat. No. 8,556,868, which is a continuation of application No. 12/789,255, filed on May 27, 2010, now Pat. No. 8,066,692, which is a continuation of application No. 10/584,920, filed as application No. PCT/US2004/042723 on Dec. 21, 2004, now Pat. No. 7,758,566.

(60) Provisional application No. 60/532,916, filed on Dec. 30, 2003.

(51) **Int. Cl.**

*A61M 39/10* (2006.01)  
*A61M 39/22* (2006.01)  
*A61M 5/14* (2006.01)  
*A61M 5/168* (2006.01)  
*A61M 5/34* (2006.01)

(52) **U.S. Cl.**

CPC ..... *A61M 39/26* (2013.01); *A61M 5/14* (2013.01); *A61M 5/16881* (2013.01); *A61M 5/34* (2013.01); *A61M 2005/3103* (2013.01); *A61M 2005/3128* (2013.01); *A61M 2039/1033* (2013.01); *A61M 2039/1066* (2013.01); *A61M 2205/19* (2013.01)

(58) **Field of Classification Search**

CPC ..... *A61M 2039/261*; *A61M 2039/262*; *A61M 2039/263*; *A61M 2039/267*; *A61M 2039/268*; *A61M 2005/3128*  
 See application file for complete search history.

(56)

**References Cited**

U.S. PATENT DOCUMENTS

2,457,052 A 12/1948 Le Clair  
 2,485,006 A 10/1949 Main, Jr. et al.  
 2,842,382 A 7/1958 Franck  
 2,931,668 A 4/1960 Baley  
 2,968,497 A 1/1961 Treleman  
 3,127,892 A 4/1964 Bellamy, Jr. et al.  
 3,304,047 A 2/1967 Martin  
 3,334,860 A 8/1967 Bolton, Jr.  
 3,538,950 A 11/1970 Porteners  
 3,707,972 A 1/1973 Villari et al.  
 3,729,031 A 4/1973 Baldwin  
 3,824,556 A 7/1974 Berkovits et al.  
 3,986,508 A 10/1976 Barrington  
 4,055,179 A 10/1977 Manschot et al.  
 4,066,067 A 1/1978 Micheli  
 4,076,285 A 2/1978 Martinez  
 4,080,965 A 3/1978 Phillips  
 4,084,606 A 4/1978 Mittleman  
 4,121,585 A 10/1978 Becker, Jr.  
 4,133,441 A 1/1979 Mittleman et al.  
 4,143,853 A 3/1979 Abramson  
 4,150,845 A 4/1979 Kopacz et al.  
 4,187,848 A 2/1980 Taylor  
 4,195,632 A 4/1980 Parker et al.  
 4,233,982 A 11/1980 Bauer et al.  
 4,245,635 A 1/1981 Kontos  
 4,324,239 A 4/1982 Gordon et al.  
 4,334,551 A 6/1982 Pfister  
 4,340,049 A 7/1982 Munsch  
 4,379,458 A 4/1983 Bauer et al.  
 4,387,879 A 6/1983 Tauschinski  
 4,397,442 A 8/1983 Larkin

4,430,073 A 2/1984 Bemis et al.  
 4,436,125 A 3/1984 Blenkush  
 4,457,749 A 7/1984 Bellotti et al.  
 4,511,359 A 4/1985 Vaillancourt  
 4,538,836 A 9/1985 Kruetten  
 4,541,457 A 9/1985 Blenkush  
 4,576,359 A 3/1986 Oetiker  
 4,610,469 A 9/1986 Wolff-Mooij  
 4,619,640 A 10/1986 Potolsky et al.  
 4,623,332 A 11/1986 Lindmayer et al.  
 4,629,159 A 12/1986 Wellenstam  
 4,660,803 A 4/1987 Johnston et al.  
 4,662,878 A 5/1987 Lindmayer  
 4,673,400 A 6/1987 Martin  
 4,700,744 A 10/1987 Rutter et al.  
 4,723,603 A 2/1988 Plummer  
 4,723,948 A 2/1988 Clark et al.  
 4,728,075 A 3/1988 Paradis  
 4,745,950 A 5/1988 Mathieu  
 4,758,023 A 7/1988 Vermillion  
 4,774,964 A 10/1988 Bonaldo  
 4,774,965 A 10/1988 Rodriguez et al.  
 4,781,702 A 11/1988 Herrli  
 4,804,015 A 2/1989 Albinsson  
 4,816,024 A 3/1989 Sitar et al.  
 4,819,692 A 4/1989 Olson et al.  
 4,834,271 A 5/1989 Litwin  
 4,844,512 A 7/1989 Gahwiler  
 4,862,913 A 9/1989 Wildfang  
 4,863,201 A 9/1989 Carstens  
 4,883,483 A 11/1989 Lindmayer  
 4,915,687 A 4/1990 Sivert  
 4,917,669 A 4/1990 Bonaldo  
 4,935,010 A 6/1990 Cox et al.  
 4,949,745 A 8/1990 McKeon  
 4,950,260 A 8/1990 Bonaldo  
 D313,277 S 12/1990 Haininig  
 D314,050 S 1/1991 Sone  
 5,006,114 A 4/1991 Rogers et al.  
 5,021,059 A 6/1991 Kensey et al.  
 5,047,021 A 9/1991 Utterberg  
 5,065,783 A 11/1991 Ogle, II  
 5,066,286 A 11/1991 Ryan  
 5,070,885 A 12/1991 Bonaldo  
 5,083,819 A 1/1992 Bynum  
 5,098,385 A 3/1992 Walsh  
 5,108,376 A 4/1992 Bonaldo  
 5,122,123 A 6/1992 Vaillancourt  
 5,139,483 A 8/1992 Ryan  
 5,147,333 A 9/1992 Raines  
 5,154,703 A 10/1992 Bonaldo  
 5,176,406 A 1/1993 Straghan  
 RE34,223 E 4/1993 Bonaldo  
 5,199,948 A 4/1993 McPhee  
 5,201,717 A 4/1993 Wyatt et al.  
 5,201,726 A 4/1993 Kling  
 5,203,775 A 4/1993 Frank et al.  
 5,211,634 A 5/1993 Vaillancourt  
 5,215,537 A 6/1993 Lynn et al.  
 5,215,538 A 6/1993 Larkin  
 5,242,393 A 9/1993 Brimhall et al.  
 5,242,425 A 9/1993 White et al.  
 5,251,873 A 10/1993 Atkinson et al.  
 5,269,771 A 12/1993 Thomas et al.  
 5,273,533 A 12/1993 Bonaldo  
 5,279,571 A 1/1994 Larkin  
 5,281,206 A 1/1994 Lopez  
 5,284,475 A 2/1994 Mackal  
 5,295,657 A 3/1994 Atkinson  
 5,301,686 A 4/1994 Newman  
 5,306,243 A 4/1994 Bonaldo  
 5,312,377 A 5/1994 Dalton  
 5,324,270 A 6/1994 Kayan et al.  
 5,330,235 A 7/1994 Wagner et al.  
 5,330,450 A 7/1994 Lopez  
 5,334,159 A 8/1994 Turkel  
 5,344,414 A 9/1994 Lopez et al.  
 5,360,413 A 11/1994 Leason et al.  
 5,370,636 A 12/1994 Von Witzleben

(56)

## References Cited

## U.S. PATENT DOCUMENTS

5,380,306	A	1/1995	Brinon	5,782,818	A	7/1998	Werschmidt et al.
5,385,372	A	1/1995	Utterberg	5,784,750	A	7/1998	Sankovic et al.
5,390,898	A	2/1995	Smedley et al.	5,785,693	A	7/1998	Haining
5,391,150	A	2/1995	Richmond	5,788,215	A	8/1998	Ryan
5,395,348	A	3/1995	Ryan	5,806,831	A	9/1998	Paradis
5,397,314	A	3/1995	Farley et al.	5,810,398	A	9/1998	Matkovich
5,400,500	A	3/1995	Behnke et al.	5,814,024	A	9/1998	Thompson et al.
5,401,245	A	3/1995	Haining	5,820,601	A	10/1998	Mayer
5,402,826	A	4/1995	Molnar et al.	5,820,614	A	10/1998	Erksine et al.
5,402,982	A	4/1995	Atkinson et al.	5,830,189	A	11/1998	Chang
5,405,323	A	4/1995	Rogers et al.	5,839,715	A	11/1998	Leinsing
5,405,331	A	4/1995	Behnke et al.	5,848,994	A	12/1998	Richmond
5,405,333	A	4/1995	Richmond	5,947,954	A	9/1999	Bonaldo
5,411,499	A	5/1995	Dudar et al.	6,029,946	A	2/2000	Doyle
5,417,673	A	5/1995	Gordon	6,036,171	A	3/2000	Weinheimer et al.
5,423,791	A	6/1995	Bartlett	6,039,302	A	3/2000	Cote, Sr. et al.
5,425,465	A	6/1995	Healy	6,041,805	A	3/2000	Gydesen et al.
5,433,330	A	7/1995	Yatsko et al.	6,050,978	A	4/2000	Orr et al.
5,439,451	A	8/1995	Collinson et al.	6,063,062	A	5/2000	Paradis
5,441,487	A	8/1995	Vedder	6,068,011	A	5/2000	Paradis
5,445,623	A	8/1995	Richmond	6,068,617	A	5/2000	Richmond
5,447,177	A	9/1995	Ricken et al.	6,079,432	A	6/2000	Paradis
5,456,668	A	10/1995	Ogle, II	6,106,502	A	8/2000	Richmond
5,456,675	A	10/1995	Wolbring et al.	6,113,068	A	9/2000	Ryan
5,462,255	A	10/1995	Rosen et al.	6,142,446	A	11/2000	Leinsing
5,464,399	A	11/1995	Boettger	6,152,913	A	11/2000	Feith et al.
5,470,319	A	11/1995	Mayer	6,168,137	B1	1/2001	Paradis
5,470,327	A	11/1995	Helgren et al.	6,170,522	B1	1/2001	Tanida
5,474,536	A	12/1995	Bonaldo	6,171,287	B1	1/2001	Lynn et al.
5,480,393	A	1/1996	Bommarito	6,189,859	B1	2/2001	Rohrbough et al.
5,489,274	A	2/1996	Chu et al.	6,206,860	B1	3/2001	Richmond
5,492,147	A	2/1996	Challender et al.	6,221,029	B1	4/2001	Mathis et al.
5,501,426	A	3/1996	Atkinson et al.	6,224,578	B1	5/2001	Davis et al.
5,507,744	A	4/1996	Tay et al.	6,242,393	B1	6/2001	Ishida et al.
5,514,177	A	5/1996	Kurz et al.	6,245,048	B1	6/2001	Fangrow et al.
5,518,026	A	5/1996	Benjey	6,290,206	B1	9/2001	Doyle
5,520,665	A	5/1996	Fleetwood	6,299,132	B1	10/2001	Weinheimer et al.
5,520,666	A	5/1996	Choudhury et al.	6,325,100	B1	12/2001	Bunschoten et al.
5,527,284	A	6/1996	Ohnemus et al.	6,402,207	B1	6/2002	Segal et al.
5,533,708	A	7/1996	Atkinson et al.	6,428,520	B1	8/2002	Lopez
5,533,983	A	7/1996	Haining	6,431,219	B1	8/2002	Redler et al.
5,533,996	A	7/1996	Murphey et al.	6,485,472	B1	11/2002	Richmond
5,535,785	A	7/1996	Werge et al.	6,499,719	B1	12/2002	Clancy et al.
5,540,661	A	7/1996	Tomisaka et al.	6,508,792	B2	1/2003	Szames et al.
5,549,566	A	8/1996	Elias et al.	6,508,807	B1	1/2003	Peters
5,549,577	A	8/1996	Siegel et al.	6,541,802	B2	4/2003	Doyle
5,549,651	A	8/1996	Lynn	6,543,745	B1	4/2003	Enerson
5,552,118	A	9/1996	Mayer	6,581,906	B2	6/2003	Pott et al.
5,555,908	A	9/1996	Edwards et al.	6,585,229	B2	7/2003	Cote et al.
5,569,235	A	10/1996	Ross et al.	6,595,964	B2	7/2003	Finley et al.
5,573,516	A	11/1996	Tyner	6,595,981	B2	7/2003	Huet
5,575,769	A	11/1996	Vaillancourt	6,609,696	B2	8/2003	Enerson
5,578,059	A	11/1996	Patzer	6,612,624	B1	9/2003	Segal et al.
5,584,819	A	12/1996	Kopfer	6,666,852	B2	12/2003	Niedospial, Jr.
5,591,137	A	1/1997	Stevens	6,673,059	B2	1/2004	Guala
5,591,143	A	1/1997	Trombley, III et al.	6,695,817	B1	2/2004	Fangrow
5,597,536	A	1/1997	Mayer	6,745,998	B2	6/2004	Doyle
5,616,129	A	4/1997	Mayer	6,808,161	B1	10/2004	Hishikawa
5,616,130	A	4/1997	Mayer	6,840,501	B2	1/2005	Doyle
RE35,539	E	6/1997	Bonaldo	6,843,513	B2	1/2005	Guala
5,643,224	A	7/1997	Szapiro et al.	6,869,426	B2	3/2005	Ganem
5,645,538	A	7/1997	Richmond	6,875,205	B2	4/2005	Leinsing
5,651,776	A	7/1997	Appling et al.	6,893,056	B2	5/2005	Guala
5,674,206	A	10/1997	Allton et al.	6,899,315	B2	5/2005	Maiville et al.
5,676,346	A	10/1997	Leinsing	6,911,025	B2	6/2005	Miyahara
5,685,866	A	11/1997	Lopez	6,955,669	B2	10/2005	Curutcharry
5,685,868	A	11/1997	Lundquist	6,964,406	B2	11/2005	Doyle
5,699,821	A	12/1997	Paradis	7,004,934	B2	2/2006	Vaillancourt
5,700,248	A	12/1997	Lopez	7,037,302	B2	5/2006	Vaillancourt
5,702,374	A	12/1997	Johnson	7,040,598	B2	5/2006	Raybuck
5,709,243	A	1/1998	Wells et al.	7,044,441	B2	5/2006	Doyle
5,735,826	A	4/1998	Richmond	7,100,891	B2	9/2006	Doyle
5,738,144	A	4/1998	Rogers	7,125,396	B2	10/2006	Leinsing et al.
5,749,861	A	5/1998	Guala et al.	7,137,654	B2	11/2006	Segal et al.
RE35,841	E	7/1998	Frank et al.	7,140,592	B2	11/2006	Phillips
				7,160,272	B1	1/2007	Eyal et al.
				7,182,313	B2	2/2007	Doyle
				7,195,228	B2	3/2007	Tiberghien et al.
				7,244,249	B2	7/2007	Leinsing et al.

(56)

## References Cited

## U.S. PATENT DOCUMENTS

7,306,197	B2	12/2007	Parrino et al.
7,306,198	B2	12/2007	Doyle
7,306,566	B2	12/2007	Raybuck
7,316,679	B2	1/2008	Bierman
7,347,458	B2	3/2008	Rome et al.
7,350,764	B2	4/2008	Raybuck
7,361,164	B2	4/2008	Simpson et al.
7,497,484	B2	3/2009	Ziman
7,559,530	B2	7/2009	Korogi et al.
7,588,563	B2	9/2009	Guala
7,628,781	B2	12/2009	Roy et al.
7,645,274	B2	1/2010	Whitley
7,651,481	B2	1/2010	Raybuck
7,666,170	B2	2/2010	Guala
7,722,090	B2	5/2010	Burton et al.
7,758,566	B2	7/2010	Simpson et al.
7,766,304	B2	8/2010	Phillips
7,766,897	B2	8/2010	Ramsey et al.
7,803,139	B2	9/2010	Fangrow, Jr.
7,803,140	B2	9/2010	Fangrow, Jr.
7,815,614	B2	10/2010	Fangrow, Jr.
7,837,658	B2	11/2010	Cote et al.
7,857,805	B2	12/2010	Raines
7,875,019	B2	1/2011	Barron et al.
7,976,532	B2	7/2011	Kitani et al.
7,998,134	B2	8/2011	Fangrow et al.
8,066,692	B2	11/2011	Simpson et al.
8,177,772	B2	5/2012	Christensen et al.
8,196,614	B2	6/2012	Kriheli
8,211,069	B2	7/2012	Fangrow, Jr.
8,225,826	B2	7/2012	Horppu et al.
8,231,567	B2	7/2012	Tennican et al.
8,262,628	B2	9/2012	Fangrow, Jr.
8,281,824	B2	10/2012	Molema et al.
8,286,936	B2	10/2012	Kitani et al.
8,287,513	B2	10/2012	Elistrom et al.
8,414,554	B2	4/2013	Garfield et al.
8,414,555	B2	4/2013	Garfield et al.
8,454,579	B2	6/2013	Fangrow, Jr.
8,556,868	B2	10/2013	Simpson et al.
8,647,310	B2	2/2014	Fangrow, Jr. et al.
8,679,090	B2	3/2014	Anderson et al.
8,721,628	B2	5/2014	Ziman
8,777,908	B2	7/2014	Fangrow, Jr.
8,777,909	B2	7/2014	Fangrow, Jr.
8,864,737	B2	10/2014	Hasegawa et al.
8,888,758	B2	11/2014	Mansour et al.
8,899,267	B2	12/2014	Diodati et al.
9,114,242	B2	8/2015	Fangrow et al.
9,126,028	B2	9/2015	Fangrow et al.
9,126,029	B2	9/2015	Fangrow et al.
9,168,366	B2	10/2015	Fangrow et al.
9,345,641	B2	5/2016	Kraus et al.
9,358,379	B2	6/2016	Fangrow
9,592,344	B2	3/2017	Simpson et al.
9,636,492	B2	5/2017	Fangrow, Jr.
9,707,346	B2	7/2017	Simpson et al.
9,724,504	B2	8/2017	Fangrow, Jr. et al.
9,913,945	B2	3/2018	Simpson et al.
9,933,094	B2	4/2018	Fangrow
9,974,939	B2	5/2018	Fangrow, Jr.
9,974,940	B2	5/2018	Fangrow, Jr.
10,046,154	B2	8/2018	Fangrow et al.
10,105,492	B2	10/2018	Simpson
10,156,306	B2	12/2018	Fangrow
10,697,570	B2	6/2020	Fangrow
10,716,928	B2	7/2020	Fangrow et al.
10,842,982	B2	11/2020	Fangrow, Jr.
2002/0066715	A1	6/2002	Niedospial, Jr.
2003/0066978	A1	4/2003	Enerson
2003/0136932	A1	7/2003	Doyle
2003/0208165	A1	11/2003	Christensen et al.
2004/0074541	A1	4/2004	Sharpe
2004/0124388	A1	7/2004	Kiehne
2004/0124389	A1	7/2004	Phillips
2004/0244848	A1	12/2004	Maldavs
2005/0015075	A1	1/2005	Wright et al.
2005/0090805	A1	4/2005	Shaw et al.
2005/0124942	A1	6/2005	Richmond
2005/0228362	A1	10/2005	Vaillancourt
2006/0025751	A1	2/2006	Roy et al.
2006/0058734	A1	3/2006	Phillips
2006/0065873	A1	3/2006	Doyle
2006/0129109	A1	6/2006	Shaw et al.
2006/0142730	A1	6/2006	Proulx et al.
2006/0142735	A1	6/2006	Whitley
2006/0149213	A1	7/2006	Raybuck
2006/0157984	A1	7/2006	Rome et al.
2006/0161115	A1	7/2006	Fangrow
2006/0202146	A1	9/2006	Doyle
2006/0253084	A1	11/2006	Nordgren
2007/0043334	A1	2/2007	Guala
2007/0088292	A1	4/2007	Fangrow
2007/0088293	A1	4/2007	Fangrow
2007/0088294	A1	4/2007	Fangrow
2007/0088327	A1	4/2007	Guala
2007/0102923	A1	5/2007	Niemela
2007/0179453	A1	8/2007	Lim et al.
2008/0103485	A1	5/2008	Kruger
2008/0190485	A1	8/2008	Guala
2008/0290657	A1	11/2008	McKeon, III
2009/0177170	A1	7/2009	Kitani et al.
2010/0063482	A1	3/2010	Mansour et al.
2010/0174242	A1	7/2010	Anderson et al.
2010/0253070	A1	10/2010	Cheon et al.
2011/0046572	A1	2/2011	Fangrow
2011/0062703	A1	3/2011	Lopez
2011/0175347	A1	7/2011	Okiyama
2011/0306931	A1	12/2011	Kamen et al.
2012/0031515	A1	2/2012	Whitaker
2012/0046636	A1	2/2012	Kriheli
2012/0089101	A1	4/2012	Carlyon et al.
2012/0316536	A1	12/2012	Carrez et al.
2013/0006211	A1	1/2013	Takemoto
2013/0035668	A1	2/2013	Kitani et al.
2013/0317483	A1	11/2013	Reichart et al.
2014/0020792	A1	1/2014	Kraus et al.
2014/0246616	A1	9/2014	Fangrow
2015/0051555	A1	2/2015	Fangrow, Jr.
2015/0258324	A1	9/2015	Chida et al.
2016/0213910	A1	7/2016	Fangrow, Jr. et al.
2016/0263367	A1	9/2016	Fangrow et al.
2017/0296801	A1	10/2017	Fangrow, Jr.
2018/0015275	A1	1/2018	Fangrow
2018/0036524	A1	2/2018	Fangrow, Jr.
2018/0172190	A1	6/2018	Fangrow
2018/0333568	A1	11/2018	Fangrow, Jr.
2019/0038886	A1	2/2019	Fangrow
2019/0078712	A1	3/2019	Fangrow
2020/0215319	A1	7/2020	Fangrow, Jr.
2020/0284385	A1	9/2020	Fangrow
2021/0162191	A1	6/2021	Fangrow
2021/0252267	A1	8/2021	Fangrow

## FOREIGN PATENT DOCUMENTS

EP	0 368 473	A2	5/1990
EP	0 791 371		8/1997
EP	0 795 342		9/1997
EP	1 050 318		11/2000
EP	1 946 792		7/2008
EP	2 123 322		11/2009
GB	2 116 277		9/1983
GB	2 118 440		11/1983
GB	2 353 078		2/2001
JP	56-72659	U1	6/1981
JP	58-13216		1/1983
JP	59-41429		3/1984
JP	60-89488		6/1985
JP	62-65779		4/1987
JP	63-175383		11/1988
JP	11-311234		11/1999
JP	2001-187990	A	7/2001
JP	2004-000483	A	1/2004

(56)

**References Cited**

FOREIGN PATENT DOCUMENTS

WO	WO 1988/08499	11/1988
WO	WO 1995/32748	12/1995
WO	WO 2001/03756	1/2001
WO	WO 2001/23026	4/2001
WO	WO 2002/096500	12/2002
WO	WO 2003/013646	2/2003
WO	WO 2004/060474	7/2004
WO	WO 2004/082756	9/2004
WO	WO 2006/076656	7/2006
WO	WO 2006/088858	8/2006
WO	WO 2006/124756	11/2006
WO	WO 2007/008511	1/2007
WO	WO 2007/112944	10/2007
WO	WO 2008/144447	11/2008
WO	WO 2009/095760	8/2009
WO	WO 2010/071848	6/2010
WO	WO 2011/139995	11/2011
WO	WO 2013/036854	3/2013

OTHER PUBLICATIONS

Air Embolism and Exsanguination from Separation of Two-Piece Side Port/Hemostasis Valve Cardiac Catheter Introducers, ECRI Institute, Jan. 1995, in 2 pages, [http://www.mdsr.ecri.org/summary/detail.aspx?doc\\_id=8098](http://www.mdsr.ecri.org/summary/detail.aspx?doc_id=8098).

EPO Search Report re EP Application No. 08 755 612.2, dated Feb. 23, 2012 in 5 pages.  
 EPO Examination Report re EP Application No. 08 755 612.2, dated Nov. 20, 2013 in 5 pages.  
 EPO Examination Report re EP Application No. 08 755 612.2, dated Dec. 5, 2012 in 6 pages.  
 Injection Site, Molded Products, Inc., Apr. 2, 2004, in 1 page, <https://web.archive.org/web/20040402123354/https://www.moldedproducts.com/injectionsite.htm>.  
 International Search Report for PCT/US2006/026124, dated Mar. 3, 2007 in 5 pgs.  
 International Written Opinion for PCT/US2006/026124, dated Jan. 10, 2008 in 11 pgs.  
 International Search Report and Written Opinion of International Application No. PCT/US2008/063797 dated Dec. 30, 2008 in 21 pages.  
 International Preliminary Report on Patentability, International Application No. PCT/US2008/063797 dated Nov. 17, 2009 in 11 pages.  
 International Search Report and Written Opinion for International Application No. PCT/US2004/042723, dated Jun. 28, 2005 in 16 pages.  
 International Written Opinion of International Application No. PCT/US2004/042723 dated Jul. 3, 2006 in 10 pages.  
 ICU Medical, Inc. U.S. Appl. No. 11/417,882, filed May 3, 2006.  
 ICU Medical, Inc. U.S. Appl. No. 11/417,923, filed May 3, 2006.  
 ICU Medical, Inc. U.S. Appl. No. 11/417,671, filed May 3, 2006.  
 ICU Medical, Inc. U.S. Appl. No. 11/417,648, filed May 3, 2006.  
 ICU Medical, Inc. U.S. Appl. No. 11/417,909, filed May 3, 2006.  
 ICU Medical, Inc. U.S. Appl. No. 15/789,242, filed Oct. 20, 2016.

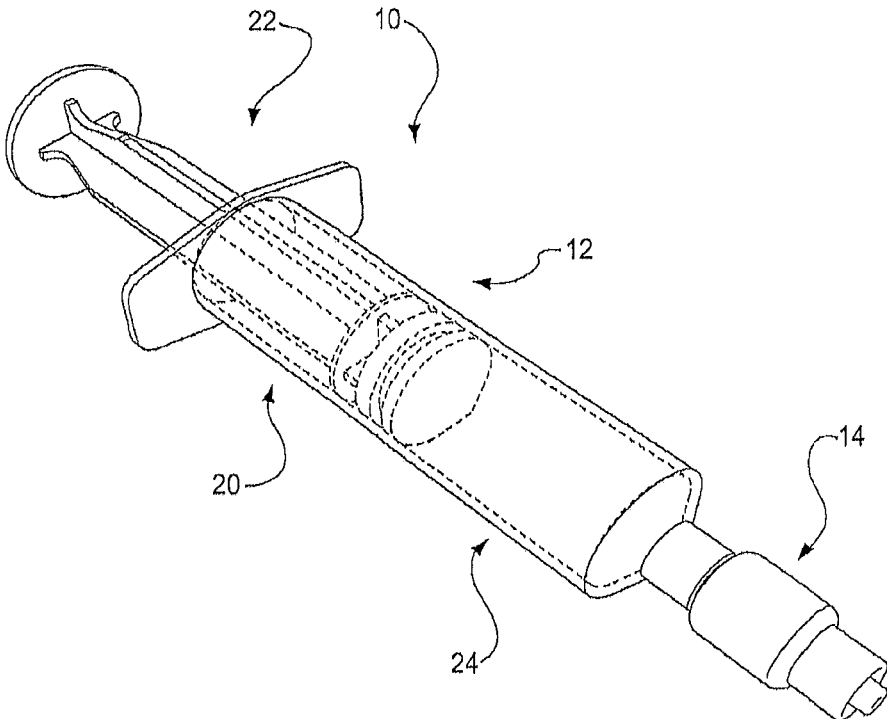

FIG. 1



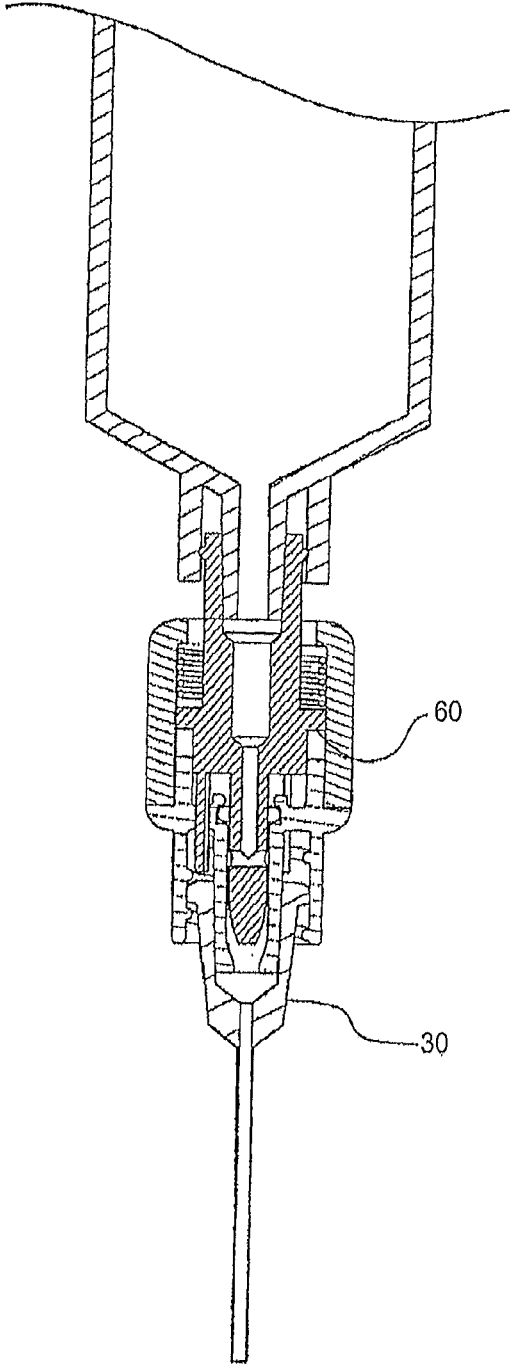

FIG. 3



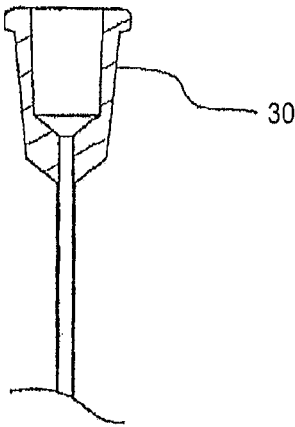
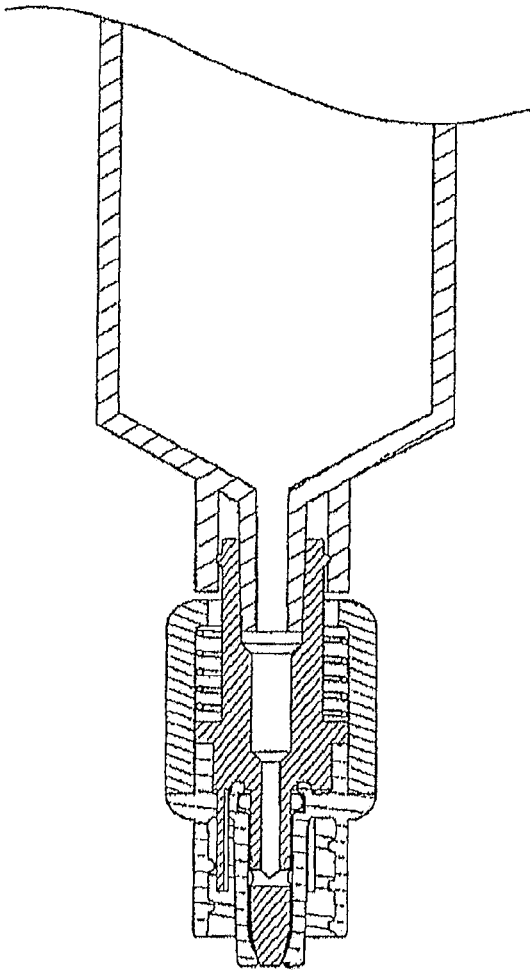

FIG. 4

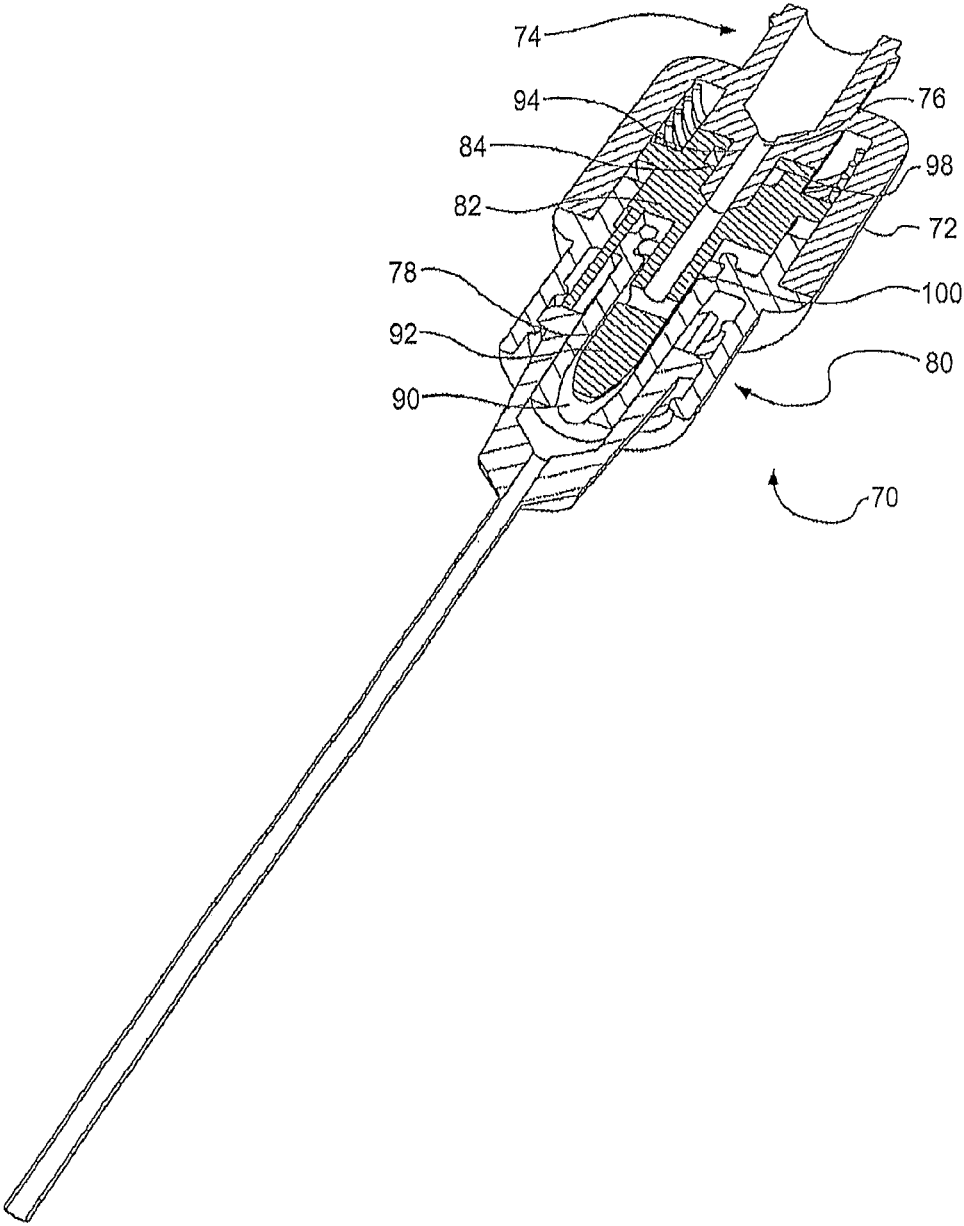

FIG. 5

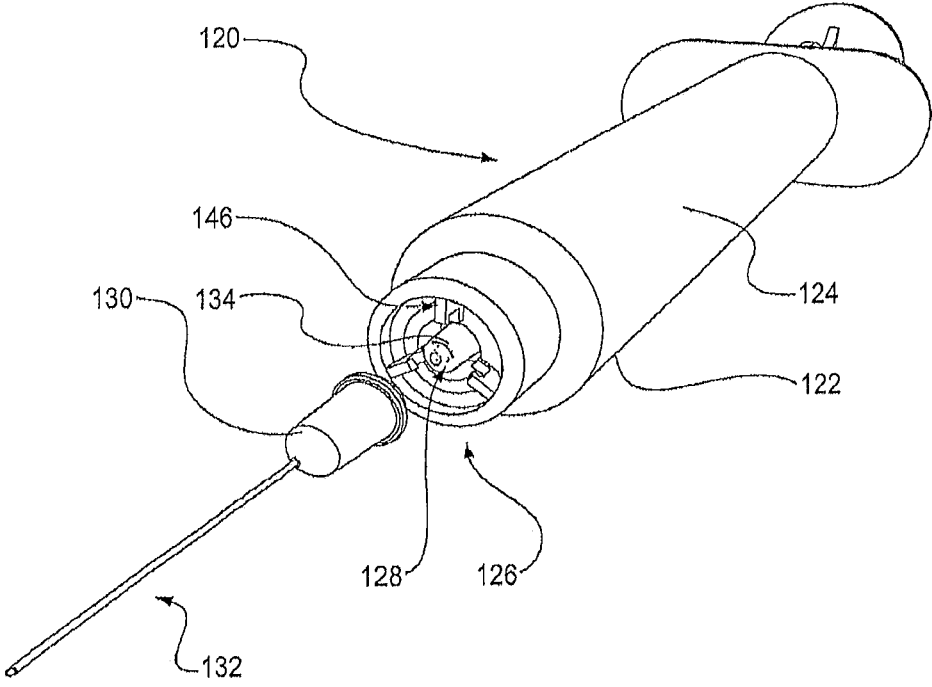

FIG. 6

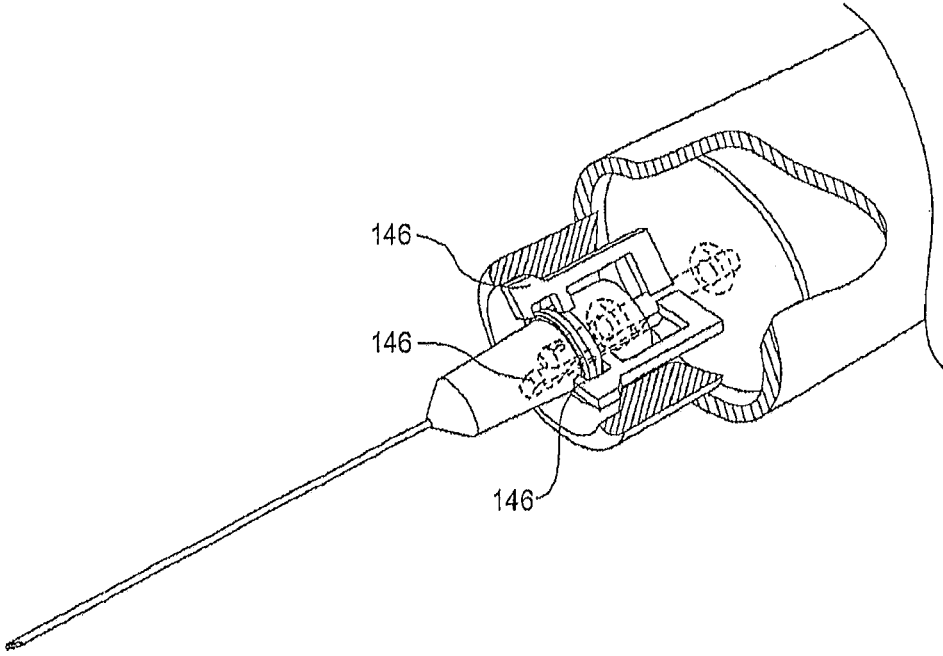

FIG. 7

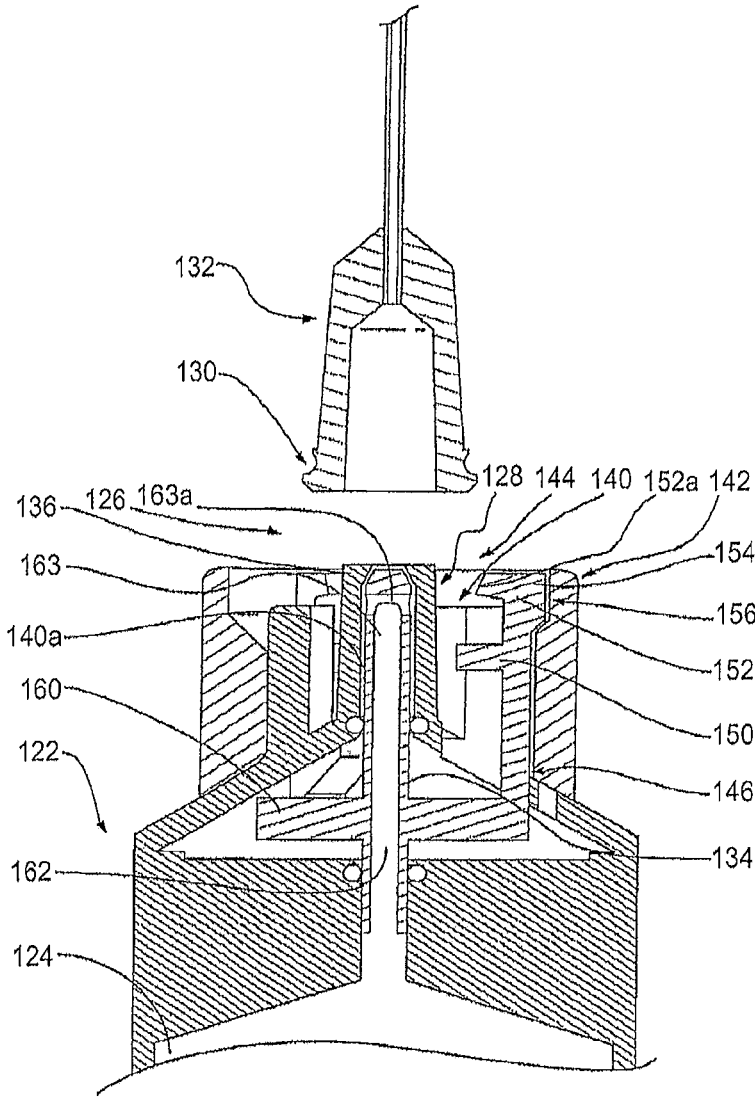

FIG. 8

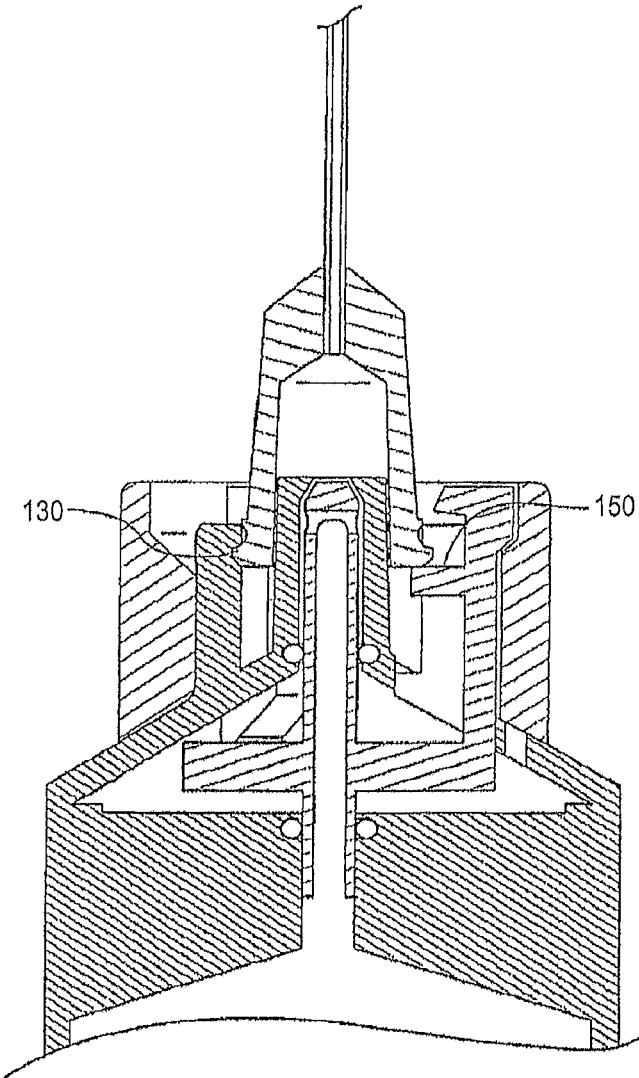

FIG. 9

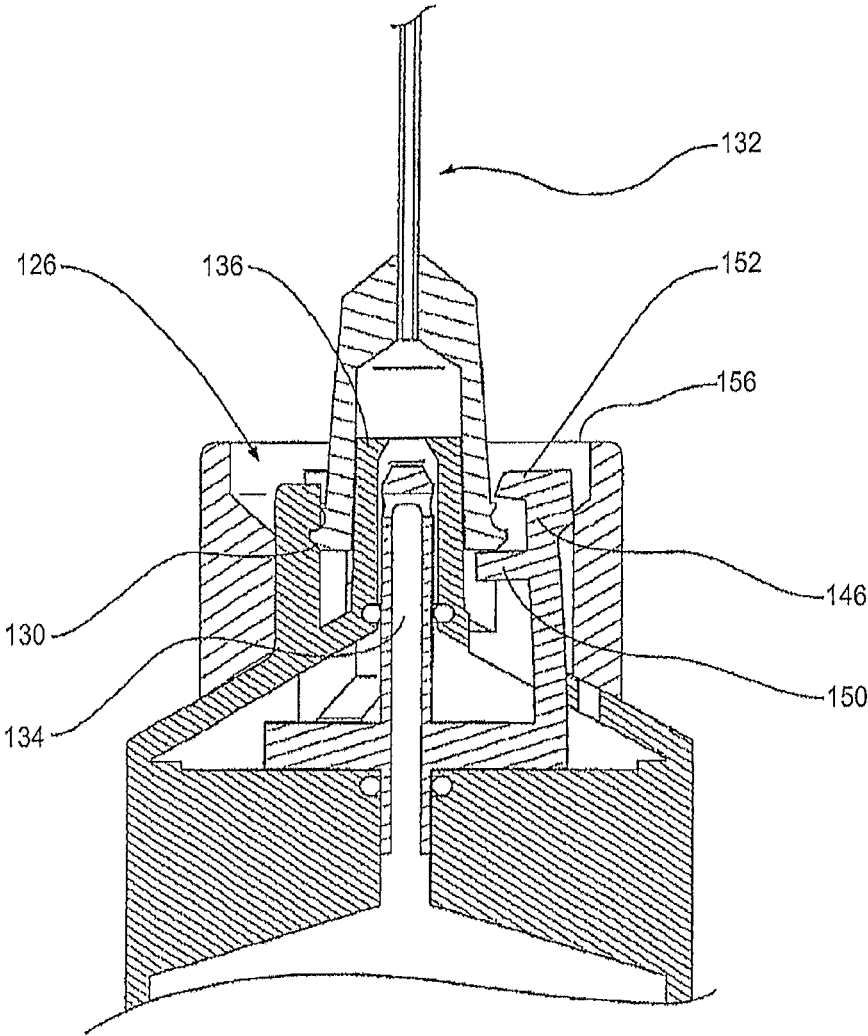

FIG. 10

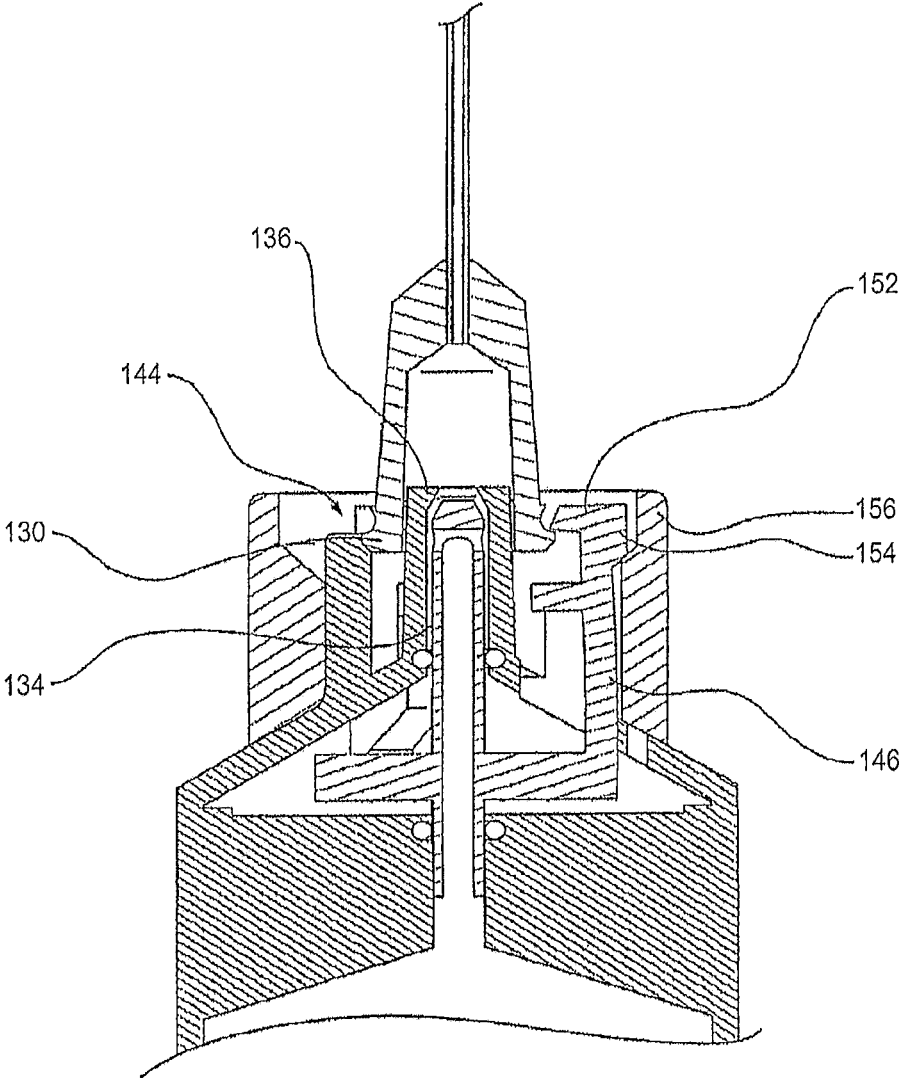

FIG. 11



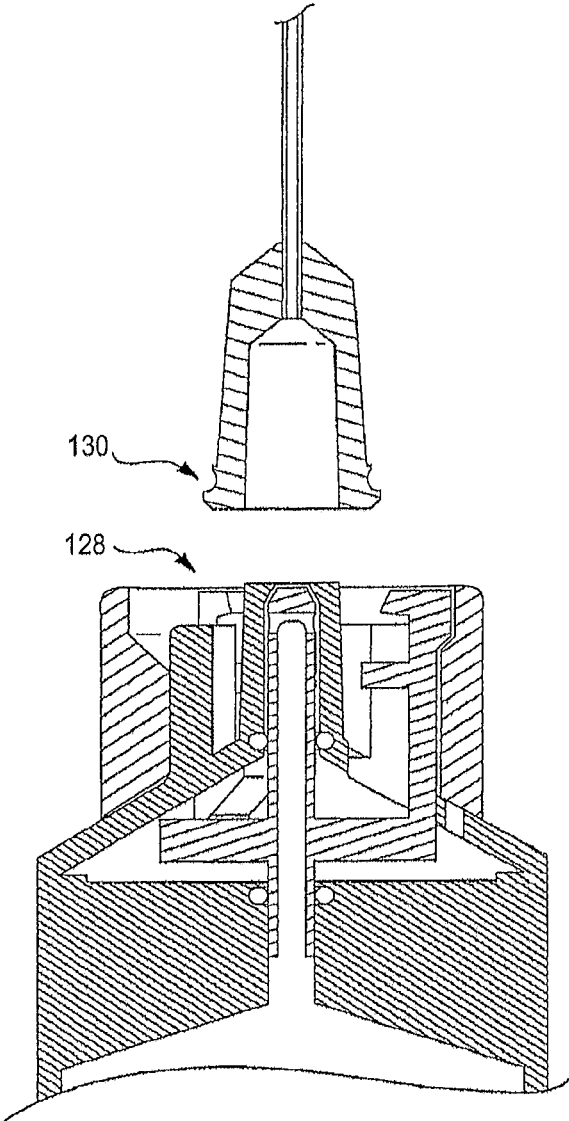

FIG. 12

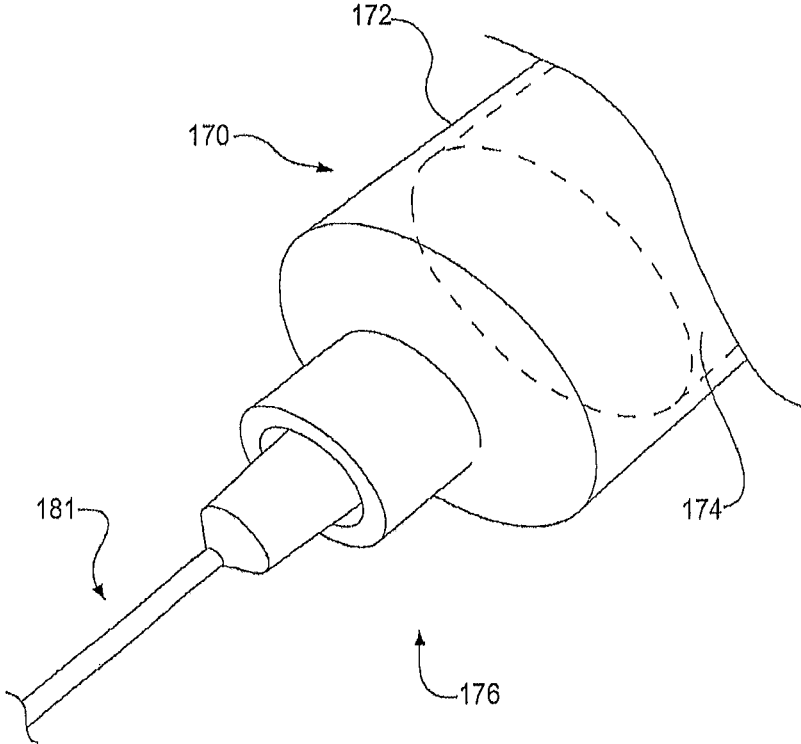

FIG. 13

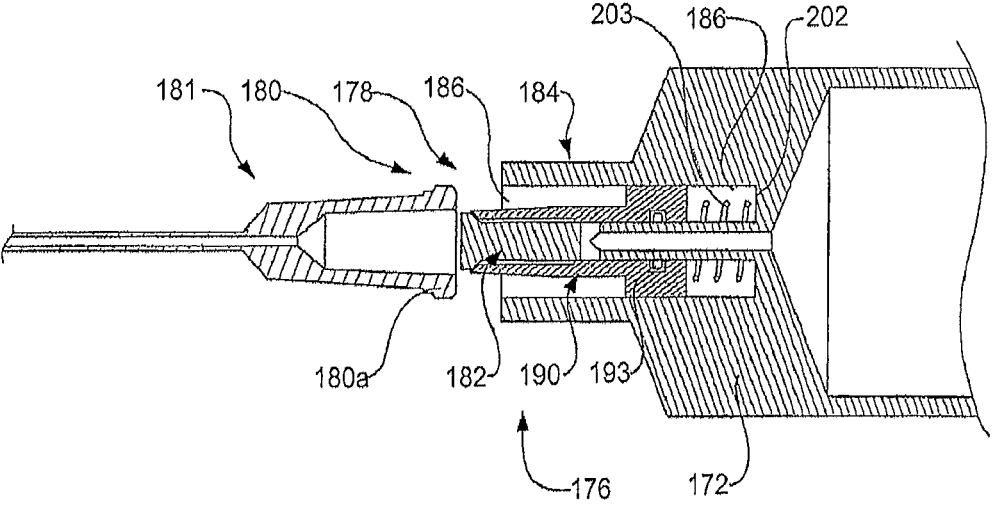

FIG. 14

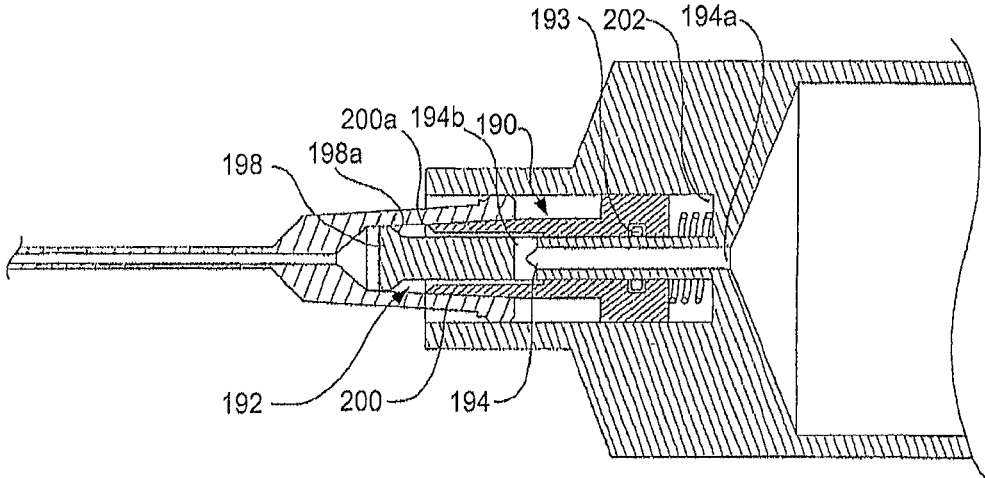

FIG. 15

**MEDICAL CONNECTOR WITH INTERNAL  
VALVE MEMBER MOVABLE WITHIN MALE  
PROJECTION**

CROSS-REFERENCE TO RELATED  
APPLICATIONS

This application is a continuation of U.S. patent application Ser. No. 15/916,778, filed Mar. 9, 2018, now U.S. Pat. No. 10,105,492, which is a continuation of U.S. patent application Ser. No. 15/648,147, filed Jul. 12, 2017, now U.S. Pat. No. 9,913,945, which is a continuation of U.S. patent application Ser. No. 14/052,592, filed Oct. 11, 2013, now U.S. Pat. No. 9,707,346, which is a continuation of U.S. patent application Ser. No. 13/305,663, filed Nov. 28, 2011, now U.S. Pat. No. 8,556,868, which is a continuation of U.S. patent application Ser. No. 12/789,255, filed May 27, 2010, now U.S. Pat. No. 8,066,692, which is a continuation of U.S. patent application Ser. No. 10/584,920, filed Dec. 28, 2006, now U.S. Pat. No. 7,758,566, which is the National Stage Entry of International Application No. PCT/US04/42723, filed Dec. 21, 2004, which claims the benefit of U.S. Provisional Application No. 60/532,916, filed Dec. 30, 2003; the entire contents of all of which are hereby incorporated by reference herein and made a part of this specification. Any and all priority claims identified in the Application Data Sheet, or any correction thereto, are hereby incorporated by reference under 37 CFR 1.57.

BACKGROUND OF THE INVENTION

Field of the Invention

The present invention relates to medical fluid delivery valves and more particularly to valve assemblies for use with syringes or other medical dispensing devices.

Description of the Related Art

Syringes are commonly used to deliver medications and other biological fluids to a patient. The syringe typically has a plunger which is sealingly engaged with an outer cylindrical chamber to form an inner fluid-receiving chamber. A 'male' luer fitting is usually provided at a delivery end of the chamber which receives a female luer fitting with a needle assembly or the like. The fluid channel joining the cavity to the luer fitting is usually open, so that when the needle is removed, the cavity is open to the environment. This is problematic since many medications and biological fluids are sensitive (or can degrade when exposed) to the environment.

It is therefore an object of the present invention to provide a novel valve assembly for use with a syringe or other medical dispensing devices, enabling the latter to be closed to the environment when in an unattached condition.

SUMMARY OF THE INVENTION

In one of its aspects, the present invention provides a valve assembly comprising a male luer end portion, a female luer end portion and a channel for the transfer of fluids between the male and female luer end portions, valve means movable between a closed position and an open position, biasing means for biasing the valve means toward the closed position, and actuating means extending into the male luer end portion and coupled to the valve means to actuate the

valve means when a female luer end portion of a medical accessory is coupled with the male luer end portion.

In an embodiment the male luer end portion has an inner projection and outer threaded sheath which is spaced therefrom to receive the female luer end portion therebetween. The actuating means includes an actuating member positioned between the outer threaded sheath and the inner projection.

In an embodiment, the valve means includes a valve seat and a valve member moveable relative thereto. The channel includes a first channel portion adjacent the female luer end portion and the inner projection includes a second channel portion. The valve member has a valve channel portion in fluid communication with the first and second channel portions. The valve seat is formed in the second channel portion and the valve member is integrally formed with the female luer end portion.

In one embodiment, the valve member includes an anchor flange extending outwardly toward an inner surface of the housing portion. In this case, the housing portion is coupled to the male luer end portion for movement therewith relative to the valve member. The male luer end portion engages the anchor flange when the valve means is in the closed position and the male luer end portion is spaced from said anchor flange when the valve means is in the open position. The housing portion terminates at an end region adjacent the female luer end portion, the biasing means includes a compression spring located within the housing between the end region and the outer anchor flange.

In another of its aspects, the present invention provides a medical dispensing device comprising a body having a chamber therein to contain a fluid material, a valve assembly in fluid communication with the chamber, the valve assembly having a male coupling member for engaging a female coupling member on a medical accessory to form a fluid coupling between the medical dispensing device and the medical accessory, the valve assembly further comprising flow control means operable to control fluid flow through the male coupling member, the flow control means being operable to be displaced by the female coupling member to open the male coupling member when female coupling member is operatively connected therewith, the flow control means being operable to be displaced by the female coupling member to close the male coupling member when the female coupling member is disconnected therefrom.

In one embodiment, the male coupling member includes an inner male portion and an outer sheath portion spaced therefrom to form a passage there between for receiving the female coupling member, the flow control means including at least one valve actuating portion positioned in the passage to abut the female coupling member and to displace the valve member during the travel of the female coupling member along the passage. The valve assembly includes a valve member and a valve seat, wherein the valve member is positioned against the seat to close the male coupling member. The valve actuating portion includes a pair of abutment elements which are spaced from one another along the passage to receive the female coupling member there between, wherein the pair of abutment elements are operable to travel with the female coupling member along the passage.

In one embodiment, the actuating portion is longitudinally oriented relative to the passage and the abutment elements are positioned along the actuating portion.

3

The valve member includes a back plate and a plurality of actuating portions equally spaced on the back plate, each of the actuating portions having first and second abutment elements.

In one embodiment, the valve actuating portion includes a locking flange which is adjacent one of the abutment elements. The valve assembly includes a locking seat to receive the locking flange when the male coupling member is in the closed position. The actuating portion has a distal end region, the locking flange being located adjacent the distal end region and the locking seat is formed in the outer sheath portion. The actuating portion is thus arranged to flex in order to displace the locking flange from the locking seat.

In yet another aspect, the present invention provides a medical dispensing device comprising a body having a chamber therein to contain a fluid material, a valve assembly in fluid communication with the chamber, the valve assembly having a male coupling member for engaging a female coupling member on a medical accessory to form a fluid coupling between the medical dispensing device and the medical accessory, the male coupling member including a projection and an outer valve member movable relative to the projection, the projection and the outer valve member forming a fluid channel there between, a sheath portion encircling the projection and spaced therefrom to form a passage to receive the female coupling member, the valve member being engageable with the female coupling member and movable relative to the projection to open the fluid channel when the female coupling member is connected with the male coupling member.

In one embodiment, the valve member forms an outer surface of the male coupling portion.

In an embodiment, biasing means is provided to bias the valve member toward an engaged position with the projection to close the fluid channel. In this particular case, the passage ends at an inner wall and the biasing means includes a spring located between the inner wall and the valve member.

In one embodiment, the projection is fixed to the body and includes an inner passage, the inner passage having one end which is open to the chamber and another end which is open to the fluid channel. The projection also includes an enlarged end portion, the valve member including an outer portion arranged to engage the enlarged end portion to close the fluid channel. In this case the enlarged end portion and the outer end portion on the valve member have mating bevelled surfaces.

In one embodiment, the female coupling member has a leading segment, the valve member being dimensioned to fit within the leading segment.

Preferably, the medical dispensing device includes such items as a syringe, an IV bottle, an IV line, a powder and/or atomized fluid and/or gas inhalant dispenser, an implant delivery dispenser, a ventilator, a syringe pump, an intubation tube, a gastrointestinal feeding tube or a plurality and/or a combination thereof.

Preferably, the medical material is in solid, liquid or gaseous form or a combination thereof and has beneficial properties to enhance life, to promote health, to cure and/or treat a disease, condition or ailment, to monitor and/or indicate a bodily function or a combination thereof. For example, the medical material may be useful for, among others, IV therapy, implantation, stem cell therapy, oncology therapy, blood transfusion and/or organ transplantation.

#### BRIEF DESCRIPTION OF THE DRAWINGS

Several preferred embodiments of the present invention will now be described, by way of example only, with reference to the appended drawings in which:

4

FIG. 1 is a perspective view of a syringe assembly;

FIG. 2 is a sectional view of a portion of the assembly of FIG. 1;

FIGS. 3 and 4 are sectional views of the assembly of FIG. 1 in two alternate operative positions;

FIG. 5 is a fragmentary sectional perspective view of a portion of another syringe assembly;

FIGS. 6 and 7 are fragmentary perspective views of another syringe assembly;

FIGS. 8 to 12 are fragmentary sectional views of the syringe assembly of FIG. 6;

FIG. 13 is a fragmentary perspective view of yet another syringe assembly; and

FIGS. 14 and 15 are fragmentary sectional views of the syringe assembly of FIG. 13 or portions thereof.

#### DESCRIPTION OF THE PREFERRED EMBODIMENTS

Referring to the figures, and in particular FIG. 1, there is provided a syringe assembly 10 comprising a syringe 12 and a valve unit 14. The syringe 12 has a chamber 20 containing a plunger 22 to form a cavity 24. Referring to FIG. 2, the cavity has an outlet 26 and the valve unit 14 is located downstream of the outlet 26 for coupling the cavity 24 with a medical accessory such as a needle 30 (as shown in FIGS. 3 and 4). The valve unit 14 has an outlet 32 and flow control means, as will be described, to control fluid flow through the outlet, the flow control means being operable to open the outlet when the coupling section is operatively connected with the medical accessory, the flow control means being operable to close the outlet when the valve unit is disconnected from the medical accessory and to remain closed until connected once again with a medical accessory.

In this case, the chamber 20 includes a first male luer end portion 34 adjacent the outlet 26 and the valve unit 14 includes a first female luer end portion 36 which is engageable with the male luer end portion 34. The valve unit 14 also includes a second male luer end portion 38 for coupling with the medical accessory 30.

Although the chamber 20 and the valve unit 14 are separate from one another in this case, it will be understood that they may, alternatively, be integrally formed, for example by combining the first male luer end portion 34 with the female luer end portion 36.

The valve unit 14 has a channel 42 for the transfer of fluids between the female and male luer end portions 36, 38. A valve means, in the form of a valve member 44 is located in the valve unit 14 and is movable between a first position (as shown in FIG. 2), in which the channel is closed, and a second position (as shown in FIG. 3), in which the channel is open. An actuating means, in the form of an actuating member 46 (shown in FIG. 2), extends outwardly from the valve member 44 and into the male luer end portion 38. The actuating member 46 is coupled to the valve member 44 to actuate it when a female luer end portion of the medical accessory 30 is engaged with the male luer end portion 38.

In the embodiment of FIGS. 1 to 4, the male luer end portion 38 has an outer threaded sheath 50 which is spaced from an inner projection 52. In this case, the actuating member 46 is positioned between the outer threaded sheath 50 and the inner projection 52. The valve member 44 includes a valve plug portion 54 moveable relative to a valve seat portion 56. The valve member 44 has an upper end which is integrally formed with the female luer end portion 36. An outer housing member 58 is slidably mounted on the valve member 44. In this case, the outer housing member 58

5

is joined to the male luer end portion 38. The valve member 44 also has a valve channel 44a extending from the female luer end portion 36 to the valve plug portion 42 where it terminates at one or more transverse flow openings 44b to join with the channel 42.

The valve member 44 includes an anchor flange 60, and the male luer end portion 38 seats, directly or indirectly, against the anchor flange 60 when the valve is in the closed position as viewed in FIG. 2. Conversely, the male luer end portion 38 is spaced from said anchor flange when the valve is in the open position as shown in FIG. 3.

The outer housing 58 terminates at a radially inwardly directed end region 62 adjacent the female luer end portion 34 and a biasing means in the form of a compression spring 64 is located within the outer housing between the end region 62 and the anchor flange 60 to bias the valve member toward the first position to close the valve unit.

An alternative arrangement is shown in FIG. 5. In this case, the valve unit 70 has a housing 72 which is integrally formed with the female luer end portion 74. A first channel portion 76 is adjacent the female luer end portion 74 and a second channel portion 78 is adjacent a male luer end portion 80. In this case, the valve means includes a valve member 82 having a valve channel 84 in fluid communication with the first and second channel portions 76 and 78. In this case, the valve seat portion is formed at 90 in the second channel portion 78.

The valve member 82 includes a plug portion 92 which is movable relative to and within the second channel portion 78 for engaging the seat portion 90 to close the second channel portion 78. The first channel portion 76 includes a tubular projection 94 extending from the female luer end portion 74. In this case, the valve channel 84 in the valve member 82 is coextensive with the first and second channel portions 76, 78. In this case, the tubular projection 94 is slidably engaged with the valve member 82 within the valve channel 84 and sealed therein by way of seal 98. Likewise, the valve member 84 is sealed within the second channel portion 78 by way of seal 100.

The syringe assembly 10 is used as follows. First, the valve unit 14 is joined to the syringe 12 by engaging the corresponding first male luer end portion 34 with the female luer end portion 36. In this condition, the second male luer end portion 38 is unattached with a medical accessory such as the needle 30 and the actuator 46 is fully extended into the second male luer end portion 38 as shown in FIG. 2. Consequently, the valve member 44 is biased to its closed position, thereby engaging the valve plug portion 54 against the valve seat 56.

The needle 30 is then attached to the syringe by engaging the female luer end portion on the needle 30 with the second male luer end portion 38. Doing so causes the female luer end portion on the needle 30 to abut and displace the actuating member 46, thereby causing the valve member 44 to be displaced upwardly (as viewed in FIG. 2) thereby releasing the valve plug portion 54 from its sealed abutment with the valve seat 56 to open the valve channel. The plunger 22 may then be displaced outwardly to cause fluids in the proximity of the pointed end of the needle 30 to be drawn into the cavity 24, by a path starting at the valve seat 56 through the channel 42 to the transverse flow openings 44b, to the valve channel 44a and on through the female luer end portion and into the cavity 24. The needle 30 may then be removed causing the actuating member 46 to be displaced downwardly (as viewed in FIG. 2) causing the immediate displacement of the valve plug portion to abut the seat 56 and thereby close the valve.

6

Another device is shown at 120 FIGS. 6 to 12, having a body 122 forming an inner chamber 124 therein to contain a fluid material. A valve assembly 126 is in fluid communication with the chamber 124 and has a male coupling member 128 for engaging a female coupling member 130 on a medical accessory (in this case a needle 132) to form a fluid coupling between the device 120 and the needle 132.

The valve assembly 126 is operable to control fluid flow through the male coupling member 128 and more particularly to be in an open position when the male coupling member 128 is operatively connected with the female coupling member 130 and, conversely, to be in a closed position when the male coupling member 128 is disconnected from the female coupling member 130.

In this case, the body 122 and the valve assembly 126 are integrally formed and, as seen in FIG. 8, the latter includes a valve member 134 and a valve seat 136. The valve member 134 is shown in its position against the valve seat 136 to close the male coupling member 128, but for a very minor gap there between for illustrative purposes only.

The male coupling member 128 includes an inner male portion 140 having an inner fluid channel 140a and an outer sheath portion 142 spaced from the inner male portion 140 to form a passage 144 there between for receiving the female coupling member 130. At least one, in this case three, valve actuating portions 146 (two being shown in FIG. 7) are positioned in the passage 144 to abut the female coupling member 130 and to displace the valve member during the travel of the female coupling member 130 along the passage 144. In this case, each valve actuating portion 146 is integrally formed with the valve member 134.

Each valve actuating portion 146 includes a pair of abutment elements 150, 152 which are spaced from one another along the passage 144 to receive the female coupling member 130 there between and to travel with the female coupling member along the passage 144. The abutment element 152 has a bevelled outer surface 152a for reasons to be described. Each actuating portion 146 is longitudinally oriented relative to the passage 144 and the abutment elements 150, 152 are positioned along the actuating portion 146.

Each valve actuating portion 146 includes a locking flange 154 and the valve assembly includes a locking seat 156 to receive the locking flange 154 when the valve member 134 is in the closed position. In this case, the valve actuating portion 146 has a distal end region and the locking flange 154 is located in the distal end region, while the locking seat 156 is formed in the outer sheath portion 142.

It will be seen in FIG. 10 that each valve actuating portion 146 is arranged to flex in order to displace the locking flange 154 out of the locking seat 156.

Referring to FIG. 8, the valve member 134 includes a back plate 160 and the actuating portions 146 are equally spaced on the back plate 160. The back plate 160 has a central fluid channel 162 which is in fluid communication with the chamber 124 and the valve member 134 has a fluid channel 163 therein in fluid communication with the central fluid channel 162 and hence the chamber 124. In addition, the fluid channel 163 has a lateral portion 163a which establishes fluid communication between the fluid channel 163 and an inner fluid channel 140a in the inner male portion.

The device 120 is thus used as follows. The valve assembly is set with the valve member in its closed position, that is with the valve member 134 in its position against the valve seat 136 as shown in FIG. 8. The female coupling member 130 on the needle 132 is aligned with the passage

144 and brought toward the male coupling member 128. The bevelled leading surface 152a on the abutment member 152 aids to centre the female coupling member on the mouth of the passage 144. With the locking flange 154 in the locking seat 156, the female coupling member 130 is able to pass the lowermost edge of the abutment element 152 and continue into the passage 144 until the female coupling member makes contact with the abutment element 150 as seen in FIG. 9. As seen in FIG. 10, continued inward force on the female coupling member is transferred to the abutment element 150 causing the abutment portion 146 to move inwardly along the passage and thus to draw the locking flange 154 from this locked position in the locking seat 156, causing the abutment portion 146 to flex, until the locking flange 154 is removed from the locking seat 156. At this position, it can be seen that the valve member 134 has moved from the valve seat 136 to open the fluid channel 163 to the needle 132.

Referring to FIG. 11, as the female coupling member 130 is removed from the passage 144, it makes contact with the abutment element 152 and causes the abutment portion 146 to move outwardly along the passage 144 and thus cause the valve member 134 to move toward the valve seat 136. The locking flange 154 approaches, and finally enters, the locking seat 156 to coincide with the closure of the valve assembly.

Thus, the device 120 does not make use of a valve member which is biased to its closed position as with the earlier embodiment, but rather relies on the displacement of the female coupling member 130 to draw the valve assembly to its closed position when it is removed from the male coupling member 128.

Another device is shown at 170 in FIGS. 13 to 15, having a body 172 providing a chamber 174 therein to contain a fluid material. A valve assembly 176 is in fluid communication with the chamber 174 and has a male coupling member 178 for engaging a female coupling member 180, again on a needle 181, to form a fluid coupling between the medical dispensing device 170 and the needle 181.

The valve assembly 176 is operable to control fluid flow through the male coupling member and more particularly to actuate or open the male coupling member 178 when operatively connected with the female coupling member 180 and, conversely, to close the male coupling member 178 when disconnected from the female coupling member 180.

In this case, the male coupling member 178 includes a projection 182 which is fixed to the body 172. A sheath portion 184 encircles the projection 182 and is also fixed to the body 172. The sheath portion 184 and is spaced from the projection 182 to form a passage 186 to receive the female coupling member 180.

A valve member 190 is movable relative to the projection 182 and forms a fluid channel 192 there between and sealed by an inner seal 193. The projection 182 includes an inner passage 194 which has one end 194a open to the chamber 174 and another end 194b which is open to the fluid channel 192.

Referring to FIGS. 14 and 15, the projection includes an enlarged end portion 198 and the valve member 190 has an outer portion 200 arranged to engage the enlarged end portion 198 to close the fluid channel 192. In this case, the passage 186 ends at an inner wall 202 and the valve member 190 is movable relative to the inner wall 202 under the action of a spring 203 which is positioned in the passage 186 between the valve member 190 and the inner wall 202 to

bias the outer end portion 200 of the valve member 190 toward an engaged position with the enlarged end portion 198.

As can be seen in FIG. 15, the enlarged end portion 198 and the outer end portion 200 on the valve member 190 have mating bevelled surfaces 198a and 200a respectively.

The valve member 190 is operable to engage the female coupling member 180 and to travel with the female coupling member 180 along the passage 186. In this case, the female coupling member 180 has a leading segment 180a and the outer end portion 200 of the valve member 190 is dimensioned to fit within the leading segment 180a.

In contrast to the device 120 of FIG. 6, the device 170 has a valve member 190 which is biased to the closed position. As the female coupling member 180 passes over the projection 182, the leading segment 180a of the female coupling member 180 rides over the outer end portion 200 of the valve element 190. Continued inward displacement of the female coupling member 180 into the passage 186 thus causes the valve member to move relative to the projection 182 until the mating bevelled surfaces 198a, 202a separate to open the fluid channel 192 to the needle. The fluid coupling is thus fully operational when the female and male coupling members are tightly engaged. When the female coupling member 180 is removed from the male coupling member 178, the valve member 190 is returned to its closed position against the projection 198 under the biasing action of the spring 203, to close the male coupling member.

While the present invention has been described for what are presently considered the preferred embodiments, the invention is not so limited. To the contrary, the invention is intended to cover various modifications and equivalent arrangements included within the spirit and scope of the appended claims. The scope of the following claims is to be accorded the broadest interpretation so as to encompass all such modifications and equivalent structures and functions.

The valve unit may be used with other medical fluid delivery devices, such as IV lines, catheters, infusion pumps and the like. The valve unit may also be used on syringes and other medical devices which do not employ the ubiquitous luer coupling arrangement.

The following is claimed:

1. A method of providing a medical connector, the method comprising:
  - providing a housing including a proximal portion and a distal portion;
  - providing a female luer;
  - providing a male luer projection being located at the distal portion of the housing; and
  - providing a valve member being longitudinally movable between a closed position and an open position, the valve member comprising:
    - an internal fluid pathway,
    - a proximal end being moveable between the open position and the closed position, the moveable proximal end comprising an open-ended proximal end surface,
    - at least one distal opening, and
    - a distal end portion being located in a distal direction from the at least one distal opening, the distal end portion being configured to obstruct fluid communication between the male luer projection and the internal fluid pathway when in the closed position, wherein the valve member when in the closed position is configured to inhibit fluid flow through the internal fluid pathway, wherein the valve member when in



9

the open position is configured to allow fluid flow through the internal fluid pathway, wherein at least a portion of the valve member is positioned within the male luer projection in the closed position, wherein at least a portion of the valve member is positioned outside of the male luer projection in both the open position and the closed position, and wherein the valve member is biased toward the closed position.

2. The method of claim 1, wherein the open-ended proximal end surface is wider than a distal-most end tip of the valve member.

3. The method of claim 1, wherein the valve member is formed of a single piece of material.

4. The method of claim 3, wherein the at least one distal opening of the valve member comprises two distal openings.

5. The method of claim 1, wherein the distal end portion of the valve member comprises a plug.

6. The method of claim 1 further comprising providing an actuating member being configured to actuate at least a portion of the valve member from the closed position to the open position.

7. The method of claim 1, wherein the valve member extends along the housing from:

- (i) a first region of the medical connector that is configured to receive an end of a medical article, to
- (ii) a second region of the medical connector containing the male luer projection.

8. The medical connector of claim 1 further comprising providing a biasing member being configured to assert a restoring force on the valve member, the restoring force being configured to move the valve member longitudinally within the housing to the closed position, wherein the biasing member contacts a proximal half of the valve member.

9. A method of providing a medical connector configured to receive a male end of a medical article, the method comprising:

- providing a housing comprising a proximal region and a distal region being separate from the proximal region, the proximal region being joined with the distal region;
- providing a female luer end being configured to receive a male end of a medical article;
- providing a male luer projection;
- providing a threaded shroud surrounding at least a portion of the male luer projection, the threaded shroud comprising one or more threads;
- providing a valve member being longitudinally movable between a closed position and an open position, the valve member comprising:
  - an internal fluid pathway,
  - at least one opening being moveable with the valve member and comprising a distal end being located distal from a proximal end of the one or more threads of the threaded shroud in the open position, and

10

- a distal end portion being located in a distal direction from the at least one opening, the distal end portion being configured to inhibit fluid communication between the male luer projection and the internal fluid pathway when in the closed position, the distal end portion comprising a distal-most end tip being positioned within the male luer projection in both the open position and the closed position, wherein a proximal-most end of the valve member is wider than the distal-most end tip,
- wherein the valve member when in the closed position is configured to inhibit fluid flow between the internal fluid pathway and the male luer projection, wherein the valve member when in the open position is configured to allow fluid flow between the internal fluid pathway and the male luer projection through the at least one opening, and
- wherein the valve member is biased toward the closed position; and
- positioning the valve member within the housing such that at least a portion of the valve member is located outside of the male luer projection when the valve member is in both the open position and the closed position.

10. The method of claim 9, wherein at least a portion of the valve member is positioned within the male luer projection in the closed position.

11. The method of claim 9, wherein the proximal-most end of the valve member comprises a proximal-facing opening.

12. The method of claim 9, wherein the at least one opening of the valve member further comprises two distal openings.

13. The method of claim 9, wherein the valve member is formed of a single piece of material.

14. The method of claim 13, wherein the valve member extends along the housing from:

- (i) a first region of the medical connector that is configured to receive the male end of the medical article, to
- (ii) a second region of the medical connector containing the male luer projection.

15. The method of claim 9, wherein the distal-most end tip of the valve member comprises a plug.

16. The method of claim 9 further comprising providing an actuating member being configured to actuate at least a portion of the valve member from the closed position to the open position.

17. The medical connector of claim 9 further comprising providing a biasing member being configured to assert a restoring force on the valve member, the restoring force being configured to move the valve member longitudinally within the housing to the closed position, wherein the biasing member contacts a proximal half of the valve member.

18. The method of claim 9 further comprising providing the medical article.

\* \* \* \* \*