



US008142469B2

(12) **United States Patent**
Sosnowski et al.

(10) **Patent No.:** **US 8,142,469 B2**
(45) **Date of Patent:** **Mar. 27, 2012**

(54) **GASTRIC SPACE FILLER DEVICE, DELIVERY SYSTEM, AND RELATED METHODS**

(75) Inventors: **Stephen Alexander Sosnowski**, Vista, CA (US); **Tyler John Holschlag**, Carlsbad, CA (US); **Daniel Eugene Kincade**, Chula Vista, CA (US)

(73) Assignee: **ReShape Medical, Inc.**, San Clemente, CA (US)

(*) Notice: Subject to any disclaimer, the term of this patent is extended or adjusted under 35 U.S.C. 154(b) by 379 days.

(21) Appl. No.: **11/768,152**

(22) Filed: **Jun. 25, 2007**

(65) **Prior Publication Data**

US 2008/0319471 A1 Dec. 25, 2008

(51) **Int. Cl.**
A61M 29/00 (2006.01)

(52) **U.S. Cl.** **606/192**; 604/103.05

(58) **Field of Classification Search** 623/23.65, 623/23.67; 606/191-197, 37; 604/96.01, 604/509, 101.01, 103.05, 101-103

See application file for complete search history.

(56) **References Cited**

U.S. PATENT DOCUMENTS

2,493,326	A	1/1950	Trinder
4,133,315	A	1/1979	Berman et al.
4,246,893	A	1/1981	Berson
4,356,824	A	11/1982	Vazquez
4,416,267	A	11/1983	Garren et al.
4,485,805	A	12/1984	Foster, Jr.
4,598,699	A	7/1986	Garren et al.
4,694,827	A	9/1987	Weiner et al.

4,723,547	A	2/1988	Kullas et al.
4,899,747	A	2/1990	Garren et al.
5,084,061	A	1/1992	Gau et al.
5,123,840	A	6/1992	Nates
5,259,399	A	11/1993	Brown
5,263,934	A	11/1993	Haak
5,318,530	A	6/1994	Nelson, Jr.
5,334,187	A *	8/1994	Fischell et al. 604/102.02
5,431,173	A	7/1995	Chin et al.
5,496,271	A *	3/1996	Burton et al. 607/27
5,575,772	A	11/1996	Lennox
5,730,722	A	3/1998	Wilk
5,779,728	A *	7/1998	Lunsford et al. 606/190
5,857,991	A	1/1999	Grothoff et al.

(Continued)

FOREIGN PATENT DOCUMENTS

EP 0 457 456 5/1990

(Continued)

OTHER PUBLICATIONS

Wahlen CH et al. "The BioEnterics IntraGastric Balloon: How to use it" Obesity Surgery 2001;11:524-527.

(Continued)

Primary Examiner — Gary Jackson

Assistant Examiner — Katherine Dowe

(74) *Attorney, Agent, or Firm* — Perkins Coie LLP

(57) **ABSTRACT**

A gastric space filler device effective for reducing stomach volume comprises at least one inflatable space filler and a sleeve to prevent leakage out of the gastric space filler device. The gastric space filler device may be inflated with an insufflation fluid and with mineral oil, which further has the effect of reducing leakage. Delivery systems and methods are effective for inserting a gastric space filler device into a patient. The gastric space filler device may be provided with sheaths and methods for covering the gastric space filler device during delivery into a patient.

20 Claims, 7 Drawing Sheets

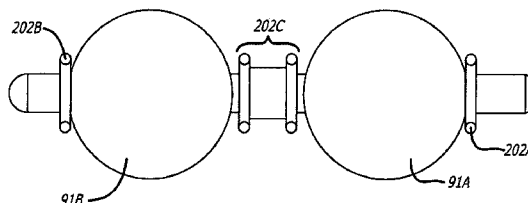
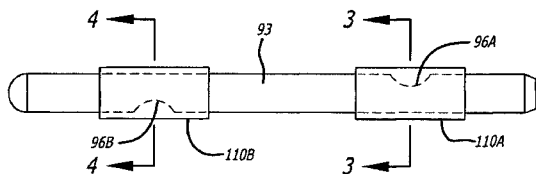

U.S. PATENT DOCUMENTS

5,938,669	A	8/1999	Klaiber et al.	
5,993,473	A *	11/1999	Chan et al.	606/192
6,149,621	A	11/2000	Makihara	
6,254,355	B1	7/2001	Gharib	
6,276,567	B1	8/2001	Diaz et al.	
6,280,411	B1	8/2001	Lennox	
6,423,058	B1	7/2002	Edwards et al.	
6,454,785	B2	9/2002	De Hoyos Garza	
6,535,764	B2	3/2003	Imran et al.	
6,547,788	B1	4/2003	Maguire et al.	
6,579,301	B1	6/2003	Bales et al.	
6,613,018	B2 *	9/2003	Bagga et al.	604/187
6,613,037	B2	9/2003	Khosravi et al.	
6,746,460	B2	6/2004	Gannoe et al.	
6,826,428	B1	11/2004	Chen et al.	
6,850,128	B2	2/2005	Park	
6,866,657	B2	3/2005	Shchervinsky	
6,890,300	B2	5/2005	Lloyd et al.	
6,923,754	B2 *	8/2005	Lubbock	600/3
6,939,299	B1	9/2005	Petersen et al.	
7,001,419	B2 *	2/2006	DiCaprio et al.	623/1.11
7,016,735	B2	3/2006	Imran et al.	
7,020,531	B1	3/2006	Colliou et al.	
7,033,373	B2	4/2006	de la Torre et al.	
7,056,305	B2	6/2006	Garza Alvarez	
7,076,305	B2	7/2006	Imran et al.	
7,131,945	B2	11/2006	Fink et al.	
7,483,746	B2	1/2009	Lee et al.	
2001/0037127	A1	11/2001	De Hoyos Garza	
2002/0055757	A1	5/2002	Torre	
2002/0161388	A1	10/2002	Samuels et al.	
2002/0173804	A1 *	11/2002	Rousseau	606/151
2003/0114878	A1 *	6/2003	Diederich et al.	606/192
2003/0171768	A1	9/2003	McGhan	
2003/0187390	A1	10/2003	Bates et al.	
2004/0044354	A1	3/2004	Gannoe et al.	
2004/0059289	A1	3/2004	Garza Alvarez	
2004/0087902	A1	5/2004	Richter	
2004/0116897	A1	6/2004	Aboul- Hosn	
2004/0186502	A1	9/2004	Sampson et al.	
2004/0254600	A1 *	12/2004	Zarbatany et al.	606/194
2005/0038415	A1	2/2005	Rohr et al.	
2005/0075624	A1	4/2005	Miesel	
2005/0085792	A1 *	4/2005	Gershowitz	604/509
2005/0119674	A1	6/2005	Gingras	
2005/0143784	A1	6/2005	Imran	
2005/0159769	A1	7/2005	Alverdy	
2005/0177103	A1	8/2005	Hunter et al.	
2005/0192615	A1	9/2005	Torre et al.	
2005/0267595	A1	12/2005	Chen et al.	
2005/0267596	A1	12/2005	Chen et al.	
2006/0058829	A1	3/2006	Sampson et al.	
2007/0016262	A1	1/2007	Gross et al.	
2007/0100367	A1	5/2007	Quijano	
2007/0100368	A1	5/2007	Quijano	
2007/0100369	A1 *	5/2007	Cragg et al.	606/192
2007/0142770	A1	6/2007	Rioux et al.	
2007/0149994	A1	6/2007	Sosnowski	
2007/0173881	A1 *	7/2007	Birk et al.	606/192
2007/0250020	A1 *	10/2007	Kim et al.	604/264
2008/0082056	A1 *	4/2008	Mauch et al.	604/263
2008/0097513	A1	4/2008	Kaji et al.	
2008/0119729	A1	5/2008	Copa et al.	
2008/0172079	A1	7/2008	Birk	
2008/0208241	A1	8/2008	Weiner et al.	
2008/0233167	A1	9/2008	Li et al.	
2008/0243071	A1	10/2008	Quijano	
2008/0243166	A1	10/2008	Paganon et al.	
2009/0048624	A1	2/2009	Alverdy	
2010/0130998	A1	5/2010	Alverdy	

FOREIGN PATENT DOCUMENTS

EP	0 485 903	8/1991
EP	0457456 A1	11/1991
EP	0485903 A2	5/1992

FR	2862525 A1	5/2005
GB	2 139 902 A	11/1984
GB	2139902 A	11/1984
WO	WO 2006035446	4/2006
WO	WO-2006035446 A2	4/2006
WO	WO 2006/128978	12/2006
WO	WO-2006/128978 A1	12/2006
WO	WO-2009112786 A2	9/2009
WO	WO-2010115161 A2	10/2010
WO	WO-2011011629 A2	1/2011
WO	WO-2011011741 A2	1/2011
WO	WO-2011011743 A2	1/2011
WO	WO-2011038270 A2	3/2011

OTHER PUBLICATIONS

Patient information "Living with the BIB" by INAMED Health (2004).

International Search Report; International Application No. PCT/US2008/058677, Applicant: ReShape Medical et al., Mailing Date Aug. 21, 2008, 12 pages.

International Search Report; International Application No. PCT/US2006/042710, Applicant: Abdominus, Inc. et al., Mailing Date Mar. 15, 2007, 9 pages.

International Search Report; International Application No. PCT/US2006/048647, Applicant: Abdominus, Inc. et al., Mailing Date May 22, 2007, 12 pages.

International Search Report; International Application No. PCT/US2008/068058, Applicant: ReShape Medical, Inc. et al, Mailing Date Nov. 19, 2008, 11 pages.

International Search Report; International Application No. PCT/US2006/042711, Applicant: Abdominus, Inc. et al, Mailing Date Mar. 16, 2007, 9 pages.

Supplementary European Search Report for EP 03726447.0, mailed Mar. 1, 2006.

International Search Report; International Application No. PCT/US2003/012782, Applicant: Applied Medical Resources Corporation, Mailing Date Oct. 28, 2003, 7 pages.

International Search Report; International Application No. PCT/US2006/042336, Applicant: Abdominus, Inc., Mailing Date Mar. 14, 2007, 9 pages.

International Search Report; International Application No. PCT/US2010/029865, Applicant: ReShape Medical, Inc., Mailing Date Jan. 5, 2011, 9 pages.

Final Office Action; U.S. Appl. No. 11/694,536, Mailing Date Mar. 11, 2011, 13 pages.

International Search Report; International Application No. PCT/US2011/024082, Applicant: ReShape Medical, Inc., Mailing Date Apr. 6, 2011, 10 pages.

International Search Report; International Application No. PCT/US2011/024077; Applicant: ReShape Medical, Inc., Mailing Date Apr. 6, 2011, 12 pages.

International Search Report; International Application No. PCT/US2010/042948; Applicant: ReShape Medical, Inc., Mailing Date Apr. 1, 2011, 11 pages.

International Search Report; International Application No. PCT/US2010/043136; Applicant: ReShape Medical, Inc., Mailing Date Apr. 12, 2011, 9 pages.

International Search Report; International Application No. PCT/US2010/043134; Applicant: ReShape Medical, Inc., Mailing Date Apr. 27, 2011, 12 pages.

International Search Report; International Application No. PCT/US2011/0426233; Applicant: ReShape Medical, Inc., Mailing Date Apr. 26, 2011, 9 pages.

"ReShape Inflatable Gastric Ballon Going on Trial as Weight Loss Option," MedGadget: Internet Journal of Emerging Medical Technologies. Feb. 4, 2010. (5 pages).

* cited by examiner

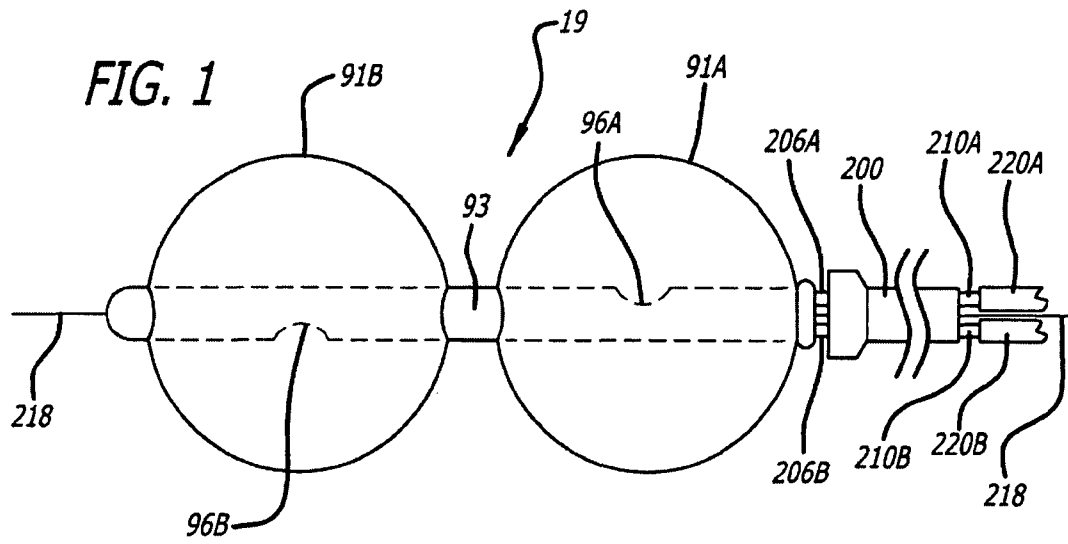

FIG. 2A

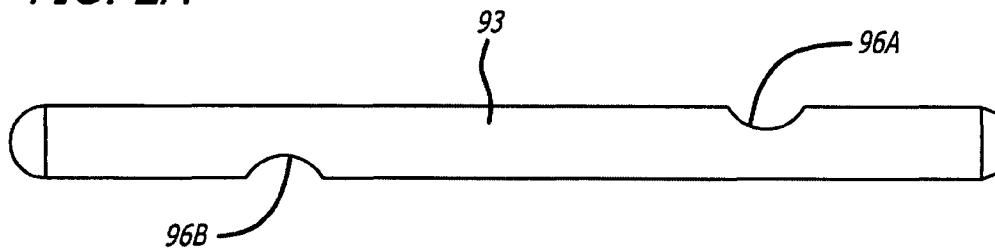
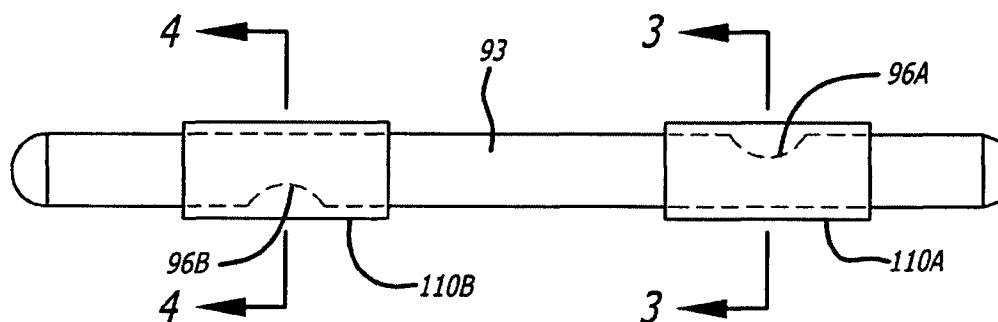

FIG. 2B



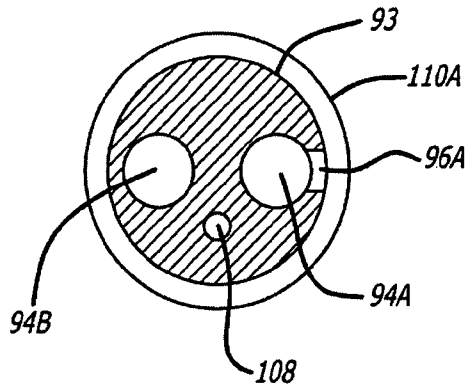

FIG. 3

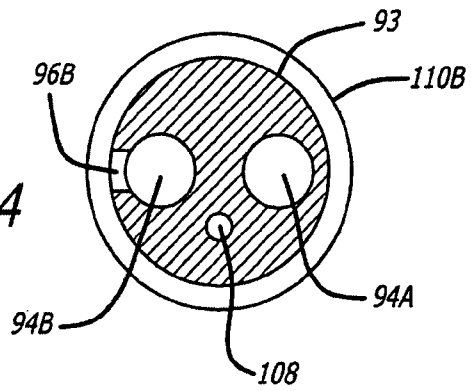

FIG. 4

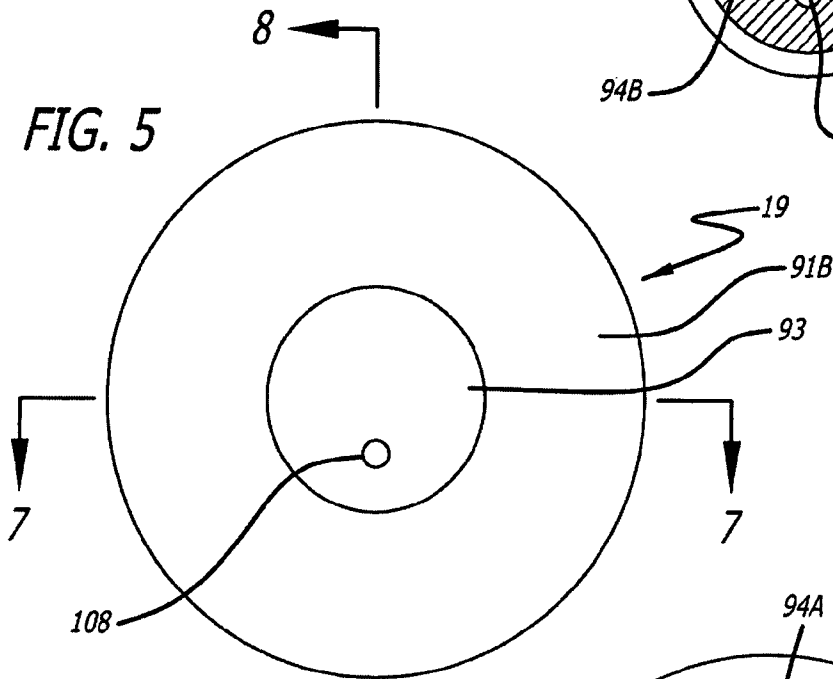

FIG. 5

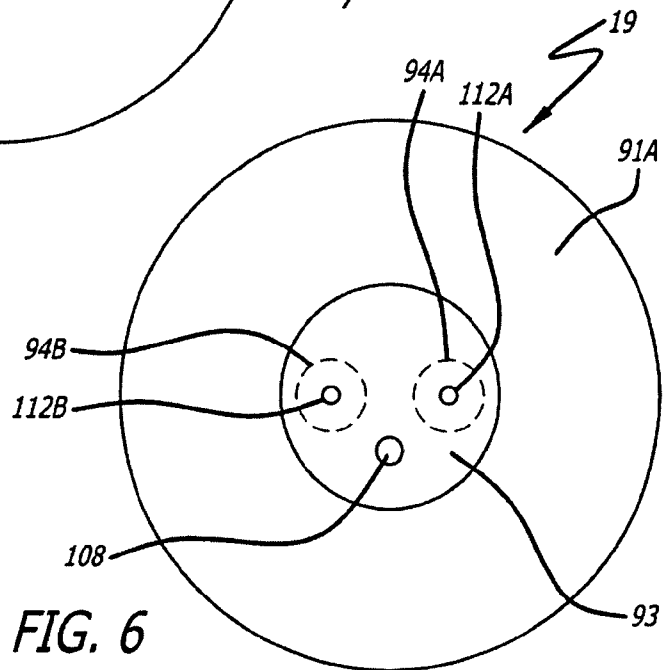

FIG. 6

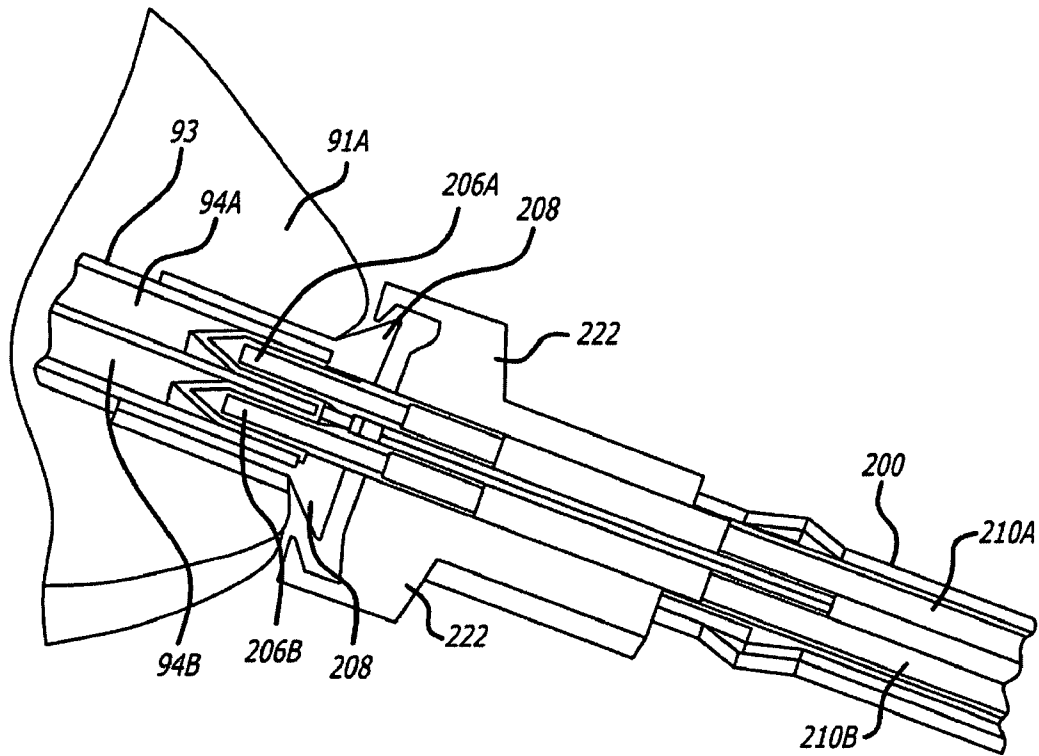

FIG. 7

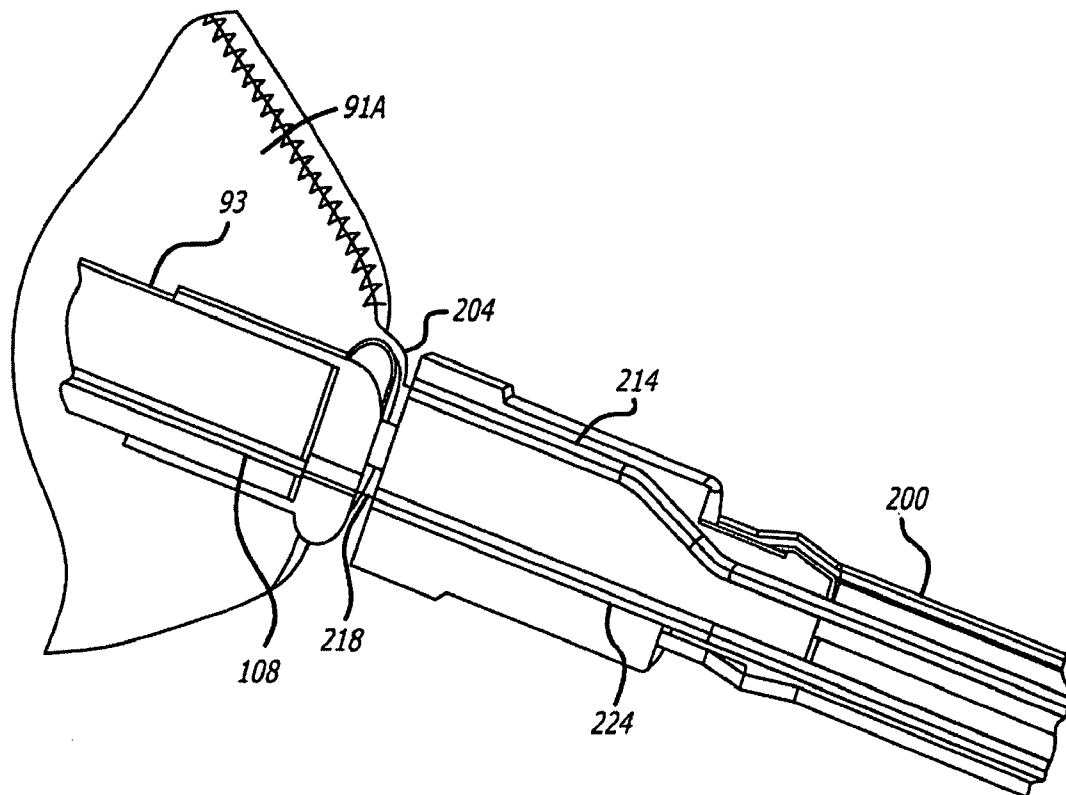

FIG. 8

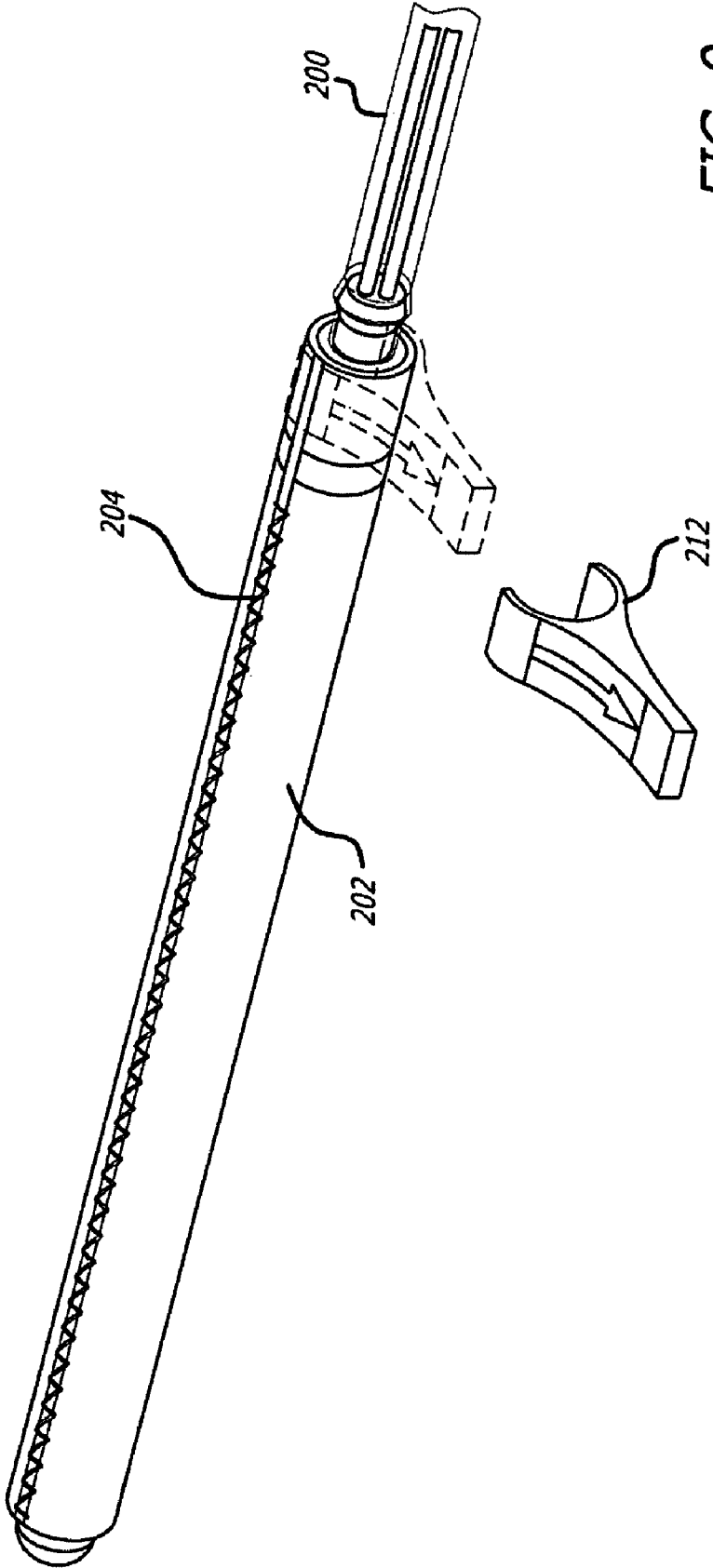

FIG. 9

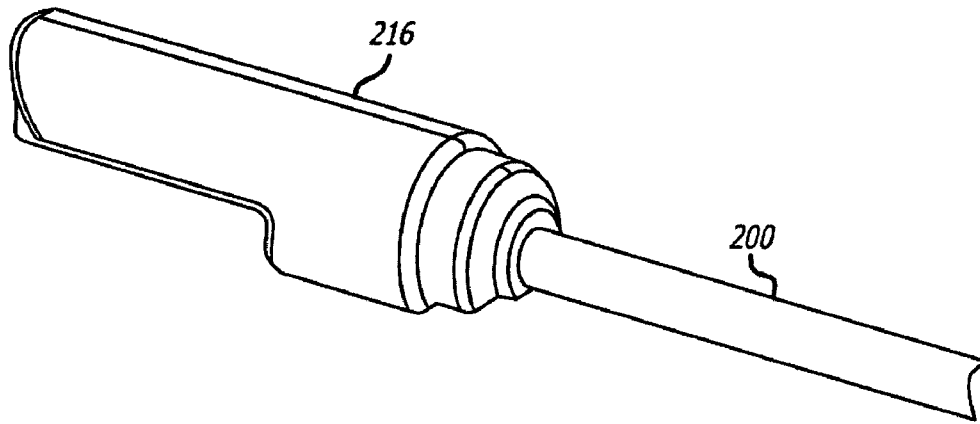

FIG. 10A

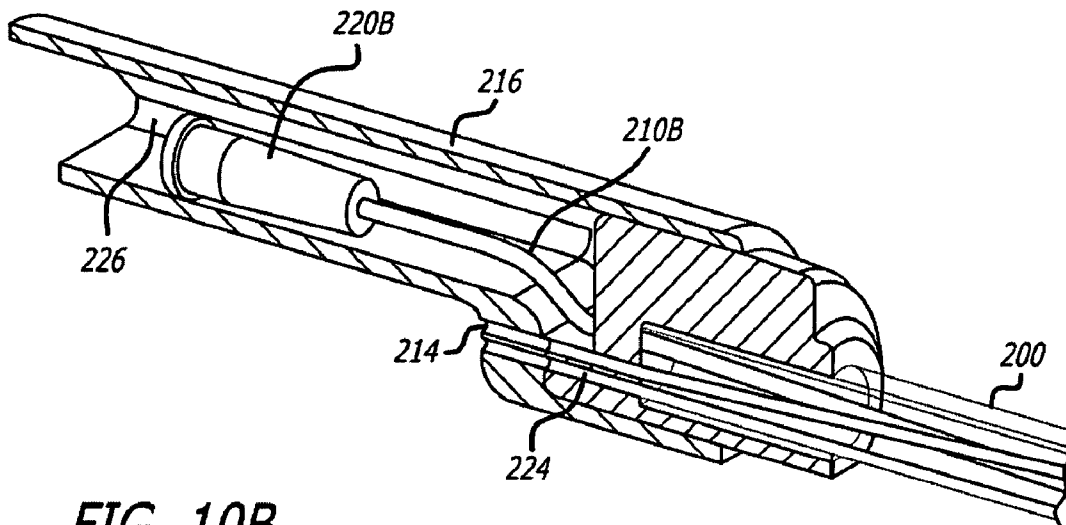

FIG. 10B

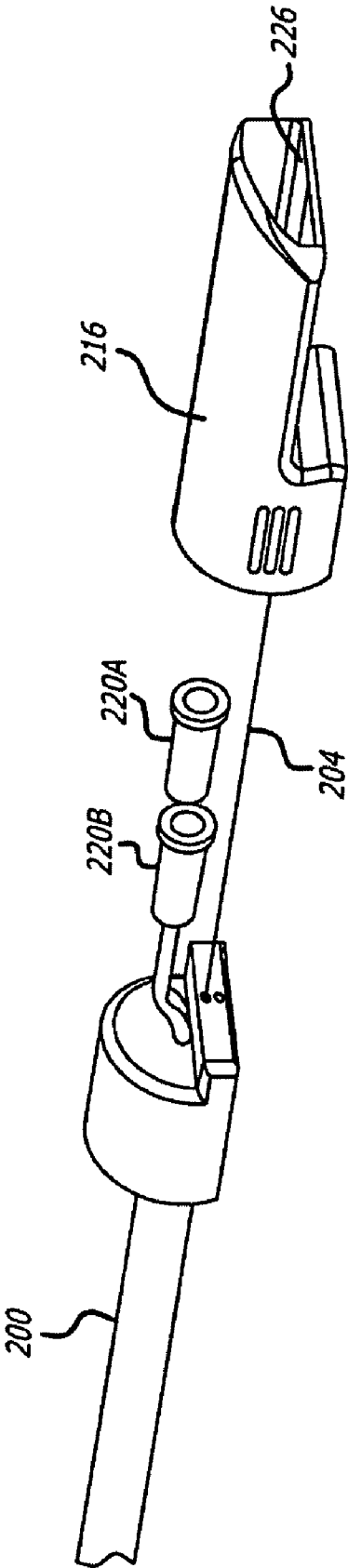

FIG. 10C

FIG. 11A

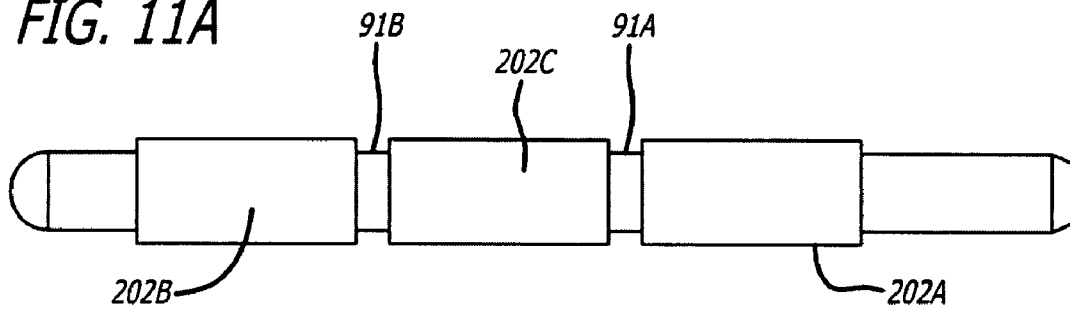

FIG. 11B

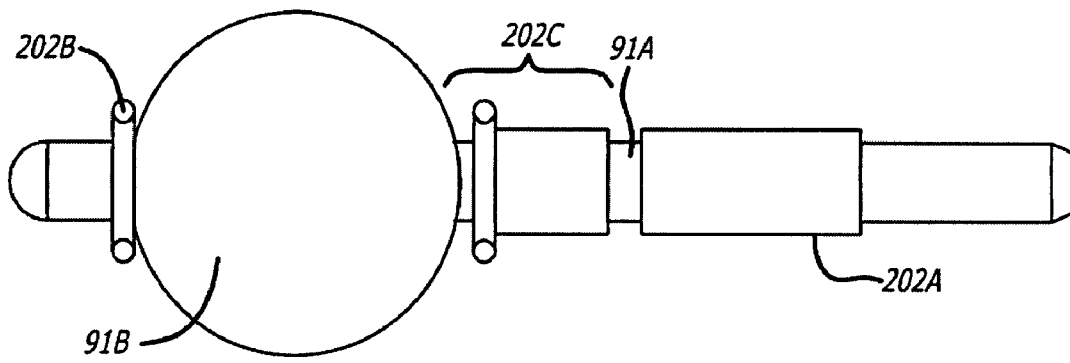
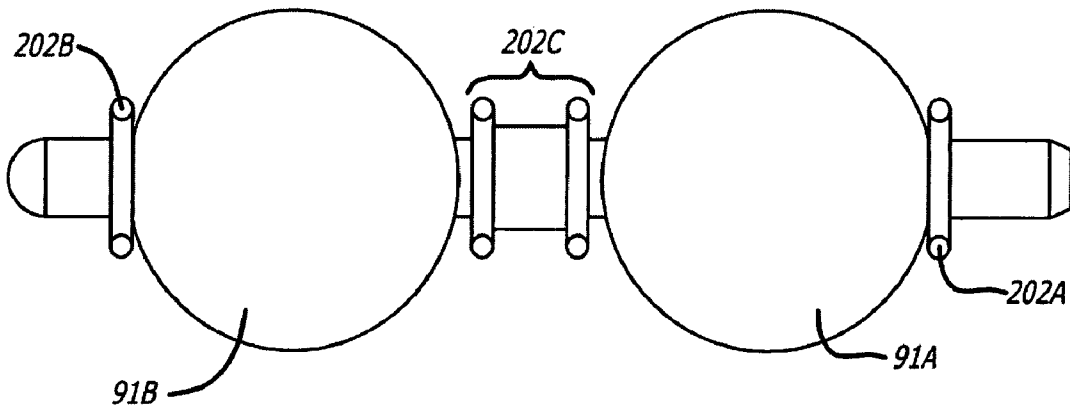

FIG. 11C



GASTRIC SPACE FILLER DEVICE, DELIVERY SYSTEM, AND RELATED METHODS

RELATED APPLICATIONS

This following commonly-assigned applications are incorporated herein by reference in their entireties: (a) U.S. patent application Ser. No. 11/694,536, filed Mar. 30, 2007; (b) Int'l App. No. PCT/US06/42336, filed Oct. 31, 2006, (c) Int'l App. No. PCT/US06/42711, filed Oct. 31, 2006, (d) Int'l App. No. PCT/US06/42710, filed Oct. 31, 2006, and (e) Int'l App. No. PCT/US06/48647, filed Dec. 20, 2006.

BACKGROUND

1. Field

This disclosure relates to implantable weight control devices. More particularly, this disclosure relates to a gastric space filler device which is retrievably implantable in a patient, an improved device and method for delivery of a gastric space filler device, and a method and device for retaining fluid in a gastric space filler device, among other things.

2. General Background

Gastric space fillers used for achieving loss of weight in extremely obese persons have been known in the art. Some gastric space fillers utilized for this purpose function on the principle that an empty bag or space filler is placed into the stomach through the esophagus. Thereafter, the bag or space filler is fully or partially filled with a suitable insufflation fluid, such as saline solution, through a filler tube or catheter which is inserted into the stomach through the mouth or the nose. The space filler occupies space in the stomach thereby leaving less room available for food and creating a feeling of satiety for the obese person. Clinical experience has shown that, for many obese patients, reducing the size of the gastric compartment with gastric space fillers significantly helps to control appetite and accomplish weight loss. The present disclosure is directed to a device which non-operatively reduces the size of the gastric compartment and which is easily removed. Artisans shall readily appreciate that emergency operative morbidity rates and co-morbidity statistics relating to such devices which have migrated beyond the stomach underscore the need for an effective medical device that can be removed.

SUMMARY

According to features of the present disclosure, a gastric space filler device and methods effective for reducing stomach volume are disclosed. A gastric space filler comprising at least one inflatable space filler and a sleeve to prevent leakage out of the gastric space filler device is disclosed. The gastric space filler device may be inflated with an insufflation fluid and with mineral oil, which further has the effect of reducing leakage. Delivery systems and methods for inserting a gastric space filler device into a patient are also disclosed. Sheaths and methods for covering a gastric space filler device during delivery into a patient are also disclosed.

According to embodiments of the instant teachings, there is disclosed a gastric space filler device comprising a space filler, an opening to inflate the space filler, and a sleeve that is configured to receive mineral oil between the sleeve and the opening. According to at least one embodiment, the sleeve is disposed between the opening and the outer periphery of the space filler. According to at least one embodiment, the sleeve allows fluid to enter the space filler during inflation, but does

not allow fluid to exit the space filler when mineral oil is received between the sleeve and the opening.

According to embodiments of the instant teachings, there is disclosed a gastric space filler device comprising a space filler and a sheath, wherein the sheath at least partially covers the space filler. According to at least one embodiment, the sheath is secured around the space filler with a stitch that can be released by pulling on the stitch. According to at least one embodiment, the sheath automatically uncovers the space filler as the space filler is inflated.

According to embodiments of the instant teachings, there is disclosed a delivery system comprising a delivery lumen, a barb configured for coupling with an infusing lumen of a gastric space filler device, and a docking clip configured for securely attaching the delivery system to the gastric space filler device. According to at least one embodiment, the delivery system contains a handle that, when removed from the infusing lumen, pulls a stitch to release a space filler and simultaneously uncovers a luer for infusing a fluid into the gastric space filler device.

According to embodiments of the instant teachings, there is disclosed a method for treating obesity challenged patients comprising providing a gastric space filler device comprising a space filler, an opening to inflate the space filler with a fluid, and a sleeve disposed between the opening and an outer periphery of the space filler; allowing the fluid to enter the space filler through the opening; and preventing the fluid from exiting the space filler through the opening.

According to embodiments of the instant teachings, there is disclosed a method for emplacing a gastric space filler device in a patient comprising providing a delivery system attached to a gastric space filler device comprising a space filler; covering at least part of the space filler with a sheath; and delivering the delivery system and the gastric space filler device through an esophagus into a stomach of a patient.

DRAWINGS

The above-mentioned features and objects of the present disclosure will become more apparent with reference to the following description taken in conjunction with the accompanying drawings wherein like reference numerals denote like elements and in which:

FIG. 1 shows an embodiment of a gastric space filler device and delivery system;

FIG. 2A shows an embodiment of an infusing member without proximal sleeve or distal sleeve;

FIG. 2B shows an embodiment of an infusing member with a proximal sleeve and a distal sleeve;

FIG. 3 shows a cross-sectional view of an embodiment of an infusing member, a proximal sleeve, and a proximal opening;

FIG. 4 shows a cross-sectional view of an embodiment of an infusing member, a distal sleeve, and a distal opening;

FIG. 5 shows a rear view of an embodiment of a gastric space filler device containing a distal space filler;

FIG. 6 shows a front view of an embodiment of a gastric space filler device containing a proximal space filler;

FIG. 7 shows a cross-sectional view of an embodiment of a gastric space filler device and a delivery system containing a proximal delivery lumen and a distal delivery lumen;

FIG. 8 shows a cross-sectional view of an embodiment of a gastric space filler device and a delivery system containing a stitch channel and a delivery guide wire channel;

FIG. 9 shows an embodiment of a gastric space filler device and a delivery system containing a sheath, a stitch, and a sheath release clip;

FIG. 10A shows an embodiment of a delivery system containing a handle;

FIG. 10B shows a cross-sectional view of an embodiment of a delivery system containing a handle;

FIG. 10C shows an embodiment of a delivery system and a handle detached from delivery system;

FIG. 11A shows an embodiment of a gastric space filler device and sheaths wherein a proximal space filler and a distal space filler are deflated;

FIG. 11B shows an embodiment of a gastric space filler device, wherein a distal space filler is inflated;

FIG. 11C shows an embodiment of a gastric space filler device, wherein a proximal space filler is inflated.

DETAILED DESCRIPTION

According to an embodiment as schematically depicted in FIG. 1, gastric space filler device 19 comprises proximal space filler 91A, distal space filler 91B, and infusing member 93. Proximal space filler 91A is filled with an insufflation fluid through proximal opening 96A of infusing member 93, and distal space filler 91B is filled with fluid from distal opening 96B of infusing member 93. Delivery system 200 infuses and expands gastric space filler device 19.

According to an illustrative embodiment, proximal space filler 91A and distal space filler 91B are spaced apart and secured to each other by infusing member 93. According to an illustrative embodiment, the distance between the two space fillers is between at least about 10 to approximately 40 mm. The overall axial length of gastric space filler device 19 is between about 100 and about 300 mm. According to an illustrative embodiment, infusing member 93 may be made of semi-flexible or flexible material. The semi-flexible material may be selected from space filler-compatible polymer, such as, polyethylene, polystyrene, polyurethane, silicone, fluoropolymer, and co-polymers thereof.

According to an illustrative embodiment, the longitudinal length of proximal space filler 91A is between about 70 and about 80 mm, preferably about 75 mm. Proximal space filler 91A may be expanded to a space volume of between about 100 and about 600 cc. In an embodiment, the longitudinal length of distal space filler 91B is between about 60 and about 70 mm, preferably about 65 mm.

Distal space filler 91B may be expanded to a space volume of between about 100 and about 400 cc. According to a further embodiment, a radial diameter of proximal space filler 91A may be expanded to a diameter between about 40 and about 60 mm, and a radial diameter of distal space filler 91B may be expanded to a diameter between about 20 and about 40 mm. According to an illustrative embodiment, proximal space filler 91A is substantially larger than distal space filler 91B in gastric space filler device 19 to take the advantage of the restricted space at the entrance region of the stomach and to create a better feeling of satiety for the patient. According to an illustrative embodiment, the thickness of proximal space filler 91A and distal space filler 91B is between about 0.2 and about 1.0 mm, effectively between about 0.3 to about 0.5 mm.

According to an embodiment as depicted in FIG. 2B, infusing member 93 contains proximal sleeve 110A that wraps around infusing member 93 and covers proximal opening 96A, which connects proximal space filler 91A to proximal infusing lumen 94A. Infusing member 93 also contains distal sleeve 110B that wraps around infusing member 93 and covers distal opening 96B, which connects distal space filler 91B to distal infusing lumen 94B.

According to an embodiment as depicted in FIG. 3, proximal infusing lumen 94A of infusing member 93 has proximal

opening 96A that provides fluid communication between infusing lumen 94A and proximal space filler 91A. According to an embodiment as depicted in FIG. 4, distal infusing lumen 94B of infusing member 93 has distal opening 96B that provides fluid communication between distal infusing lumen 94B and distal space filler 91B. Proximal space filler 91A and proximal infusing lumen 94A are not in fluid communication with either distal space filler 91B or distal infusing lumen 94B. According to an illustrative embodiment, infusing member 93 has an inner diameter of between about 1 and about 6 mm. According to an illustrative embodiment, proximal infusing lumen 94A is substantially larger than distal infusing lumen 94B.

According to an illustrative embodiment, proximal opening 96A connects proximal space filler 91A to proximal infusing lumen 94A. According to an illustrative embodiment, proximal sleeve 110A wraps around infusing member 93 and covers proximal opening 96A. Proximal sleeve 110A may be disposed between proximal opening 96A and outer periphery of proximal space filler 91A.

As proximal space filler 91A is being inflated, proximal sleeve 110A allows an insufflation fluid to enter proximal space filler 91A from proximal infusing lumen 94A through proximal opening 96A. According to an illustrative embodiment, proximal sleeve 110A allows an insufflation fluid to enter proximal space filler 91A by moving at least part of proximal sleeve 110A away from proximal opening 96A. According to an illustrative embodiment, at least part of proximal sleeve 110A is moved away from proximal opening 96A as a result of higher pressure outside proximal space filler 91A in relation to pressure inside proximal space filler 91A.

According to an illustrative embodiment, after proximal space filler 91A is inflated, proximal sleeve 110A is pressed against proximal opening 96A; thus proximal sleeve 110A does not allow fluid to exit proximal space filler 91A through proximal opening 96A. According to an illustrative embodiment, higher pressure inside proximal space filler 91A, relative to pressure outside proximal space filler 91A, presses proximal sleeve 110A against proximal opening 96A.

According to another embodiment, proximal sleeve 110A is not wrapped around infusing member 93, but is attached to infusing member 93 and is configured to move at least partially away from proximal opening 96A while proximal space filler 91A is being inflated and is also configured to block proximal opening 96A after proximal space filler 91A has been inflated.

According to an embodiment as depicted in FIG. 4, distal sleeve 110B covers distal opening 96B. Distal sleeve 110B allows inflation of distal space filler 91B through distal opening 96B and prevents deflation of distal space filler 91B through distal opening 96B while distal space filler 91B is inflated. Appropriate materials for proximal sleeve 110A or distal sleeve 110B include any elastomeric material, such as silicone.

According to an illustrative embodiment, an insufflation fluid, such as a saline solution, is used to inflate proximal space filler 91A or distal space filler 91B to a desired volume effective to fill the desired portion of a stomach of a patient and create the desired feeling of satiety. When proximal space filler 91A is inflated to this point, mineral oil is infused through proximal opening 96A and received between proximal sleeve 110A and proximal opening 96A. The mineral oil displaces the insufflation fluid in the area between proximal sleeve 110A and proximal opening 96A. Mineral oil between proximal sleeve 110A and proximal opening 96A has the effect of decreasing leakage of the insufflation fluid out of

5

proximal space filler **91A** through proximal opening **96A**. According to an illustrative embodiment, an effective amount of mineral oil is the amount of mineral oil with volume equal to the volume of the insufflation fluid to be displaced by the mineral oil. According to an illustrative embodiment, mineral oil is received between distal sleeve **110B** and distal opening **96B**. Unexpectedly, this teaching substantially improves leakage and has yet to have been disclosed.

According to an embodiment as depicted in FIG. 6, proximal infusing lumen **94A** contains proximal gate **112A**, and distal infusing lumen **94B** contains distal gate **112B**, disposed at proximal end of infusing member **93**. Proximal gate **112A** prevents at least some of any fluid from traveling into or out of proximal infusing lumen **94A** until proximal barb **206A** is inserted through proximal gate **112A** and into proximal infusing lumen **94A**. Similarly, distal gate **112B** prevents at least some of any fluid from traveling into or out of distal infusing lumen **94B** until distal barb **206B** is inserted through distal gate **112B** and into distal infusing lumen **94B**. Proximal gate **112A** or distal gate **112B** may be made of a flexible material that substantially covers proximal infusing lumen **94A** or distal infusing lumen **94B** and can be manipulated to allow insertion of proximal barb **206A** or distal barb **206B**.

According to an embodiment as depicted in FIG. 7, after gastric space filler device **19** is delivered to the stomach of a patient, delivery system **200** is inserted through the mouth to securely couple with proximal end of gastric space filler device **19**. According to another embodiment, delivery system **200** is securely coupled to gastric space filler device **19** before gastric space filler device **19** and delivery system **200** are delivered to the stomach of a patient. According to an illustrative embodiment, delivery system **200** may be coupled to gastric space filler device **19** by docking clip **222** of delivery system **200**, which is configured to securely attach to docking notch **208** of gastric space filler device **19**.

According to an illustrative embodiment, delivery system **200** contains proximal barb **206A** and distal barb **206B**. Proximal barb **206A** is in fluid communication with proximal delivery lumen **210A**, and distal barb **206B** is in fluid communication with distal delivery lumen **210B**. When delivery system **200** is securely coupled with proximal end of gastric space filler device **19**, proximal barb **206A** and distal barb **206B** are at least partially inserted into proximal infusing lumen **94A** and distal infusing lumen **94B**, respectively.

Proximal space filler **91A** may be inflated by delivering an insufflation fluid into proximal delivery lumen **210A**, thereby delivering insufflation fluid through proximal barb **206A** and into proximal infusing lumen **94A**. Similarly, distal space filler **91B** may be inflated by delivering an insufflation fluid into distal delivery lumen **210B**, thereby delivering insufflation fluid through distal barb **206B** and into the distal infusing lumen **94B**.

According to an embodiment as depicted in FIG. 8, gastric space filler device **19** contains filler guide wire channel **108**, and delivery system **200** contains delivery guide wire channel **224**. According to an illustrative embodiment, guide wire **218** is laid along a path to be traveled by gastric space filler device **19** or delivery system **200**. Guide wire **218** is then threaded through at least one of guide wire channel **108** of gastric space filler device **19** and delivery guide wire channel **224** of delivery system **200**. Once threaded, gastric space filler device **19** or delivery system **200** may travel along guide wire **218**.

According to an embodiment as depicted in FIG. 9, sheath **202** at least partially covers proximal space filler **91A** and distal space filler **91B** before or during insertion through an esophagus of a patient. Sheath **202** may be made from flexible or semi-flexible materials, including mesh fabric and sili-

6

cone. According to an illustrative embodiment, sheath **202** is secured to gastric space filler device **19** by stitch **204**. Various stitching patterns are known in the art. Stitch **204** may comprise an easily releasable stitching pattern, such as one that may be released by pulling on one end of stitch **204**. When proximal space filler **91A** or distal space filler **91B** is ready to inflate, stitch **204** is removed.

According to an illustrative embodiment, at least part of stitch **204** is secured by sheath release clip **212** until gastric space filler device **19** is ready to be inserted into patient. Sheath release clip **212**, while engaged, secures at least part of stitch **204**, such that stitch **204** may not be released. When sheath release clip **212** is removed, stitch **204** is capable of being released.

According to an illustrative embodiment, at least part of stitch **204** is located inside stitch channel **214** of delivery system **200**. This allows stitch **204** to be pulled away from gastric space filler device **19** without additional instruments. Where stitch **204** is released from sheath **202** by pulling on an end of stitch **204**, stitch **204** may be released by pulling stitch **204** through stitch channel **214**.

According to an embodiment as depicted in FIG. 10A, delivery system **200** may contain handle **216**, which may be removably attached to delivery system **200**. According to an embodiment as depicted in FIG. 10B, handle **216** contains inner compartment **226**. Proximal luer **220A** and distal luer **220B** may be contained within inner compartment **226** while handle is attached to delivery system **200**. While handle **216** is attached to delivery system **200**, proximal luer **220A** and distal luer **220B** may not be accessed to infuse fluid into proximal space filler **91A** or distal space filler **91B**.

According to an embodiment as depicted in FIG. 10C, stitch **204** may be attached to handle **216**, such that when handle **216** is removed from delivery system **200**, stitch **204** is pulled away from sheath **202**, thereby releasing sheath **202** from covering proximal space filler **91A** or distal space filler **91B**. Likewise, removal of handle **216** exposes proximal luer **220A** and distal luer **220B**, such that proximal space filler **91A** and distal space filler **91B** can be infused only when handle **216** is removed. In this embodiment, proximal space filler **91A** and distal space filler **91B** cannot be inflated until sheath **202** is released.

According to an embodiment as depicted in FIG. 11A, FIG. 11B, and FIG. 11C, gastric space filler device **19** is at least partially covered by three sheaths: proximal sheath **202A**, central sheath **202C**, and distal sheath **202B**. Distal sheath **202B** at least partially covers distal portion of distal space filler **91B**, central sheath **202C** at least partially covers proximal portion of distal space filler **91B** and distal portion of proximal space filler **91A**, and proximal sheath **202A** at least partially covers proximal portion of proximal space filler **91A**.

As distal space filler **91B** is inflated, distal sheath **202B** is rolled onto itself toward distal end of gastric space filler device **19** and distal portion of central sheath **202C** is rolled onto itself toward center of gastric space filler device **19**. As proximal space filler **91A** is inflated, proximal sheath **202A** is rolled onto itself toward proximal end of gastric space filler device **19**, and proximal portion of central sheath **202C** is rolled onto itself toward center of gastric space filler device **19**. In an illustrative embodiment, as proximal space filler **91A** is inflated, proximal sheath **202A** is rolled onto itself toward delivery system **200** attached to proximal end of gastric space filler device **19**, such that when proximal space filler **91A** is inflated, proximal sheath **202A** is rolled onto delivery

system **200** and when delivery system **200** is detached and removed, proximal sheath **202A** is removed with delivery system **200**.

In an illustrative embodiment, gastric spacer filler device **19** is at least partially covered by two sheaths: proximal sheath **202A** and distal sheath **202B**. Distal sheath **202B** at least partially covers distal space filler **91B** until distal space filler **91B** is inflated, which causes distal sheath **202B** to be rolled onto itself, either toward distal end of gastric space filler device **19** or toward center of gastric space filler device **19**. Similarly, proximal sheath **202A** at least partially covers proximal space filler **91A** until proximal space filler **91A** is inflated, which causes proximal sheath **202A** to be rolled onto itself, either toward proximal end of gastric space filler device **19** or toward the center of gastric space filler device **19**.

In an illustrative embodiment, gastric space filler device **19** is at least partially covered by a single sheath: central sheath **202C**. Central sheath **202C** at least partially covers each of proximal space filler **91A** and distal space filler **91B**. As distal space filler **91B** is inflated, central sheath **202C** is rolled onto itself from proximal end of gastric space filler device **19** toward center of gastric space filler device **19** until central sheath **202C** no longer covers distal space filler **91B**. As proximal space filler **91A** is inflated, central sheath **202C** is rolled onto itself from proximal end of gastric space filler device **19** toward center of gastric space filler device **19** until central sheath **202C** no longer covers proximal space filler **91A**. Alternatively, as proximal space filler **91A** is inflated, central sheath **202C** may be rolled from center of gastric space filler device **19** toward proximal end of gastric space filler device **19**.

While the apparatus and method have been described in terms of what are presently considered to be the most practical embodiments, it is to be understood that the disclosure need not be limited to the disclosed embodiments. It is intended to cover various modifications and similar arrangements included within the spirit and scope of the claims, the scope of which should be accorded the broadest interpretation so as to encompass all such modifications and similar structures. The present disclosure includes any and all embodiments of the following claims.

The invention claimed is:

1. A gastric space filler device, comprising:

a space filler including an opening;

a sleeve;

an infusing member coupled with the space filler and extending from outside the space filler to within an interior portion of the space filler,

wherein the infusing member comprises an infusing lumen in fluid communication with the opening,

wherein the opening is disposed on a portion of the infusing member that is within the interior portion of the space filler,

wherein the opening provides fluid communication between the infusing lumen and the interior portion of the space filler, and

wherein the sleeve covers the opening on a side thereof facing the interior portion of the space filler;

an inflation fluid within the interior portion of the space filler, wherein the inflation fluid is delivered from the infusing lumen through the opening; and

an oil delivered from the infusing lumen through the opening and received between the sleeve and the opening, wherein the oil is a material other than the inflation fluid, wherein the oil is configured to inhibit leakage of the inflation fluid out of the space filler.

2. The gastric space filler device of claim **1**, wherein the sleeve is wrapped around the infusing member.

3. The gastric space filler device of claim **1**, wherein the sleeve allows the inflation fluid to enter the space filler during inflation of the space filler.

4. The gastric space filler device of claim **1**, wherein the infusing member is comprised of a flexible material.

5. The gastric space filler device of claim **1**, wherein the infusing lumen comprises a gate configured to reduce passage of a fluid until a barb is inserted into the infusing lumen.

6. The gastric space filler device of claim **1**, further comprising a sheath, wherein the sheath at least partially covers the space filler.

7. The gastric space filler device of claim **6**, wherein the sheath is secured around the space filler with a stitch.

8. The gastric space filler device of claim **7**, wherein the stitch sheath is configured to be released by pulling the stitch.

9. The gastric space filler device of claim **8**, further comprising a sheath release clip, wherein the sheath release clip is configured to prevent the stitch from being released while the sheath release clip is engaged on the gastric space filler device, and further wherein the sheath release clip is configured to allow the stitch to be released when the sheath release clip is removed from the gastric space filler device.

10. The gastric space filler device of claim **8**, further comprising a delivery system, wherein the delivery system comprises:

a delivery lumen configured to deliver the inflation fluid to the space filler;

a luer connected to the delivery lumen; and

a handle removably attached to the delivery lumen, wherein the handle comprises an inner compartment and the luer is disposed inside at least a portion of the inner compartment of the handle while the handle is removably attached to the delivery lumen, and wherein the luer is exposed when the handle is removed, and further wherein the stitch is attached to the handle such that the stitch is pulled when the handle is removed.

11. The gastric space filler device of claim **6**, wherein the sheath automatically uncovers the space filler as the space filler is inflated, and wherein the sheath remains in contact with the space filler after uncovering.

12. The gastric space filler of claim **1**, wherein the oil comprises a petroleum based oil.

13. The gastric space filler of claim **1**, wherein the oil comprises mineral oil.

14. A method for treating obesity challenged patients the method comprising:

delivering a gastric space filler device to a stomach, wherein the gastric space filler device comprises a space filler including an opening, the opening being disposed on an infusing member extending from outside the space filler to within the space filler, and a sleeve covering the opening on a side thereof facing an interior portion of the space filler;

inflating the interior portion of the space filler with an insufflation fluid from the infusing member through the opening; and

providing mineral oil from the infusing member through the opening to between the sleeve and the opening of the infusing member, whereby the mineral oil displaces the insufflation fluid from between the sleeve and the opening of the infusing member to inhibit leakage of the insufflation fluid out of the space filler.

15. The method of claim **14**, wherein inflating the interior portion of the space filler comprises moving at least part of the sleeve away from the opening.

9

16. The method of claim 14, wherein the sleeve is wrapped around the infusing member.

17. The method of claim 14, wherein the sleeve is configured to allow passage of the insufflation fluid through the opening when pressure outside the space filler is greater than pressure inside the space filler, and wherein the sleeve is further configured to not allow the insufflation fluid to exit through the opening when pressure inside the space filler is greater than pressure outside the space filler.

18. A method for emplacing a gastric space filler device in a patient, the method comprising:

delivering a gastric space filler device through an esophagus into a stomach of a patient, wherein the gastric space filler device comprises a proximal space filler and a distal space filler on an infusing member, a proximal sheath at least partially covering a proximal portion of the proximal space filler, and a central sheath at least partially covering a distal portion of the proximal space filler and a proximal portion of the distal space filler;

inflating the proximal space filler, wherein inflating the proximal space filler causes the proximal sheath to be

10

rolled onto itself toward a proximal end of the proximal space filler and the central sheath to be rolled onto itself toward a distal end of the proximal space filler; and inflating the distal space filler, wherein inflating the distal space filler causes the central sheath to be rolled onto itself toward a proximal end of the distal space filler.

19. The method of claim 18 wherein the proximal sheath and the central sheath automatically uncover the proximal space filler and the distal space filler as the proximal space filler and the distal space filler are inflated, and wherein the central sheath remains in contact with the gastric space filler device after uncovering.

20. The method of claim 18 wherein a delivery system is attached to the gastric space filler device during delivery, and wherein the method further comprises detaching the delivery system from the gastric space filler device after inflating the distal space filler.

* * * * *

UNITED STATES PATENT AND TRADEMARK OFFICE
CERTIFICATE OF CORRECTION

PATENT NO. : 8,142,469 B2
APPLICATION NO. : 11/768152
DATED : March 27, 2012
INVENTOR(S) : Stephen Alexander Sosnowski et al.

Page 1 of 1

It is certified that error appears in the above-identified patent and that said Letters Patent is hereby corrected as shown below:

Title page 2, in column 2, under "Other Publications", line 49, delete "Ballon" and insert -- Balloon --, therefor.

In column 4, line 12, delete "larder" and insert -- larger --, therefor.

In column 8, line 17, in claim 8, before "sheath" delete "stitch".

In column 8, line 20, in claim 9, delete "prevents" and insert -- prevent --, therefor.

In column 8, line 23, in claim 9, delete "allows" and insert -- allow --, therefor.

In column 8, line 43, in claim 12, after "filler" insert -- device --.

In column 8, line 45, in claim 13, after "filler" insert -- device --.

In column 9, line 4, in claim 17, delete "allows" and insert -- allow --, therefor.

Signed and Sealed this
Tenth Day of July, 2012

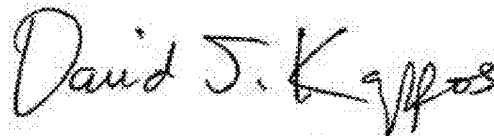

David J. Kappos
Director of the United States Patent and Trademark Office