



US008696751B2

(12) **United States Patent**  
**Ashley et al.**

(10) **Patent No.:** **US 8,696,751 B2**  
(45) **Date of Patent:** **\*Apr. 15, 2014**

(54) **ADJUSTABLE DISTRACTION CAGE WITH LINKED LOCKING MECHANISMS**

(75) Inventors: **John E. Ashley**, Danville, CA (US); **Philip J. Simpson**, Escondido, CA (US); **Walter Dean Gillespie**, Carlsbad, CA (US); **Damien J. Shulock**, San Francisco, CA (US); **Murali Kadaba**, Emerald Hills, CA (US); **David G. Matsuura**, Encinitas, CA (US); **George A. Mansfield, III**, San Diego, CA (US); **Thomas Grotz**, Novato, CA (US); **Rudy Pretti**, Auburn, CA (US)

(73) Assignee: **CoAlign Innovations, Inc.**, Redwood City, CA (US)

(\* ) Notice: Subject to any disclaimer, the term of this patent is extended or adjusted under 35 U.S.C. 154(b) by 351 days.  
This patent is subject to a terminal disclaimer.

(21) Appl. No.: **12/787,281**

(22) Filed: **May 25, 2010**

(65) **Prior Publication Data**  
US 2011/0130835 A1 Jun. 2, 2011

**Related U.S. Application Data**

(63) Continuation-in-part of application No. PCT/US2009/067446, filed on Dec. 10, 2009, and a continuation-in-part of application No. 12/380,840, filed on Mar. 4, 2009, now abandoned.

(60) Provisional application No. 61/201,518, filed on Dec. 10, 2008.

(51) **Int. Cl.**  
**A61F 2/44** (2006.01)

(52) **U.S. Cl.**  
USPC ..... **623/17.16**

(58) **Field of Classification Search**  
USPC ..... 623/17.11-17.16; 606/246, 247  
See application file for complete search history.

(56) **References Cited**

U.S. PATENT DOCUMENTS

3,875,595 A 4/1975 Froning  
4,932,975 A 6/1990 Main et al.

(Continued)

FOREIGN PATENT DOCUMENTS

EP 1415624 5/2004  
EP 1442715 8/2004

(Continued)

OTHER PUBLICATIONS

Related U.S. Appl. No. 11/535,432, filed Sep. 26, 2006, in the name of Thomas Grotz et al., titled "Selectively Expanding Spine Cage, Hydraulically Controllable in Three Dimensions for Enhanced Spinal Fusion."

(Continued)

*Primary Examiner* — Alvin Stewart

(74) *Attorney, Agent, or Firm* — Downs Rachlin Martin PLLC

(57) **ABSTRACT**

A spinal implant which is configured to be deployed between adjacent vertebral bodies. The implant has at least one extendable support element with a refracted configuration to facilitate deployment of the implant and an extended configuration so as to expand the implant and effectively distract the disc space, stabilize the motion segments and eliminate pathologic spine motion. The implant has a minimal dimension in its unexpanded state that is smaller than the dimensions of the neuroforamen through which it typically passes to be deployed within the intervertebral space. The implant is provided with a locking system having a plurality of linked locking elements that work in unison to lock the implant in an extended configuration. Bone engaging anchors also may be provided to ensure secure positioning.

**26 Claims, 43 Drawing Sheets**

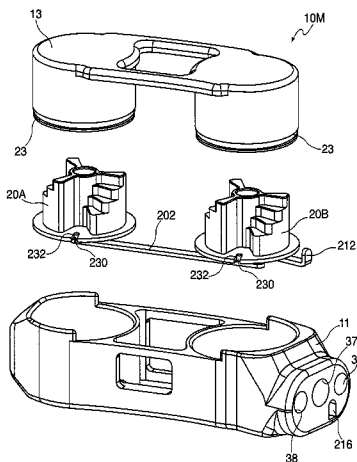

(56)

References Cited

U.S. PATENT DOCUMENTS

4,969,888 A 11/1990 Scholten et al.  
 5,236,460 A 8/1993 Barber  
 5,653,763 A 8/1997 Errico et al.  
 5,665,122 A 9/1997 Kambin  
 5,827,328 A 10/1998 Buttermann  
 5,865,848 A 2/1999 Baker  
 5,980,522 A 11/1999 Koros et al.  
 6,039,761 A 3/2000 Li et al.  
 6,102,950 A 8/2000 Vaccaro  
 6,127,597 A 10/2000 Beyar et al.  
 6,176,881 B1 1/2001 Schar et al.  
 6,193,756 B1 2/2001 Studer et al.  
 6,296,665 B1 10/2001 Strnad et al.  
 6,371,989 B1 4/2002 Chauvin et al.  
 6,375,682 B1 4/2002 Fleischmann et al.  
 6,375,683 B1 4/2002 Crozet et al.  
 6,395,032 B1 5/2002 Gauchet  
 6,454,806 B1 9/2002 Cohen et al.  
 6,692,495 B1 2/2004 Zacouto  
 6,719,796 B2 4/2004 Cohen et al.  
 6,723,126 B1\* 4/2004 Berry ..... 623/17.11  
 6,730,088 B2\* 5/2004 Yeh ..... 606/247  
 6,764,491 B2 7/2004 Frey et al.  
 6,875,235 B2 4/2005 Ferree  
 6,981,989 B1 1/2006 Fleischmann et al.  
 7,001,431 B2 2/2006 Bao et al.  
 7,018,415 B1 3/2006 McKay  
 7,018,416 B2 3/2006 Hanson et al.  
 7,060,073 B2 6/2006 Frey et al.  
 7,094,257 B2\* 8/2006 Mujwid et al. .... 623/17.15  
 7,166,110 B2 1/2007 Yundt  
 7,204,853 B2 4/2007 Gordon et al.  
 7,214,243 B2 5/2007 Taylor  
 7,217,293 B2 5/2007 Branch, Jr.  
 7,282,063 B2 10/2007 Cohen et al.  
 7,291,150 B2 11/2007 Graf  
 7,291,158 B2 11/2007 Crow et al.  
 7,316,686 B2 1/2008 Dorchak et al.  
 7,316,714 B2 1/2008 Gordon et al.  
 7,351,261 B2 4/2008 Casey  
 7,670,359 B2 3/2010 Yundt  
 7,722,674 B1 5/2010 Grotz  
 7,794,501 B2 9/2010 Edie et al.  
 7,819,921 B2 10/2010 Grotz  
 7,854,766 B2\* 12/2010 Moskowitz et al. .... 623/17.15  
 7,985,256 B2\* 7/2011 Grotz et al. .... 623/17.11  
 2002/0128716 A1 9/2002 Cohen et al.  
 2002/0138146 A1 9/2002 Jackson  
 2002/0151976 A1 10/2002 Foley et al.  
 2003/0114899 A1 6/2003 Woods et al.  
 2004/0088054 A1\* 5/2004 Berry ..... 623/17.11  
 2004/0133273 A1 7/2004 Cox  
 2005/0043800 A1 2/2005 Paul et al.  
 2005/0085910 A1\* 4/2005 Sweeney ..... 623/17.11  
 2005/0113842 A1 5/2005 Bertagnoli et al.  
 2005/0197702 A1 9/2005 Coppes et al.  
 2005/0216084 A1\* 9/2005 Fleischmann et al. .... 623/17.11  
 2005/0229433 A1 10/2005 Cachia  
 2005/0273169 A1 12/2005 Purcell  
 2005/0273170 A1 12/2005 Navarro et al.  
 2005/0273171 A1 12/2005 Gordon et al.  
 2006/0036259 A1 2/2006 Carl et al.  
 2006/0085073 A1 4/2006 Raiszadeh  
 2006/0106416 A1 5/2006 Raymond et al.  
 2006/0116767 A1 6/2006 Magerl et al.  
 2006/0149377 A1 7/2006 Navarro et al.  
 2006/0167547 A1 7/2006 Suddaby  
 2006/0200244 A1\* 9/2006 Assaker ..... 623/17.15  
 2006/0235426 A1 10/2006 Lim et al.  
 2006/0235535 A1 10/2006 Ferree et al.  
 2006/0264968 A1 11/2006 Frey et al.  
 2007/0050030 A1 3/2007 Kim  
 2007/0050033 A1 3/2007 Reo et al.  
 2007/0073395 A1 3/2007 Baumgartner et al.  
 2007/0093901 A1 4/2007 Grotz et al.

2007/0093903 A1 4/2007 Cheng  
 2007/0123987 A1 5/2007 Bernstein  
 2007/0179611 A1 8/2007 DiPoto et al.  
 2007/0233254 A1 10/2007 Grotz et al.  
 2007/0255409 A1\* 11/2007 Dickson et al. .... 623/17.11  
 2007/0255413 A1\* 11/2007 Edie et al. .... 623/17.16  
 2007/0255415 A1 11/2007 Edie et al.  
 2007/0288092 A1 12/2007 Bambakidis  
 2008/0058930 A1 3/2008 Edie et al.  
 2008/0065082 A1 3/2008 Chang et al.  
 2008/0077150 A1 3/2008 Nguyen  
 2008/0103601 A1\* 5/2008 Biro et al. .... 623/17.16  
 2008/0114467 A1\* 5/2008 Capote et al. .... 623/23.47  
 2008/0147194 A1 6/2008 Grotz et al.  
 2008/0161933 A1\* 7/2008 Grotz et al. .... 623/17.16  
 2008/0177387 A1\* 7/2008 Parimore et al. .... 623/17.16  
 2008/0281424 A1\* 11/2008 Parry et al. .... 623/17.16  
 2008/0300598 A1\* 12/2008 Barreiro et al. .... 606/63  
 2009/0043312 A1 2/2009 Koullisis et al.  
 2009/0204215 A1\* 8/2009 McClintock et al. .... 623/17.11  
 2009/0216331 A1 8/2009 Grotz et al.  
 2009/0222100 A1\* 9/2009 Cipoletti et al. .... 623/17.16  
 2009/0270987 A1 10/2009 Heinz et al.  
 2010/0057204 A1\* 3/2010 Kadaba et al. .... 623/17.12  
 2010/0145455 A1\* 6/2010 Simpson et al. .... 623/17.16  
 2010/0145456 A1\* 6/2010 Simpson et al. .... 623/17.16  
 2010/0249930 A1\* 9/2010 Myers ..... 623/13.14  
 2011/0130835 A1\* 6/2011 Ashley et al. .... 623/17.11  
 2011/0137416 A1\* 6/2011 Myers ..... 623/13.14  
 2011/0270398 A1\* 11/2011 Grotz et al. .... 623/17.12  
 2011/0288646 A1\* 11/2011 Moskowitz et al. .... 623/17.16  
 2012/0059469 A1\* 3/2012 Myers et al. .... 623/13.14  
 2012/0130387 A1\* 5/2012 Simpson et al. .... 606/104  
 2012/0245695 A1\* 9/2012 Simpson et al. .... 623/17.16  
 2012/0283830 A1\* 11/2012 Myers ..... 623/13.12  
 2013/0096677 A1\* 4/2013 Myers et al. .... 623/13.13  
 2013/0158669 A1\* 6/2013 Sungarian et al. .... 623/17.16  
 2013/0197642 A1\* 8/2013 Ernst ..... 623/17.16  
 2013/0197647 A1\* 8/2013 Wolters et al. .... 623/17.16  
 2013/0197648 A1\* 8/2013 Boehm et al. .... 623/17.16  
 2013/0204368 A1\* 8/2013 Prevost ..... 623/17.11  
 2013/0204374 A1\* 8/2013 Milella, Jr. .... 623/17.16

FOREIGN PATENT DOCUMENTS

WO 2004016205 A2 2/2004  
 WO 2004016250 2/2004  
 WO 2008011371 1/2008  
 WO 2008039811 4/2008  
 WO 2008121251 10/2008  
 WO 2009105182 8/2009  
 WO 2010068725 6/2010  
 WO 2011150077 12/2011

OTHER PUBLICATIONS

Related U.S. Appl. No. 12/548,260, filed Aug. 26, 2009, in the name of Murali Kadaba, titled "Hydraulically Actuated Expanding Spine Cage With Extendable Locking Anchor."  
 Related U.S. Appl. No. 12/380,840, filed Mar. 4, 2009, in the name of Philip J. Simpson et al., titled "Lockable Spinal Implant."  
 Related International Application No. PCT/US2009/067446 filed Dec. 10, 2009, in the name of Innvotec Surgical, Inc., titled "Lockable Expanding Spine Cage."  
 International Search Report and Written Opinion dated Aug. 13, 2010, in related International Application No. PCT/US2009/067446 filed Dec. 10, 2009.  
 Related International Application No. PCT/US2009/00974 filed Feb. 17, 2009, in the name of Innvotec Surgical, Inc., titled "Spinal Implant with Expandable Fixation."  
 International Search Report and Written Opinion dated May 6, 2009, in related International Application No. PCT/US2009/000974 filed Feb. 17, 2009.  
 Related International Application No. PCT/US2008/003776 filed Mar. 21, 2008, in the name of Innvotec Surgical, Inc., titled "Selectively Expanding Spine Cage, Hydraulically Controllable in Three Dimensions for Vertebral Body Replacement."

(56)

**References Cited**

## OTHER PUBLICATIONS

International Search Report and Written Opinion dated Jun. 30, 2009, in related International Application No. PCT/US2008/003776 filed Mar. 21, 2008.

Related U.S. Appl. No. 11/692,800, filed Mar. 28, 2007, in the name of R. Thomas Grotz et al., titled "Selectively Expanding Spine Cage, Hydraulically Controllable in Three Dimensions for Vertebral Body Replacement."

Office Action dated Sep. 16, 2010 in related U.S. Appl. No. 11/692,800, filed Mar. 28, 2007, in the name of R. Thomas Grotz et al., titled "Selectively Expanding Spine Cage, Hydraulically Controllable in Three Dimensions for Vertebral Body Replacement."

Related U.S. Appl. No. 12/072,044, filed Feb. 22, 2008, in the name of R. Thomas Grotz et al., titled "Spinal Implant with Expandable Fixation."

Related U.S. Appl. No. 11/981,452, filed Oct. 31, 2007, in the name of R. Thomas Grotz et al., titled "Selectively Expanding Spine Cage, Hydraulically Controllable in Three Dimensions for Vertebral Body Replacement."

Related U.S. Appl. No. 11/981,150, filed Oct. 31, 2007, in the name of R. Thomas Grotz et al., titled "Selectively Expanding Spine Cage, Hydraulically Controllable in Three Dimensions for Vertebral Body Replacement."

Related U.S. Appl. No. 12/384,622, filed Apr. 7, 2009, in the name of Philip J. Simpson et al., titled "Lockable Spinal Implant."

Preliminary Amendment dated Dec. 4, 2007 in related U.S. Appl. No. 11/535,432, titled "Selectively Expanding Spine Cage, Hydraulically Controllable in Three Dimensions for Enhanced Spinal Fusion."

Second Preliminary Amendment dated Mar. 18, 2008 in related U.S. Appl. No. 11/535,432, titled "Selectively Expanding Spine Cage, Hydraulically Controllable in Three Dimensions for Enhanced Spinal Fusion."

Third Preliminary Amendment dated Aug. 7, 2008 in related U.S. Appl. No. 11/535,432, titled "Selectively Expanding Spine Cage, Hydraulically Controllable in Three Dimensions for Enhanced Spinal Fusion."

Restriction Requirement dated Mar. 17, 2010 in related U.S. Appl. No. 11/535,432, titled "Selectively Expanding Spine Cage, Hydraulically Controllable in Three Dimensions for Enhanced Spinal Fusion."

Response to Restriction Requirement dated Mar. 31, 2010 in related U.S. Appl. No. 11/535,432, titled "Selectively Expanding Spine Cage, Hydraulically Controllable in Three Dimensions for Enhanced Spinal Fusion."

Office Action dated Jul. 9, 2010 in related U.S. Appl. No. 11/535,432, titled "Selectively Expanding Spine Cage, Hydraulically Controllable in Three Dimensions for Enhanced Spinal Fusion."

Response to Office Action dated Oct. 4, 2010 in related U.S. Appl. No. 11/535,432, titled "Selectively Expanding Spine Cage, Hydraulically Controllable in Three Dimensions for Enhanced Spinal Fusion."

Preliminary Amendment dated Oct. 31, 2007 in related U.S. Appl. No. 11/981,452, filed Oct. 31, 2007, titled "Selectively Expanding Spine Cage, Hydraulically Controllable in Three Dimensions for Vertebral Body Replacement."

Preliminary Amendment dated Oct. 31, 2007 in related U.S. Appl. No. 11/981,150, filed Oct. 31, 2007, titled "Selectively Expanding Spine Cage, Hydraulically Controllable in Three Dimensions for Vertebral Body Replacement."

International Search Report and Written Opinion dated Apr. 10, 2008, in related International Application No. PCT/US2007/079474.

Preliminary Amendment dated Dec. 11, 2009, in related U.S. Appl. No. 12/548,260, filed Aug. 26, 2009, in the name of Murali Kadaba, titled "Hydraulically Actuated Expanding Spine Cage With Extendable Locking Anchor."

Response to Office Action dated Dec. 16, 2010, in related U.S. Appl. No. 11/692,800 entitled "Selectively Expanding Spine Cage, Hydraulically Controllable in Three Dimensions for Vertebral Body Replacement."

Terminal Disclaimer dated Dec. 16, 2010, in related U.S. Appl. No. 11/692,800 entitled "Selectively Expanding Spine Cage, Hydraulically Controllable in Three Dimensions for Vertebral Body Replacement."

Restriction Requirement dated Dec. 27, 2010, in related U.S. Appl. No. 12/072,044 entitled "Spinal Implant With Expandable Fixation." Amendment and Response to Restriction Requirement dated Jan. 27, 2011, in related U.S. Appl. No. 12/072,044 entitled "Spinal Implant With Expandable Fixation."

International Search Report and Written Opinion dated Nov. 11, 2010, in International Application No. PCT/US2010/031247 entitled "Insertion Handle for Implant."

Final Office Action dated Feb. 1, 2011, in related U.S. Appl. No. 11/535,432 entitled "Selectively Expanding Spine Cage, Hydraulically Controllable in Three Dimensions for Enhanced Spinal Fusion."

Restriction Requirement dated Jan. 10, 2012, in related U.S. Appl. No. 12/548,260 entitled "Hydraulically Actuated Expanding Spine Cage with Extendable Locking Anchor."

Examination Report dated Oct. 18, 2011 in related EU Application No. 08727082.3 in the name of CoAlign Innovations, Inc.

Final Office Action dated Mar. 2, 2011, in related U.S. Appl. No. 11/692,800 entitled "Selectively Expanding Spine Cage, Hydraulically Controllable in Three Dimensions for Vertebral Body Replacement."

Response to Final Office Action dated Mar. 23, 2011, in related U.S. Appl. No. 11/535,432 entitled "Selectively Expanding Spine Cage, Hydraulically Controllable in Three Dimensions for Enhanced Spinal Fusion."

International Search Report and Written Opinion dated Sep. 22, 2011 in related International Application No. PCT/US2011/037929.

Final Office Action dated Nov. 18, 2011 in related U.S. Appl. No. 12/072,044, filed Feb. 22, 2008.

Response to Office Action filed Nov. 18, 2011 in related U.S. Appl. No. 12/384,622, filed Apr. 7, 2009.

Office Action dated Apr. 5, 2011, in related U.S. Appl. No. 11/981,150 entitled "Selectively Expanding Spine Cage, Hydraulically Controllable in Three Dimensions for Enhanced Spinal Fusion."

Office Action dated Mar. 31, 2011, in related U.S. Appl. No. 11/981,452 entitled "Selectively Expanding Spine Cage, Hydraulically Controllable in Three Dimensions for Vertebral Body Replacement."

Restriction Requirement dated Apr. 4, 2011, in related U.S. Appl. No. 12/384,622 entitled "Lockable Spinal Implant."

Notice of Allowance dated Apr. 13, 2011, in related U.S. Appl. No. 11/535,432, entitled "Selectively Expanding Spine Cage, Hydraulically Controllable in Three Dimensions for Enhanced Spinal Fusion."

Restriction Requirement dated May 2, 2011, in related U.S. Appl. No. 12/380,840 entitled "Lockable Spinal Implant."

Response to Final Office Action dated May 2, 2011, in related U.S. Appl. No. 11/692,800 entitled "Selectively Expanding Spine Cage, Hydraulically Controllable in Three Dimensions for Vertebral Body Replacement."

Related U.S. Appl. No. 13/183,080, filed Jul. 14, 2011, in the name of Thomas Grotz et al., entitled "Selectively Expanding Spine Cage, Hydraulically Controllable in Three Dimensions for Enhanced Spinal Fusion."

Notice of Allowance dated Aug. 3, 2011, in related U.S. Appl. No. 11/692,800, entitled "Selectively Expanding Spine Cage, Hydraulically Controllable in Three Dimensions for Vertebral Body Replacement."

Response to Office Action dated Aug. 9, 2011, in related U.S. Appl. No. 12/072,044, entitled "Spinal Implant With Expandable Fixation."

Office Action dated Aug. 31, 2011, in related U.S. Appl. No. 12/384,622, entitled "Lockable Spinal Implant."

Office Action dated May 9, 2011, in related U.S. Appl. No. 12/072,044 entitled "Spinal Implant With Expandable Fixation."

Response to Restriction Requirement dated Jun. 6, 2011, in related U.S. Appl. No. 12/384,622 entitled "Lockable Spinal Implant."

(56)

**References Cited**

## OTHER PUBLICATIONS

Related International Application No. PCT/US2011/037929 filed May 25, 2011, entitled "Adjustable Distraction Cage With Linked Locking Mechanisms."

Office Action dated Apr. 26, 2011, in related CN Application No. 200880016846.7, entitled "Selectively Expanding Spine Cage, Hydraulically Controllable in Three Dimensions for Vertebral Body Replacement."

Response to Office Action dated Jul. 5, 2011, in related U.S. Appl. No. 11/981,150, entitled "Selectively Expanding Spine Cage, Hydraulically Controllable in Three Dimensions for Enhanced Spinal Fusion."

Advisory Action dated May 19, 2011, in related U.S. Appl. No. 11/692,800, entitled "Selectively Expanding Spine Cage, Hydraulically Controllable in Three Dimensions for Vertebral Body Replacement."

Amendment After Final Office Action dated Jul. 5, 2011, in related U.S. Appl. No. 11/692,800, entitled "Selectively Expanding Spine Cage, Hydraulically Controllable in Three Dimensions for Vertebral Body Replacement."

Response to Final Office Action/RCE dated Mar. 19, 2012, in related U.S. Appl. No. 12/072,044, filed Feb. 22, 2008.

Response to Office Action dated Jul. 30, 2012, in related U.S. Appl. No. 12/072,044, filed Feb. 22, 2008.

Examination Report dated Jul. 17, 2012, in European Patent Application No. 09712948.0.

Notice of Allowance dated Feb. 23, 2012, in related U.S. Appl. No. 12/384,622, filed Apr. 7, 2009.

Response to Restriction Requirement dated Mar. 12, 2012, in related U.S. Appl. No. 12/548,260, filed Aug. 26, 2009.

Response to Office Action dated Feb. 17, 2012, in related U.S. Appl. No. 12/072,044, filed Feb. 22, 2008.

Advisory Action dated Mar. 12, 2012, in related U.S. Appl. No. 12/072,044, filed Feb. 22, 2008.

Response to Office Action dated Mar. 19, 2012, in related U.S. Appl. No. 12/072,044, filed Feb. 22, 2008.

Office Action dated Mar. 29, 2012, in related U.S. Appl. No. 12/072,044, filed Feb. 22, 2008.

Response to Final Office Action dated Jan. 21, 2013, in connection with related U.S. Appl. No. 12/072,044, filed Feb. 22, 2008.

Advisory Action dated Feb. 14, 2013, in connection with related U.S. Appl. No. 12/072,044, filed Feb. 22, 2008.

Second Response to Final Office Action dated Mar. 18, 2013, in connection with related U.S. Appl. No. 12/072,044, filed Feb. 22, 2008.

Advisory Action dated Apr. 17, 2013, in connection with related U.S. Appl. No. 12/072,044, filed Feb. 22, 2008.

Third Response After Final Action dated Apr. 19, 2013, in connection with related U.S. Appl. No. 12/072,044, filed Feb. 22, 2008.

Office Action dated Feb. 11, 2013, in connection with related European Patent Application No. 08727082.3 filed Mar. 21, 2008.

First Office Action dated Mar. 6, 2013, in connection with related Chinese Patent Application No. 200980106122.6 filed Feb. 17, 2009.

Office Action dated May 2, 2013, in connection with related Japanese Patent Application No. 2010-547621 filed Feb. 17, 2009.

Translated Second Office Action dated Apr. 26, 2012 in related China Application No. 200880016846.7.

Office Action dated Jun. 20, 2012, in related U.S. Appl. No. 13/183,080, filed Jul. 14, 2011.

Office Action dated Jun. 20, 2012, in related U.S. Appl. No. 13/311,487, filed Dec. 5, 2011.

Final Office Action dated Jun. 19, 2012, in related U.S. Appl. No. 11/981,150, filed Oct. 31, 2007.

Office Action dated Jun. 1, 2012, in related U.S. Appl. No. 12/548,260, filed Aug. 26, 2009.

Response to Final Office Action dated Oct. 18, 2012, in connection with related U.S. Appl. No. 11/981,150, filed Oct. 31, 2007.

Notice of Allowance dated Nov. 9, 2012, in connection with related U.S. Appl. No. 11/981,150, filed Oct. 31, 2007.

Response to Office Action dated Oct. 22, 2012, in connection with related U.S. Appl. No. 13/311,487, filed Dec. 5, 2011.

Response to Office Action dated Oct. 22, 2012, in connection with related U.S. Appl. No. 13/183,080, filed Jul. 14, 2011.

Supplemental Response to Final Office Action dated Jan. 4, 2013, in connection with related U.S. Appl. No. 12/548,260, filed Aug. 26, 2009.

Final Office Action dated Nov. 19, 2012, in connection with related U.S. Appl. No. 12/072,044, filed Feb. 22, 2008.

Response to Office Action dated Oct. 15, 2012, in connection with related U.S. Appl. No. 12/548,260, filed Aug. 26, 2009.

Final Office Action dated Oct. 30, 2012, in connection with related U.S. Appl. No. 12/548,260, filed Aug. 26, 2009.

Response to Final Office Action dated Dec. 31, 2012, in connection with related U.S. Appl. No. 12/548,260, filed Aug. 26, 2009.

\* cited by examiner

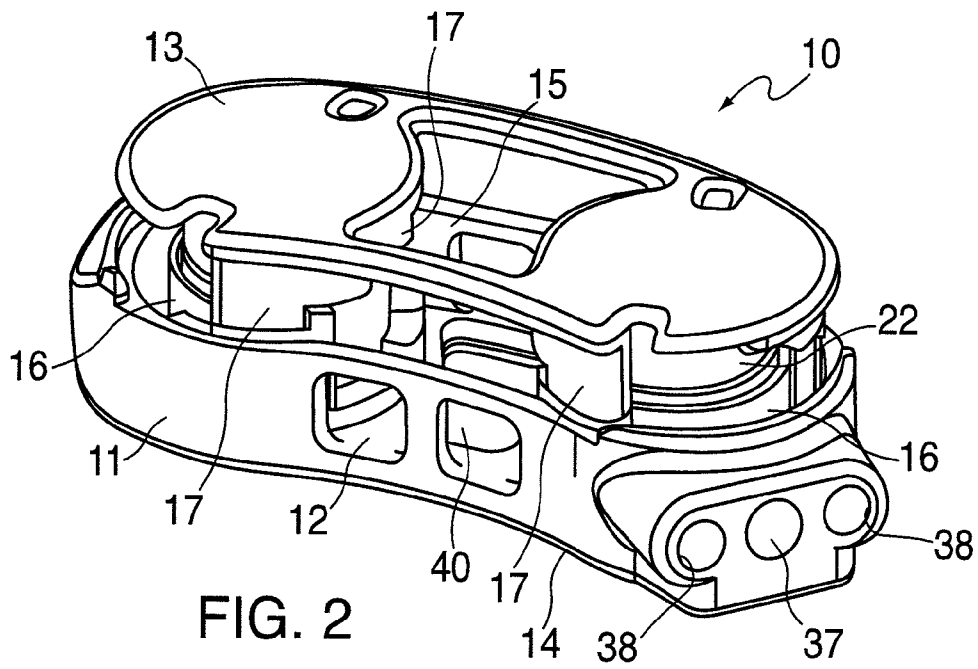
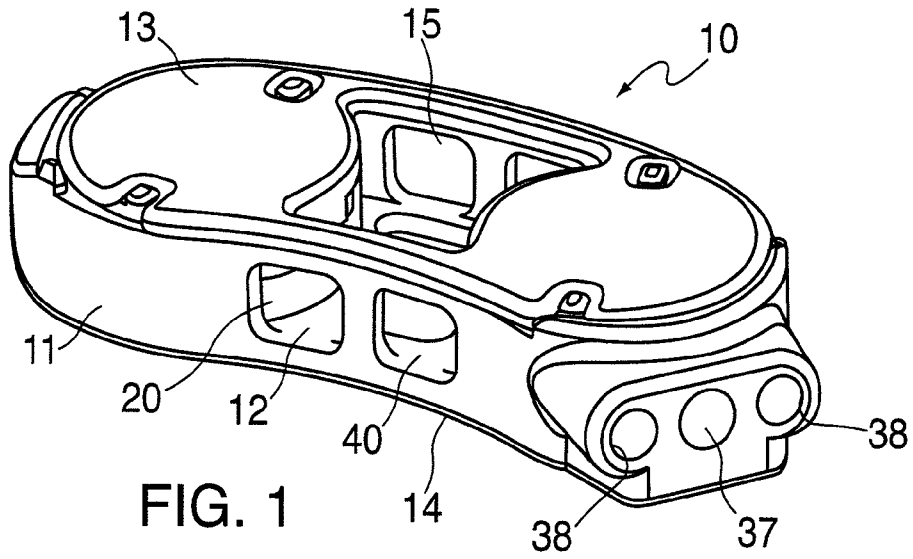

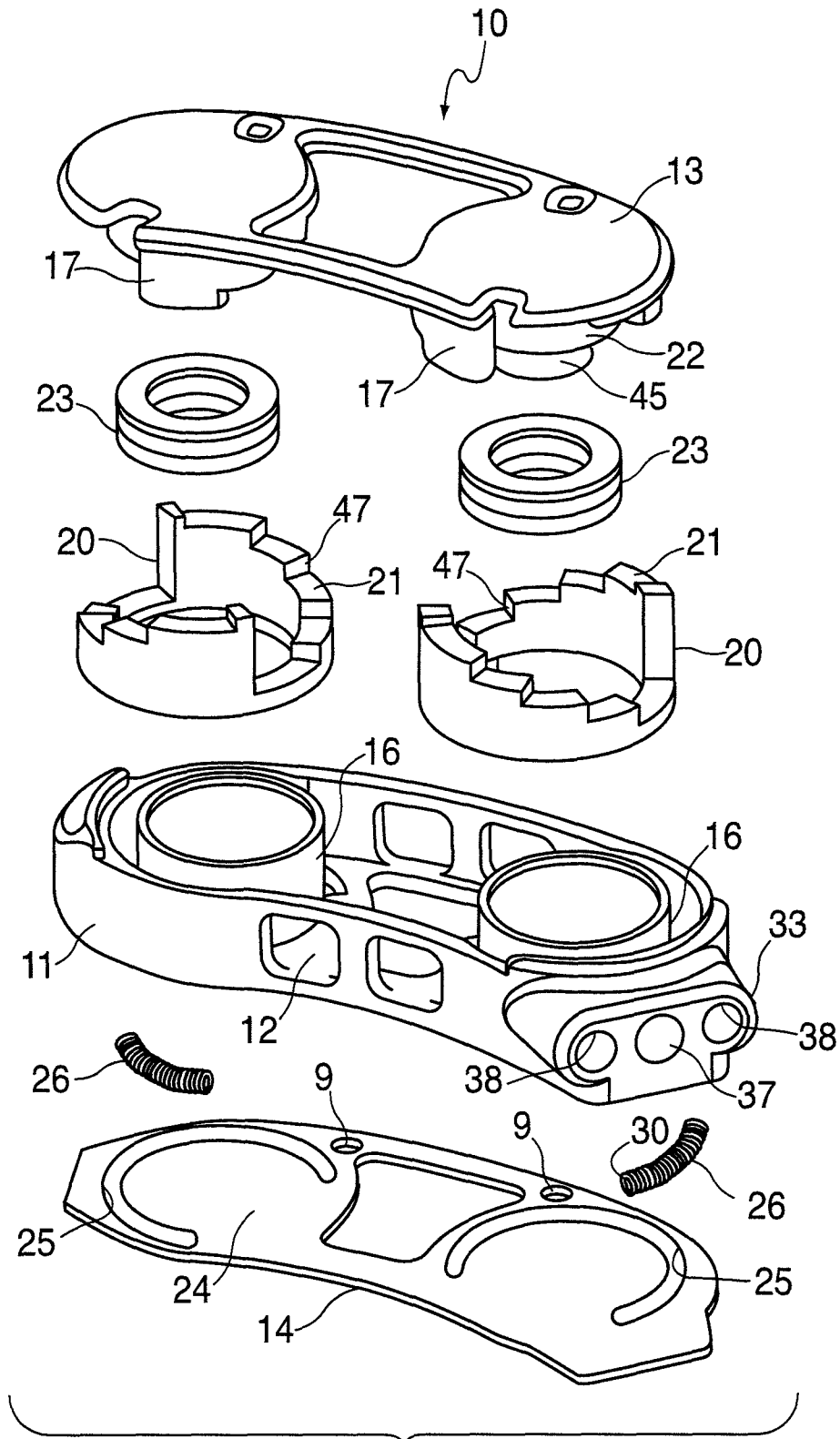

FIG. 3

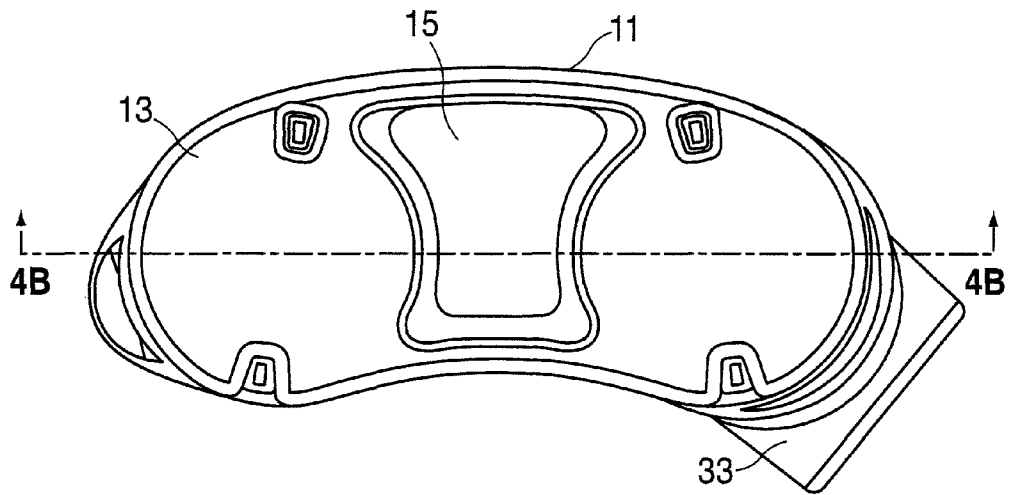

FIG. 4A

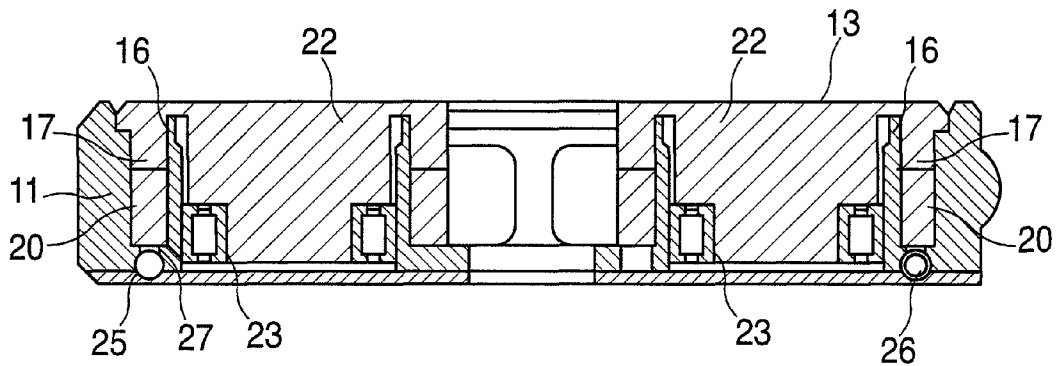

FIG. 4B

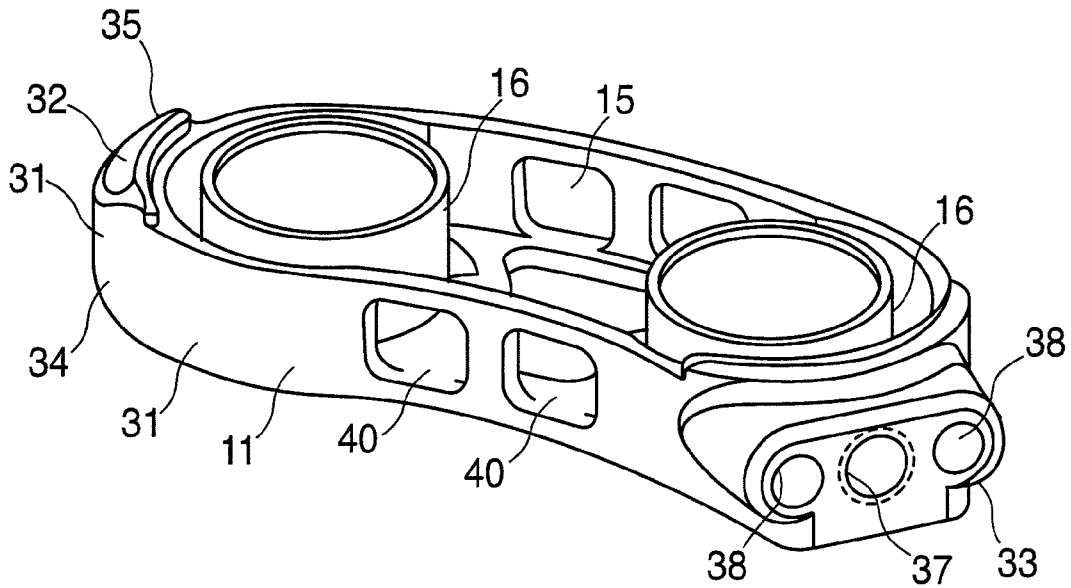

FIG. 5A

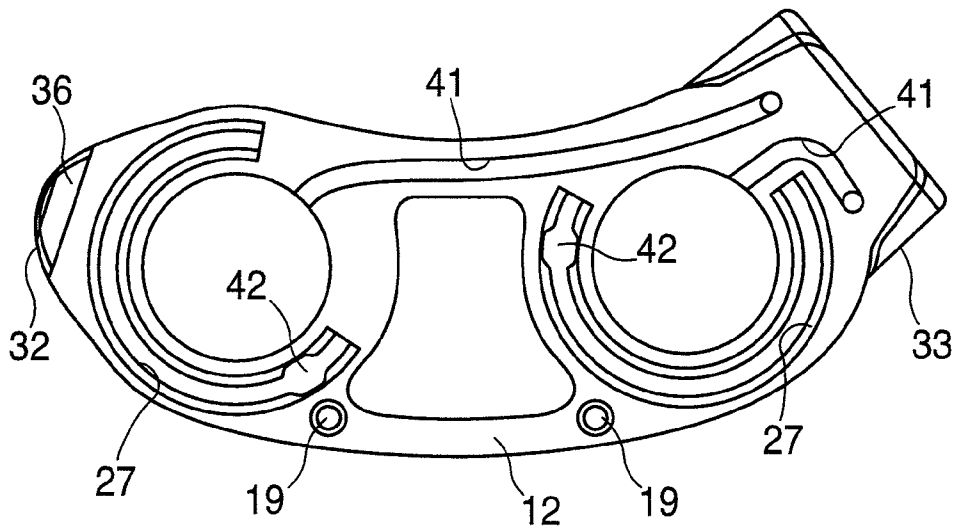
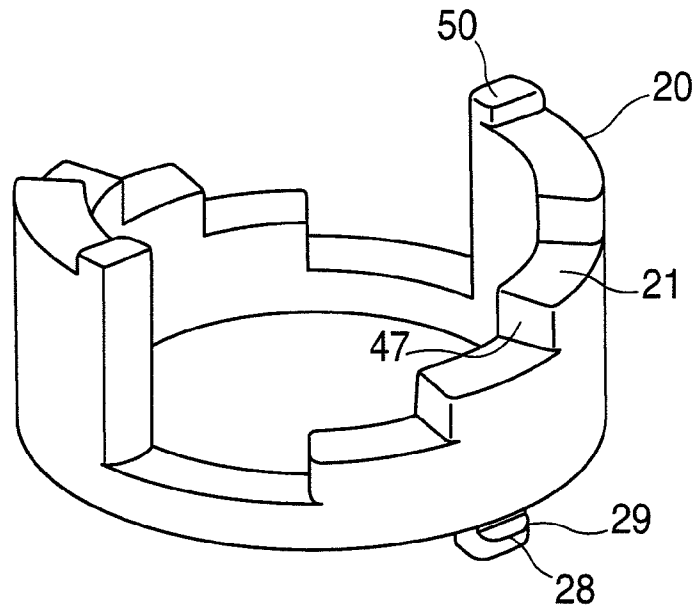
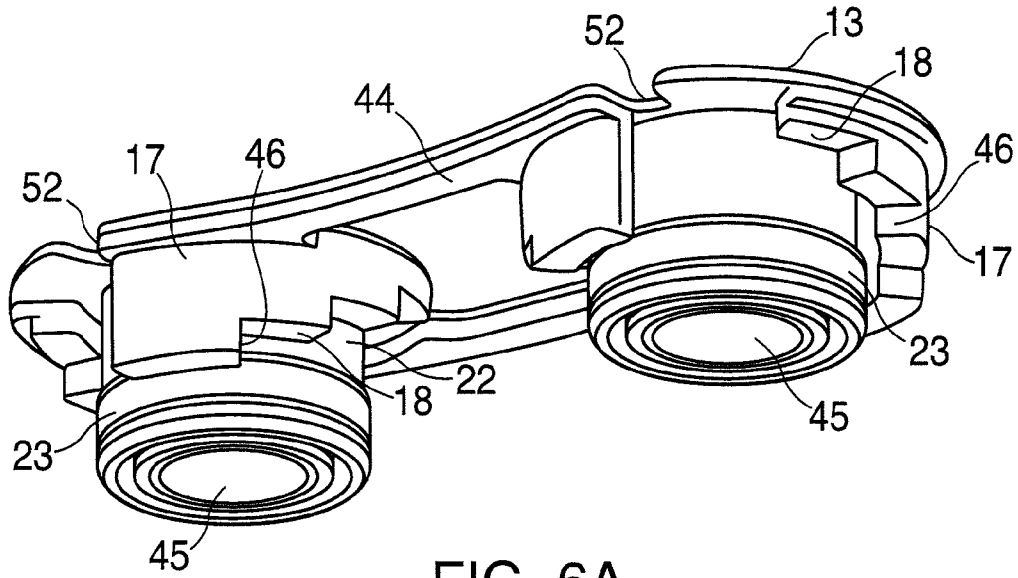

FIG. 5B





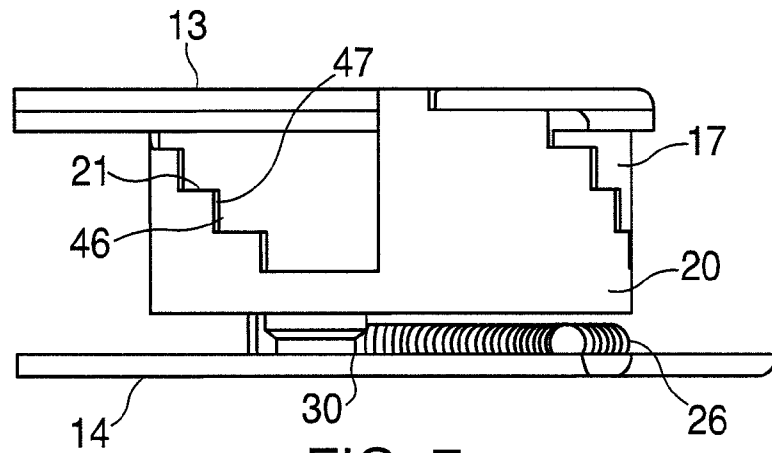

FIG. 7

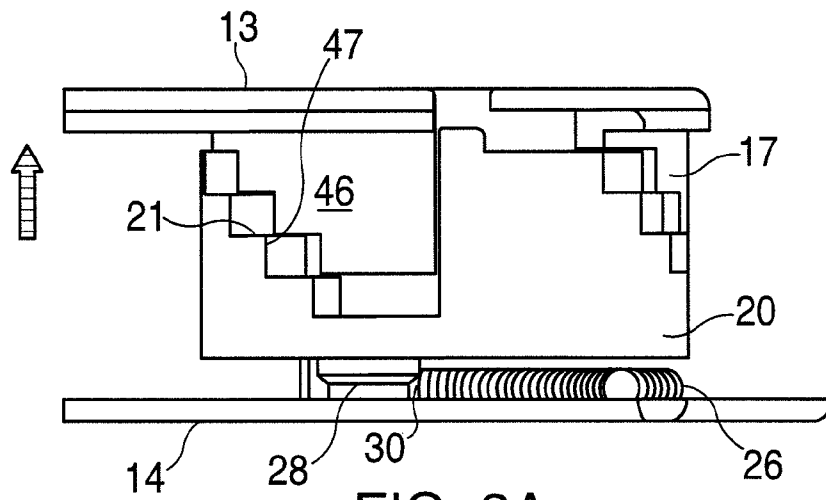

FIG. 8A

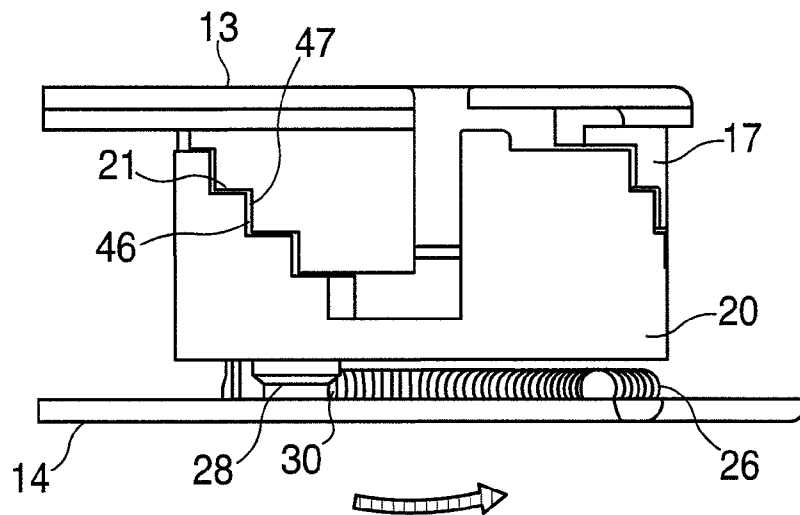

FIG. 8B

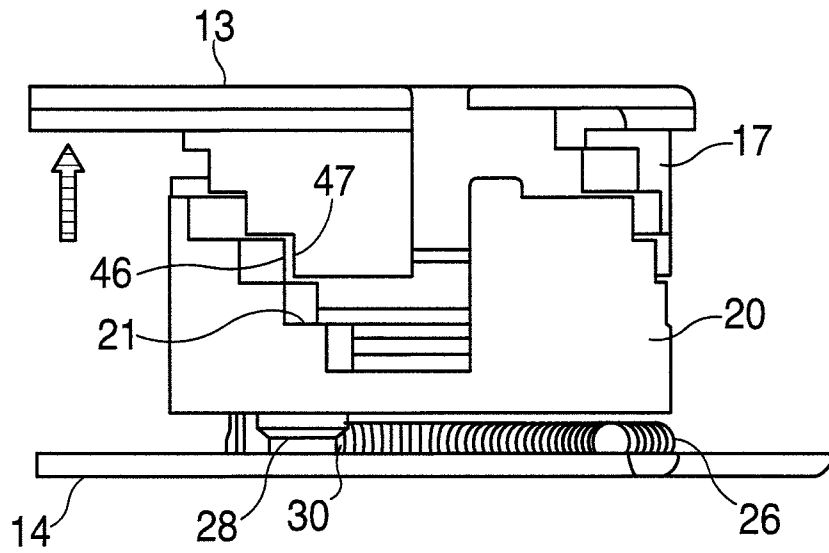

FIG. 9A

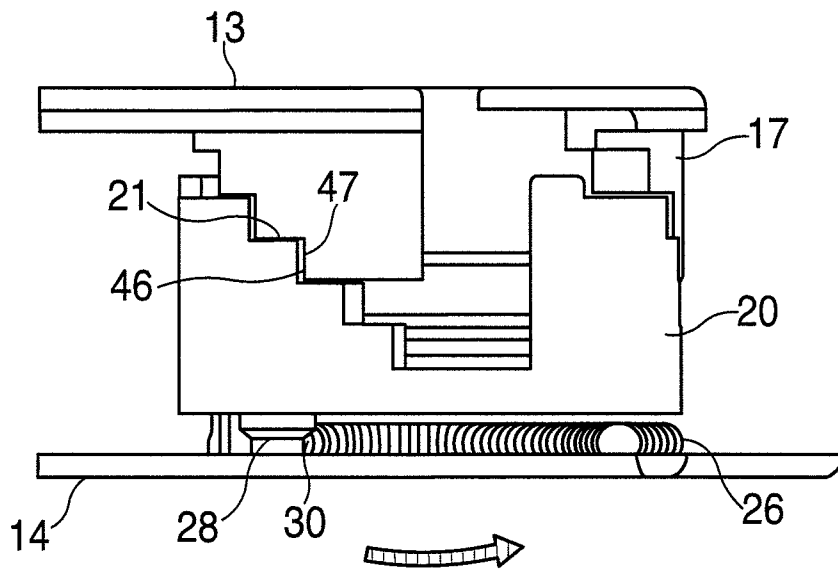

FIG. 9B

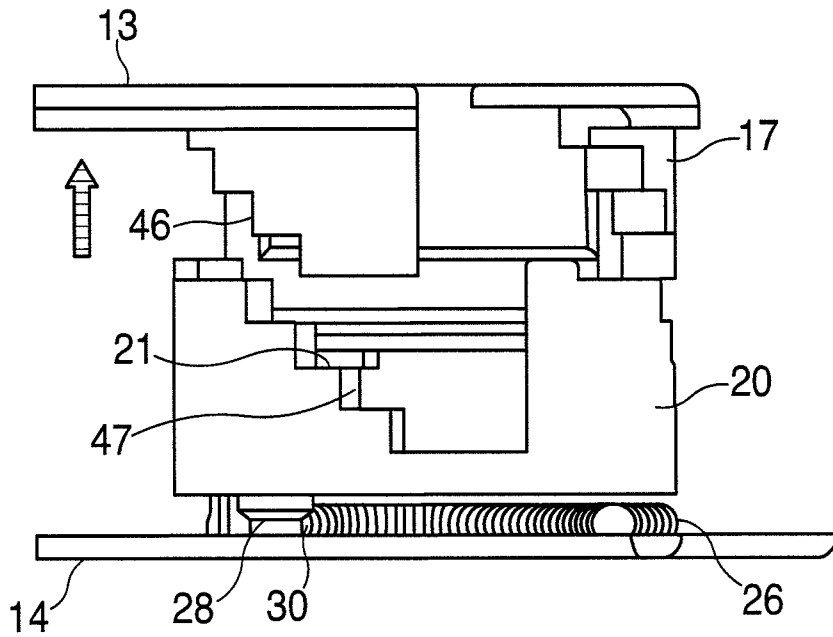

FIG. 10A

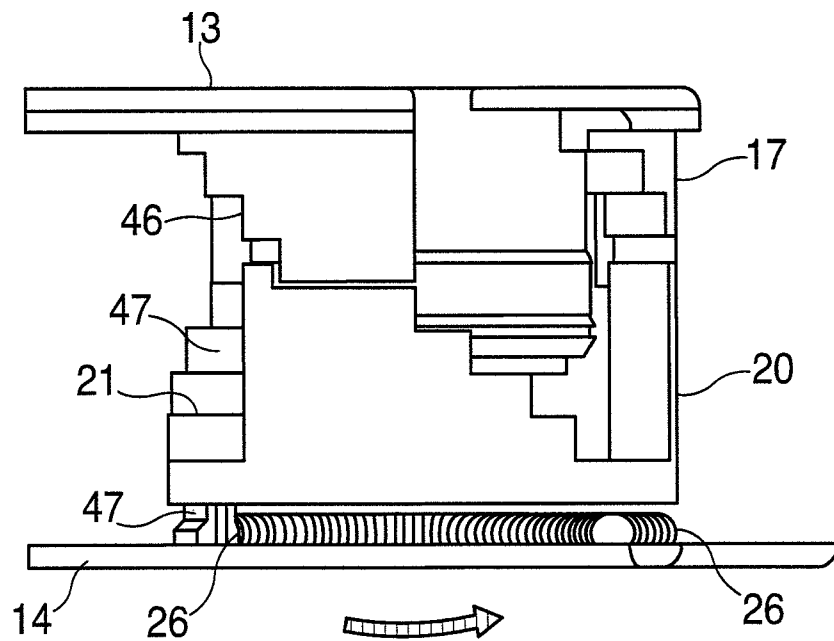
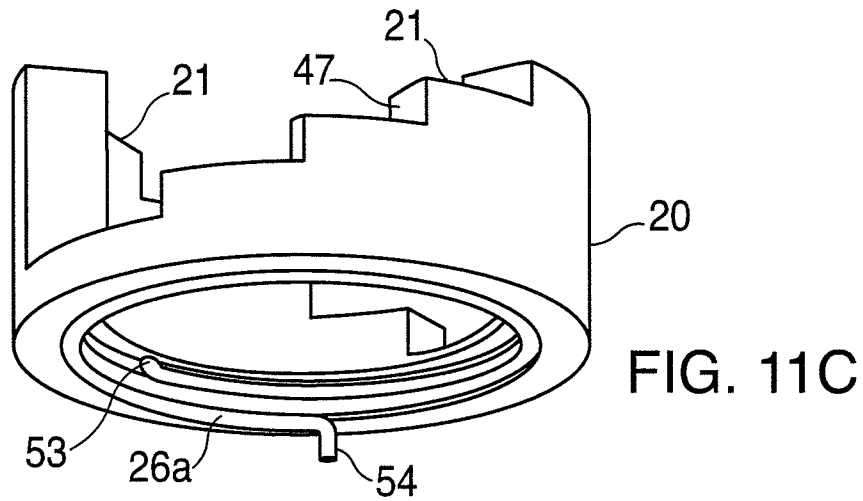
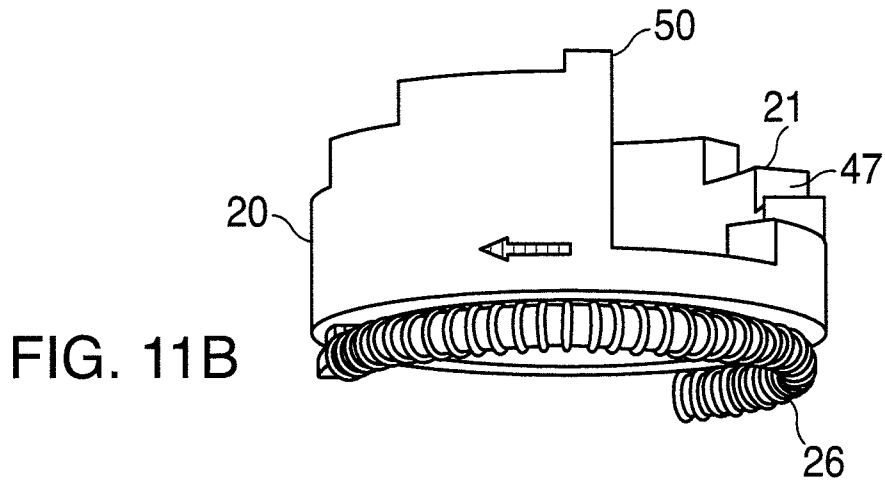
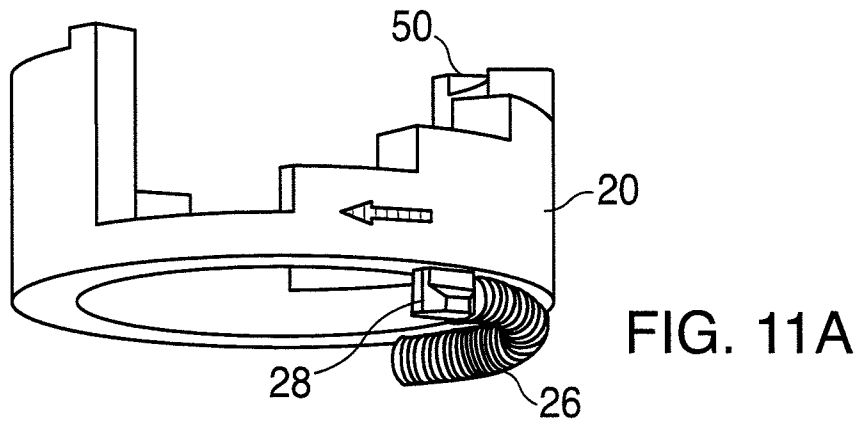

FIG. 10B



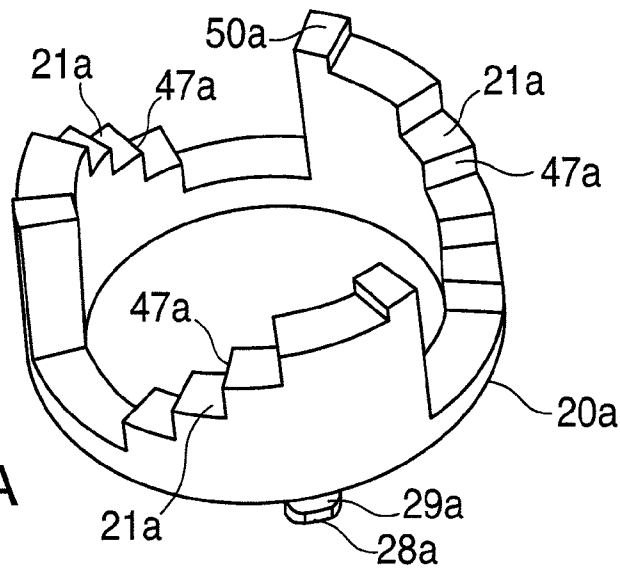

FIG. 12A

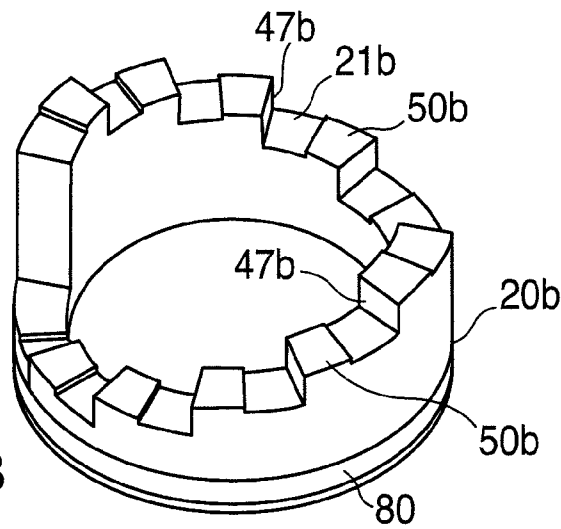

FIG. 12B

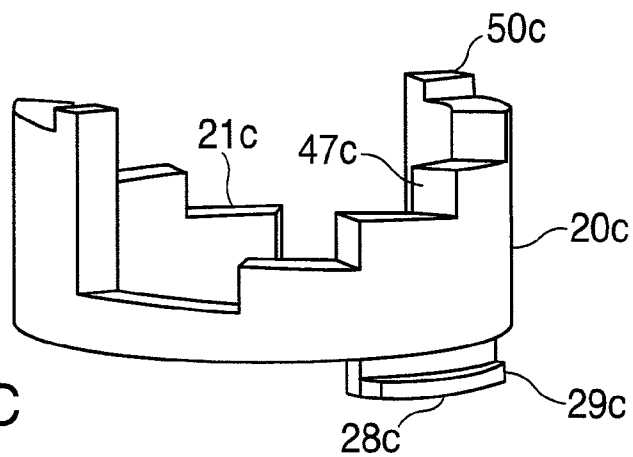

FIG. 12C

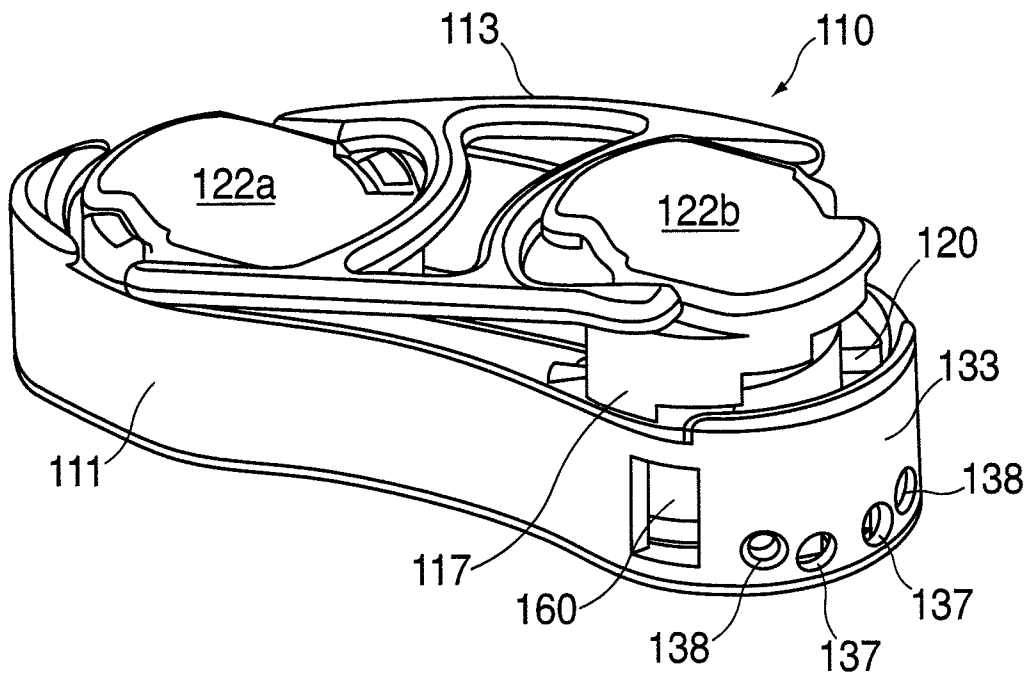

FIG. 13A

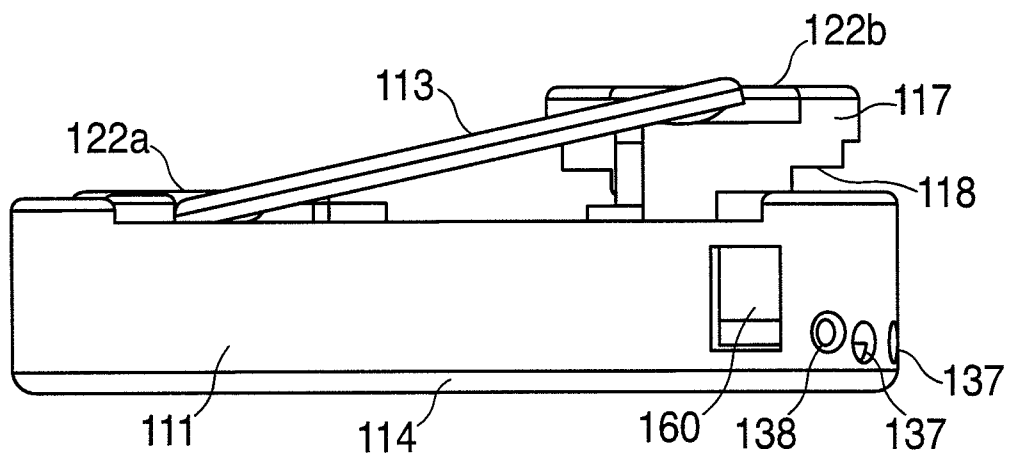

FIG. 13B

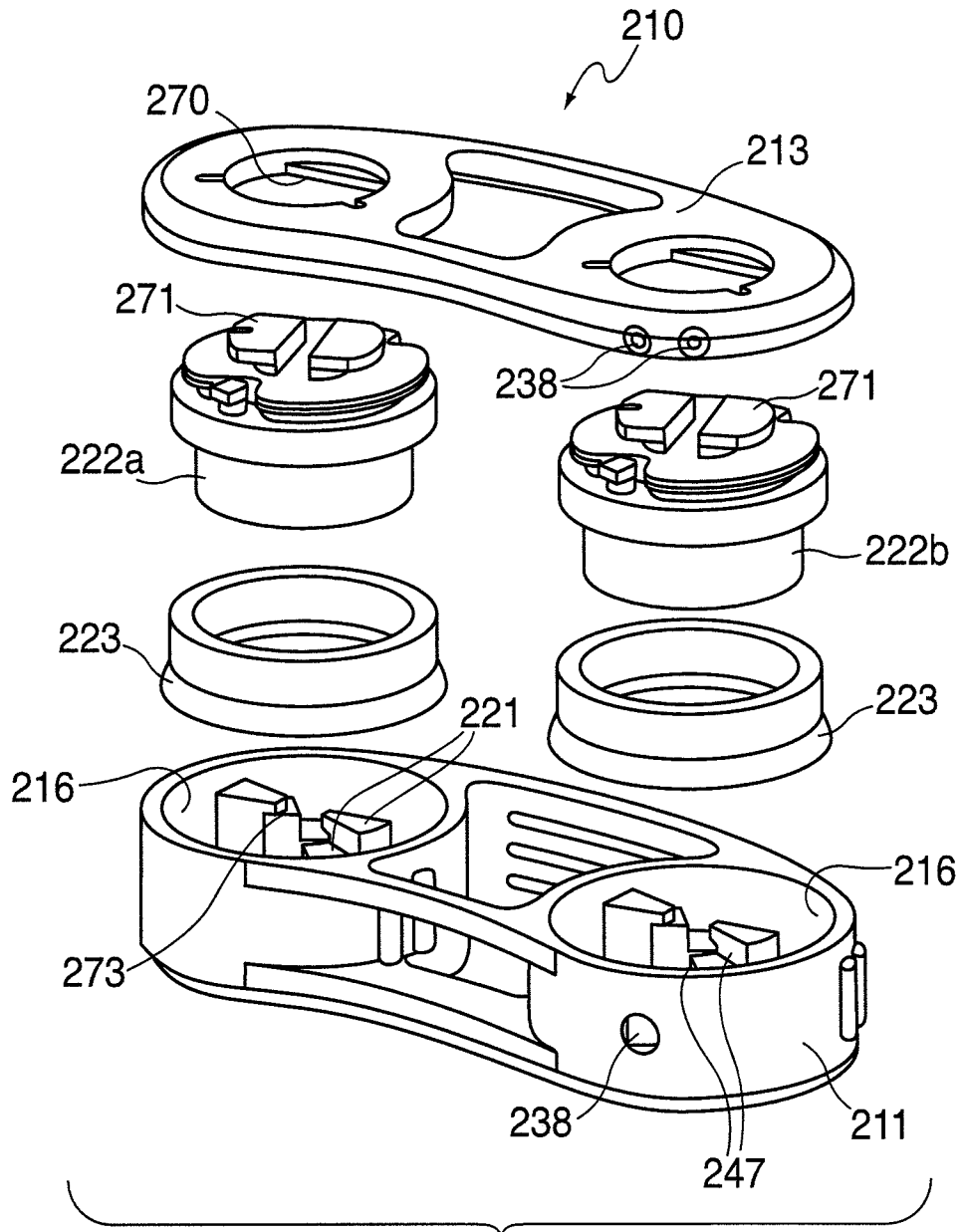

FIG. 14A



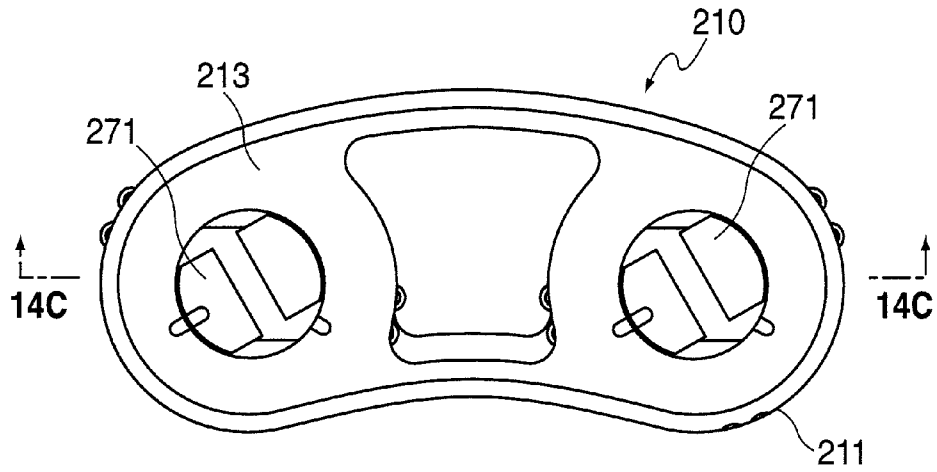

FIG. 14B

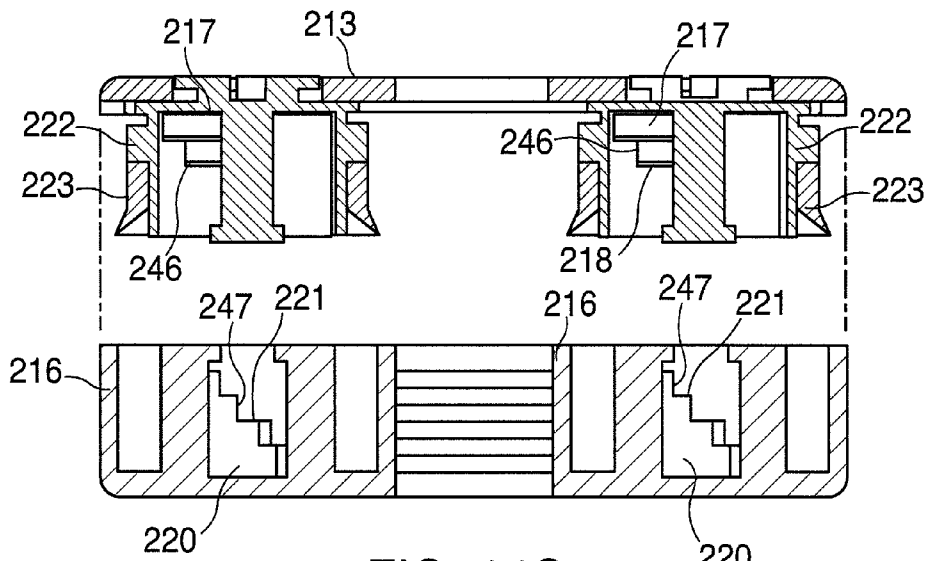

FIG. 14C

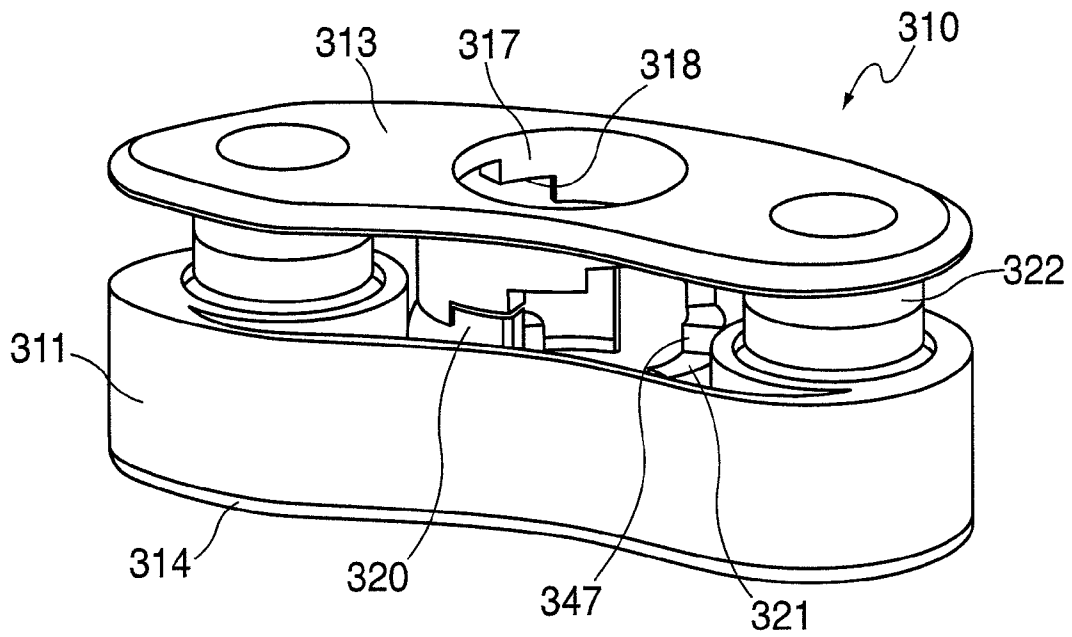

FIG. 15

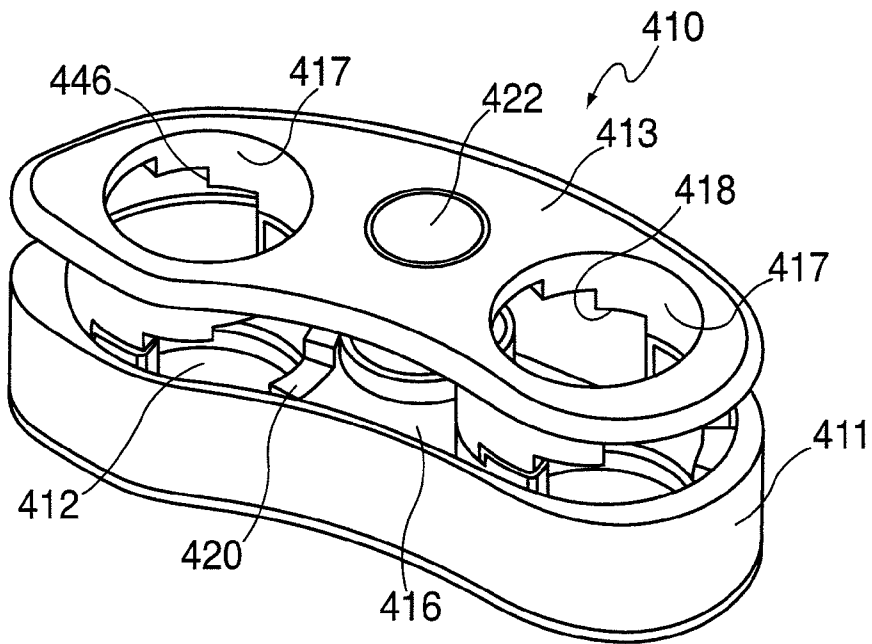

FIG. 16

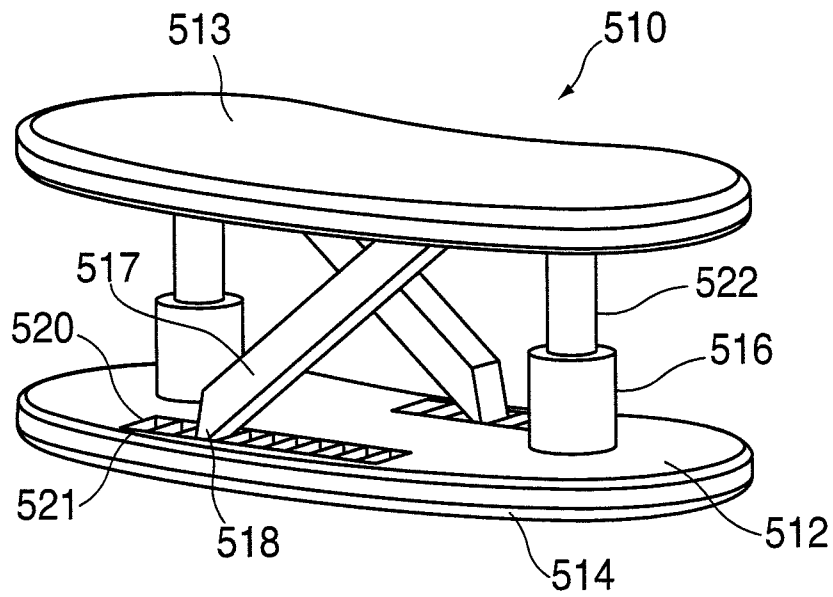

FIG. 17

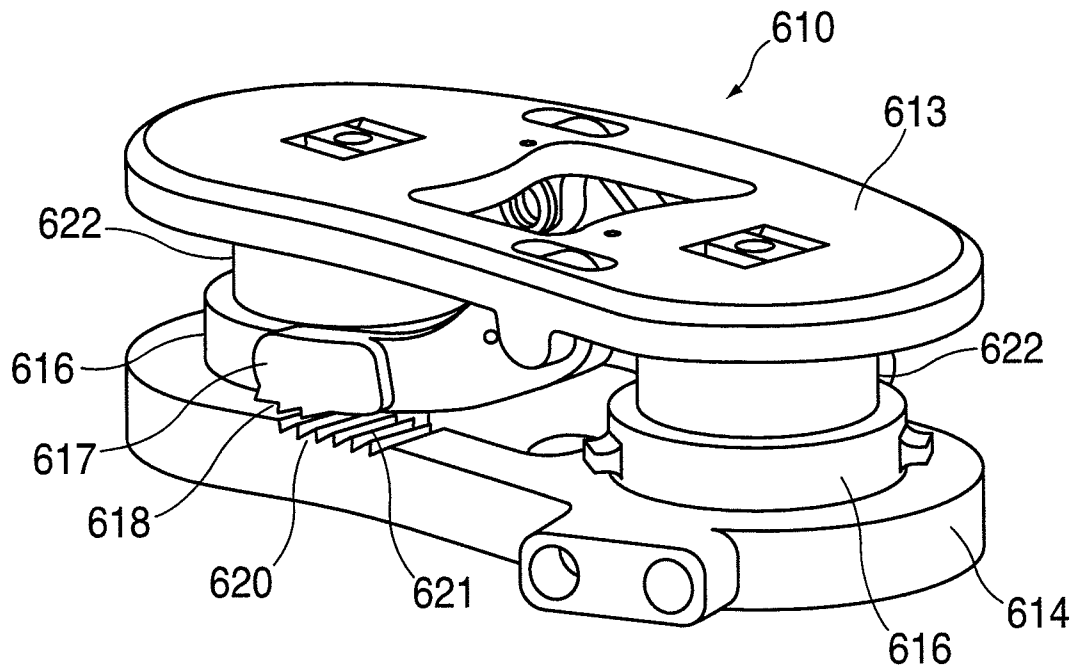

FIG. 18

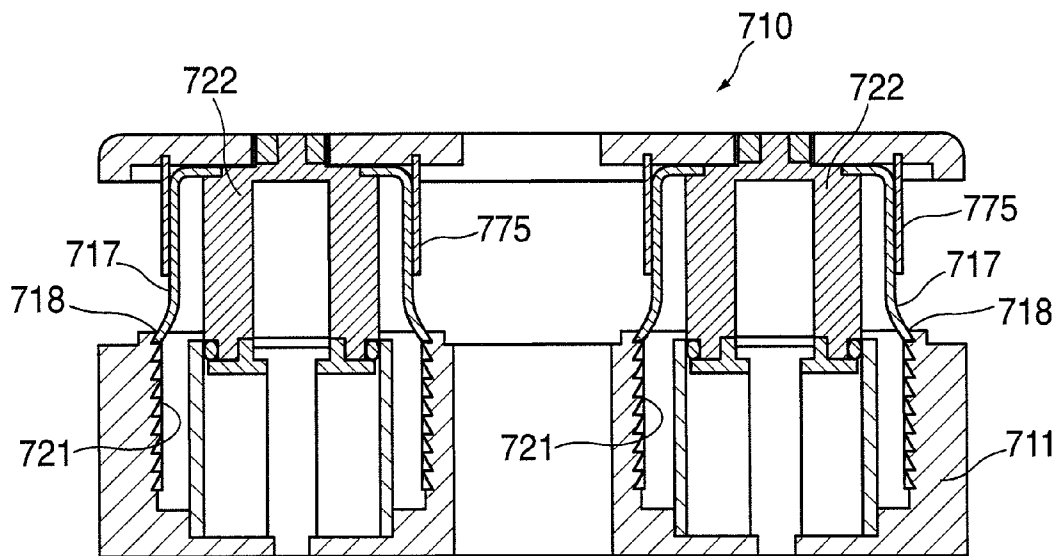

FIG. 19

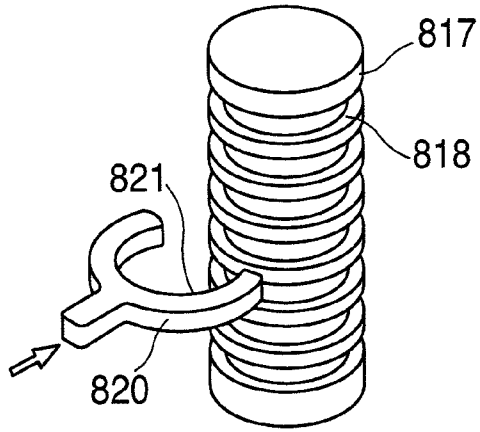

FIG. 20A

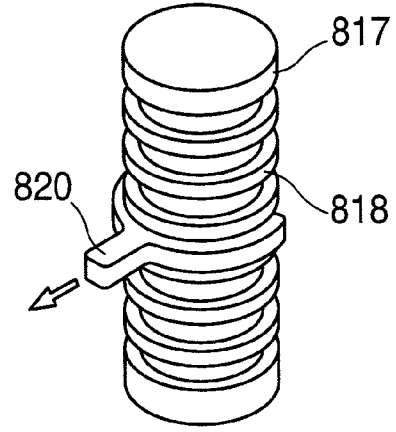

FIG. 20B

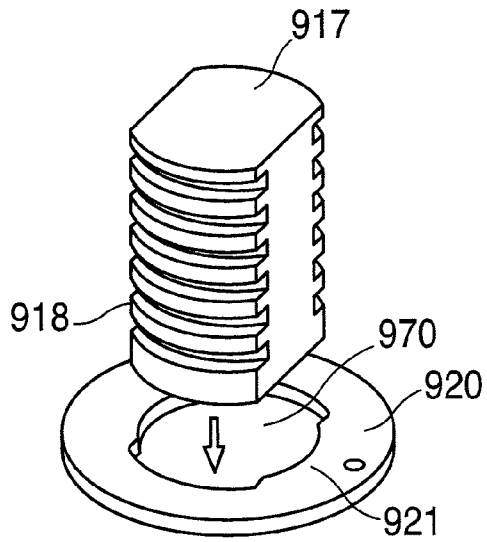

FIG. 21A

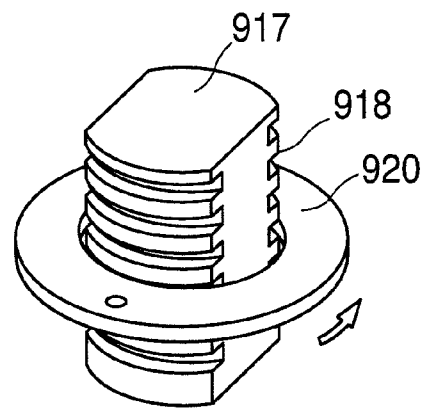

FIG. 21B

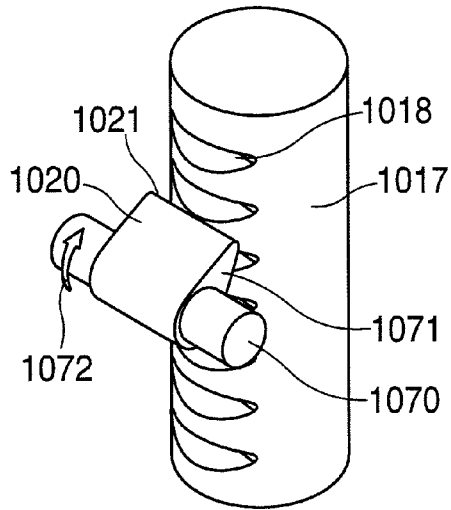

FIG. 22

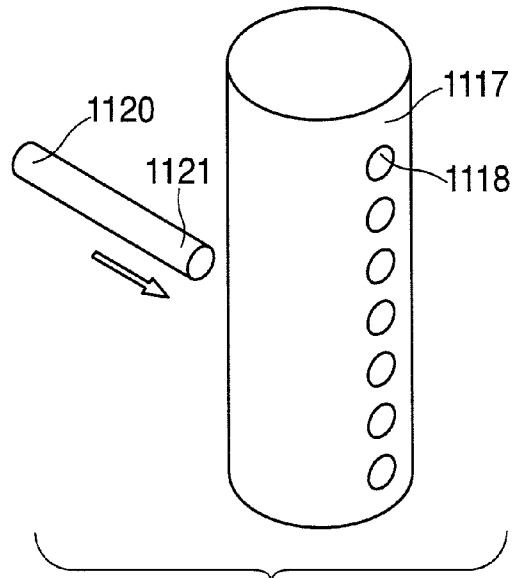

FIG. 23

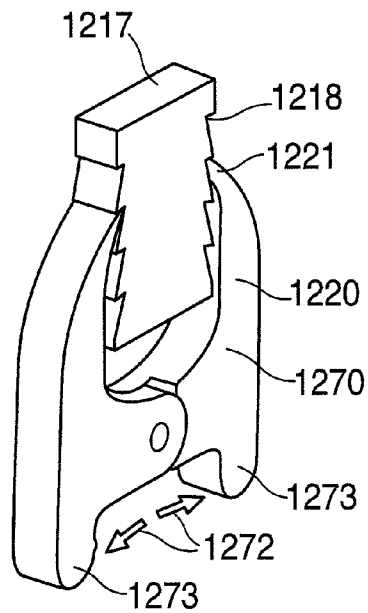

FIG. 24

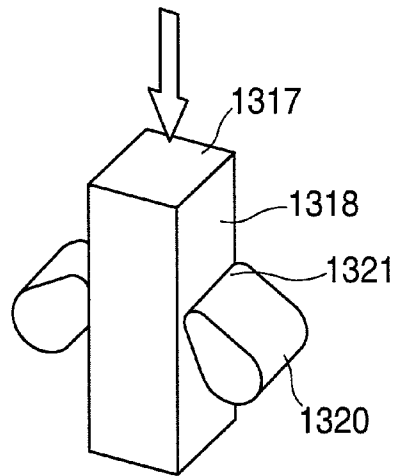

FIG. 25

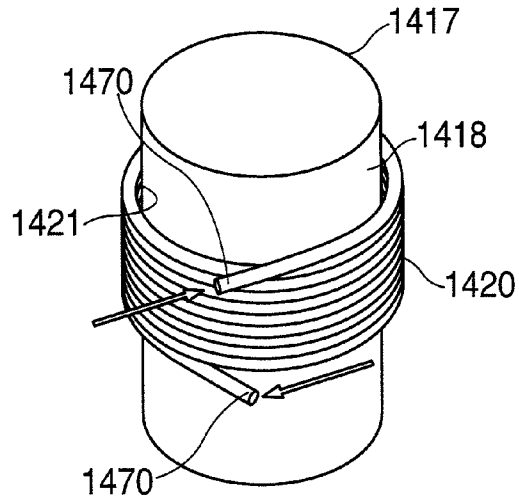

FIG. 26

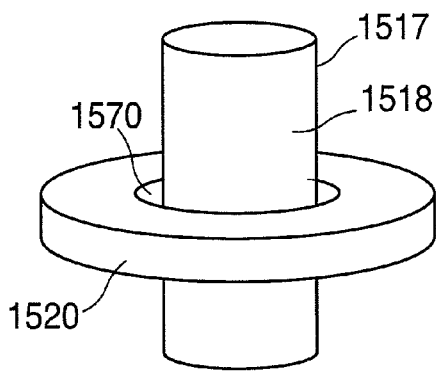

FIG. 27A

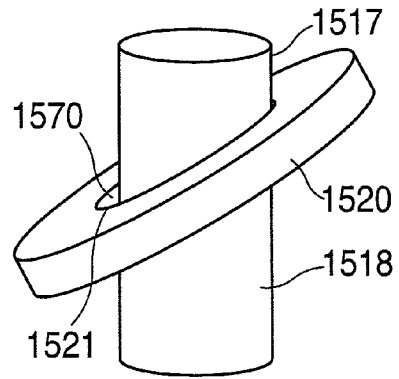
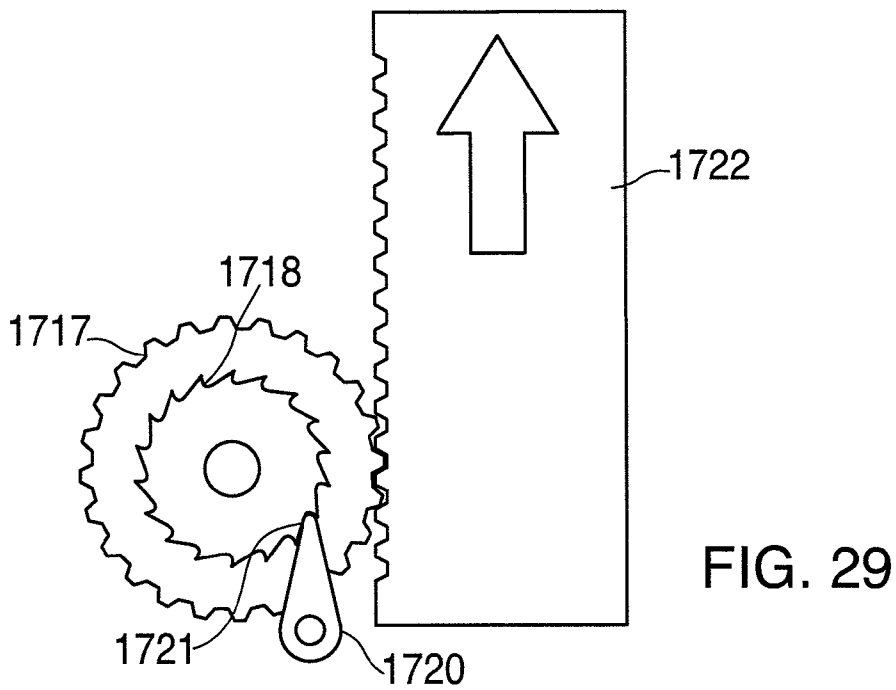
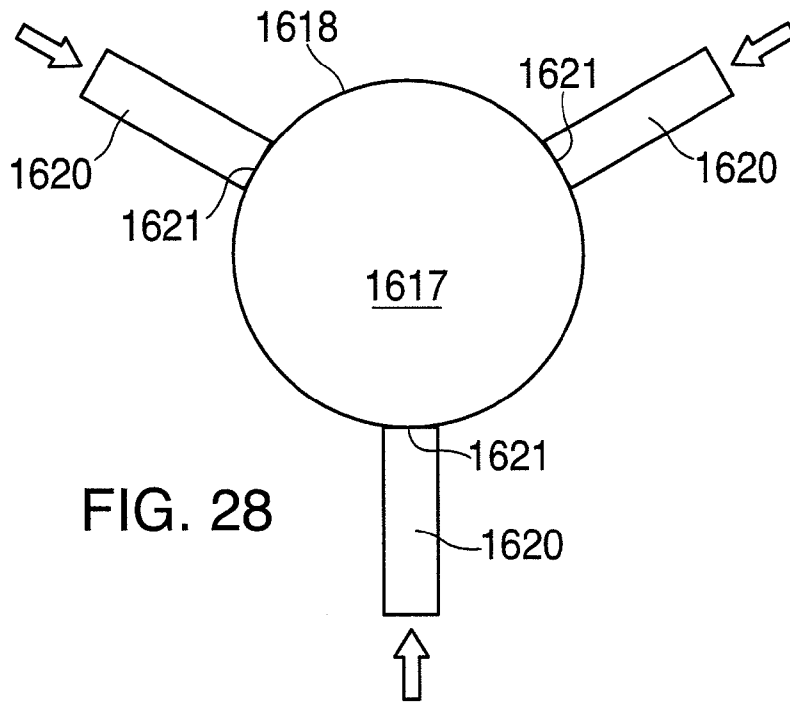

FIG. 27B





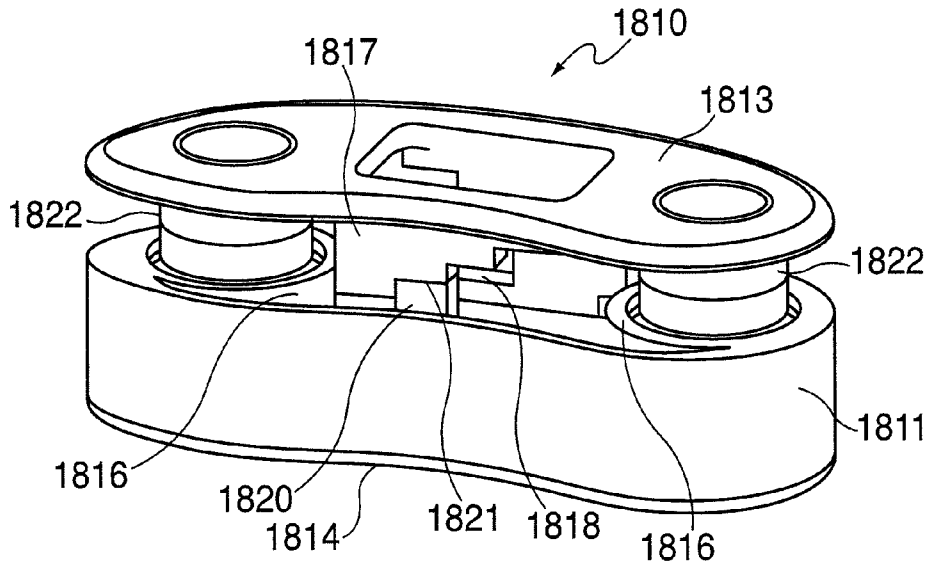

FIG. 30

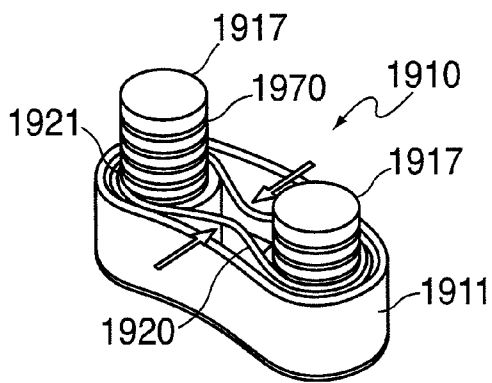

FIG. 31A

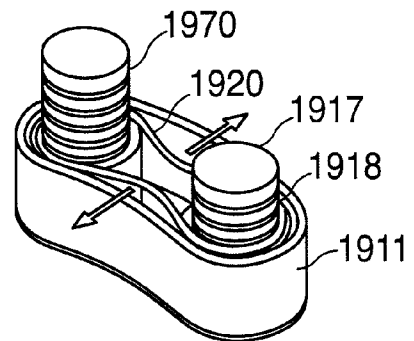

FIG. 31B

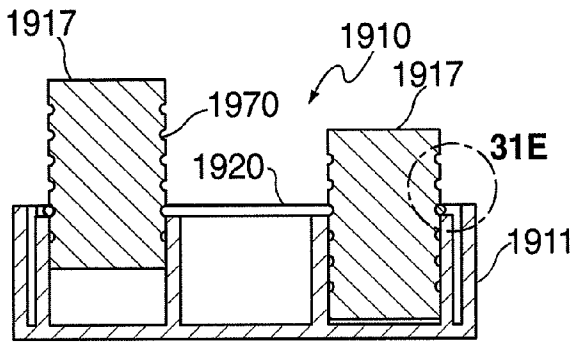

FIG. 31C

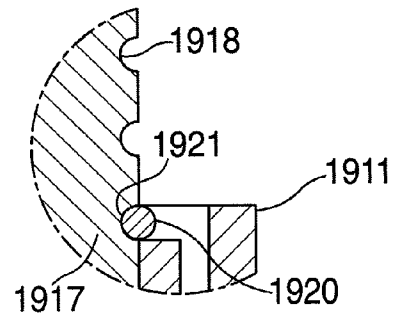

FIG. 31E

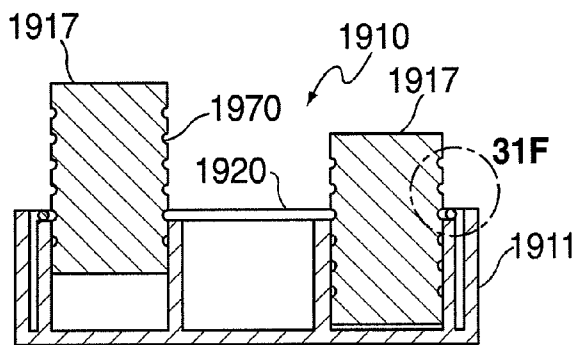

FIG. 31D

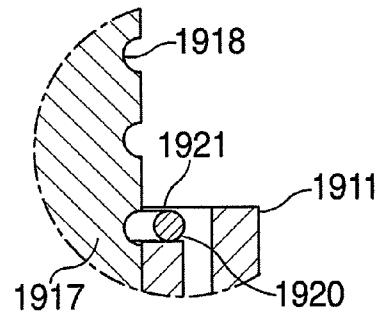

FIG. 31F

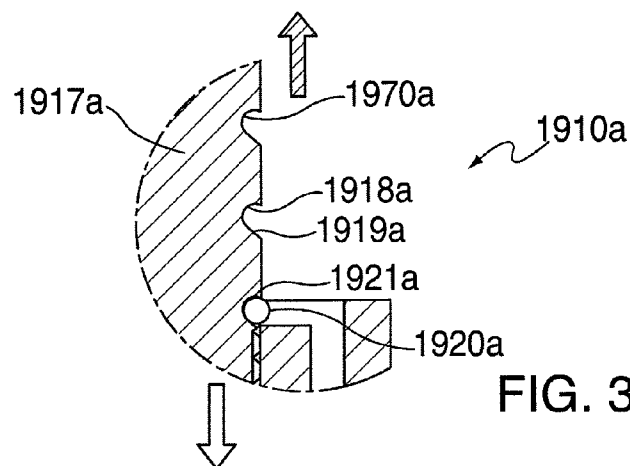

FIG. 31G

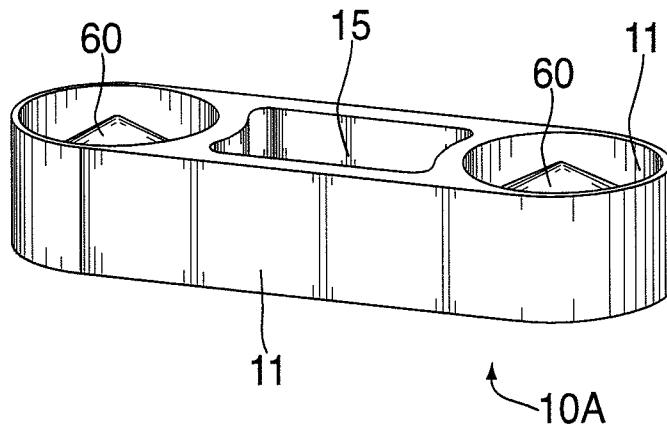

FIG. 32A

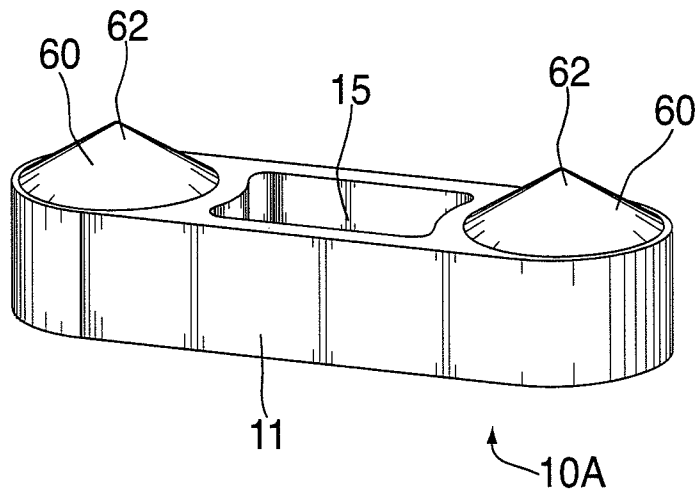

FIG. 32B

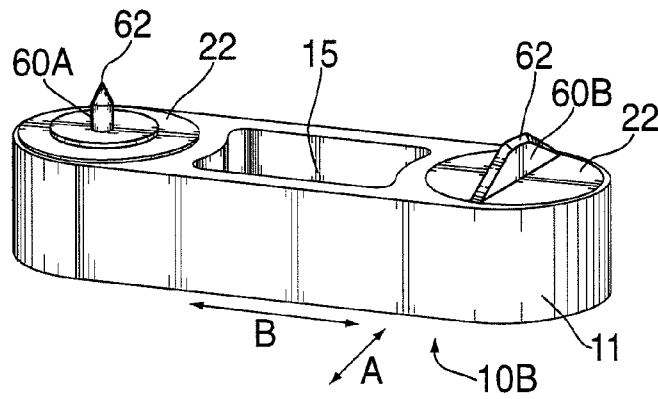

FIG. 33A

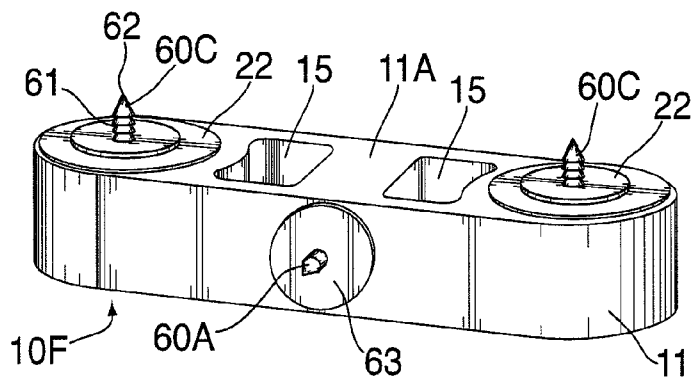

FIG. 33B

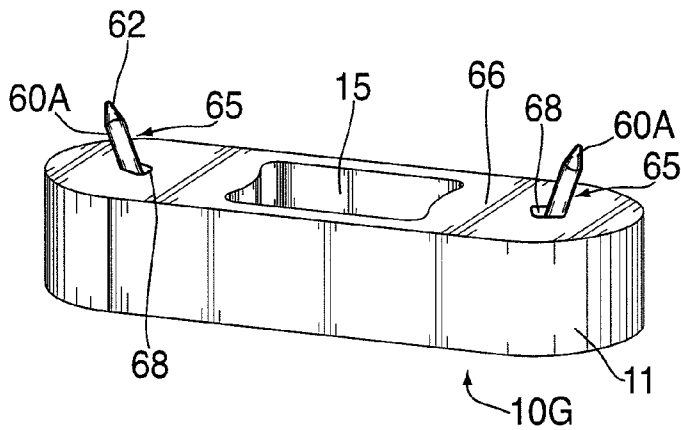

FIG. 33C

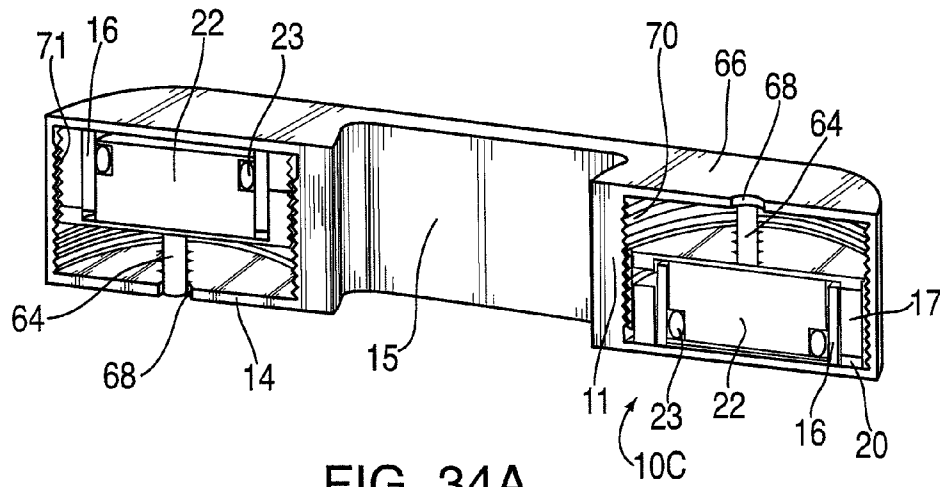

FIG. 34A

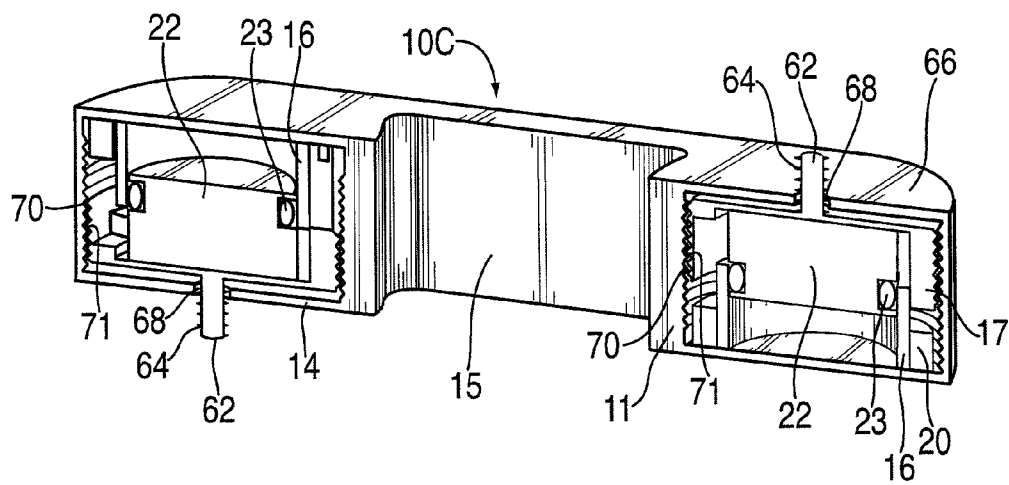

FIG. 34B

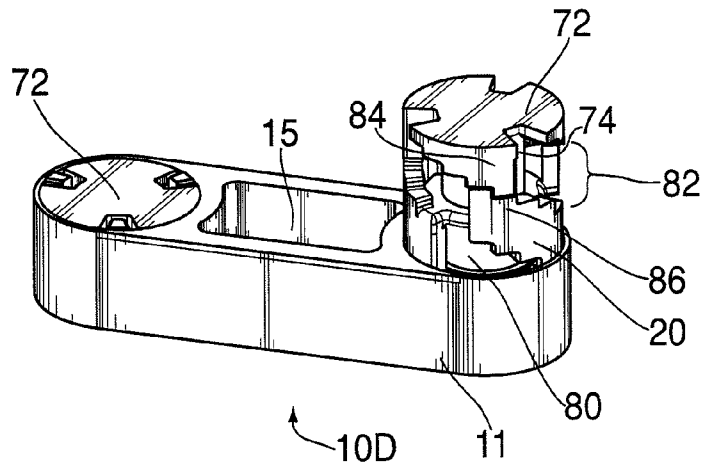

FIG. 35A

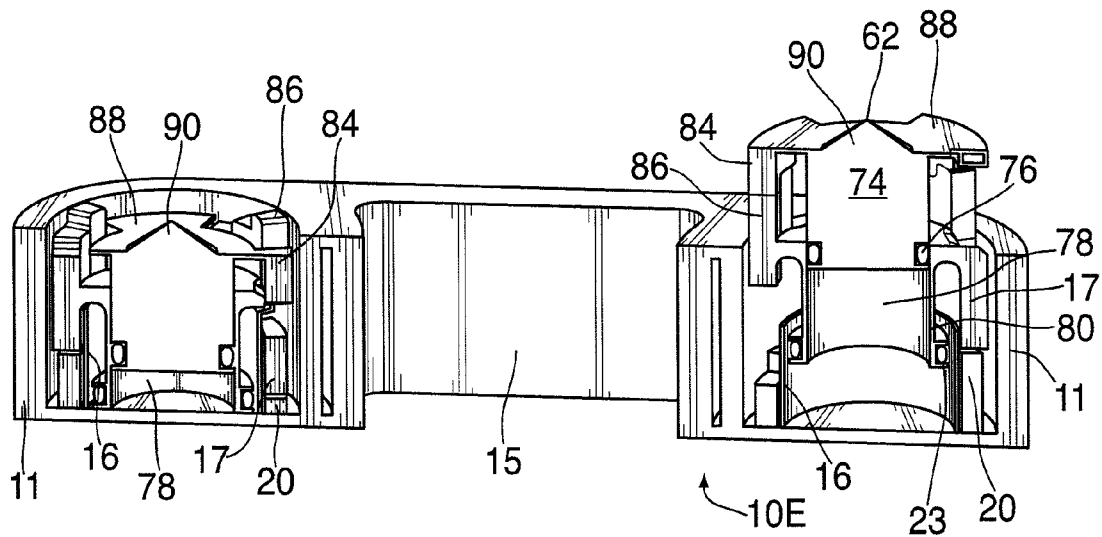

FIG. 35B

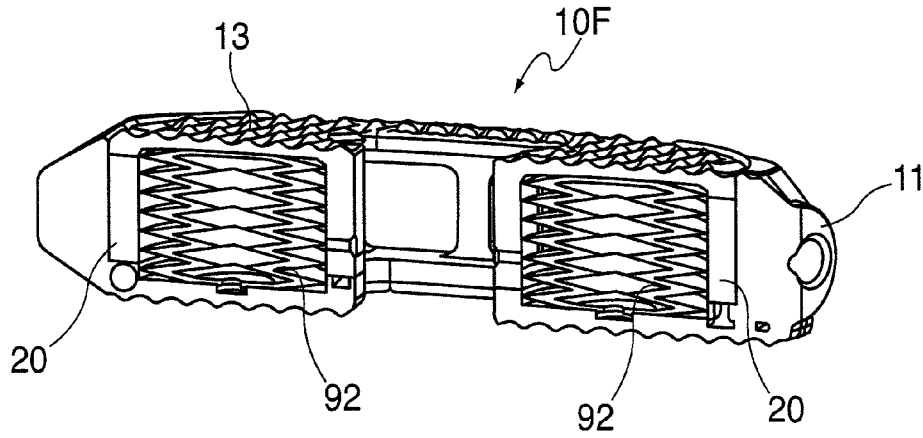

FIG. 36A

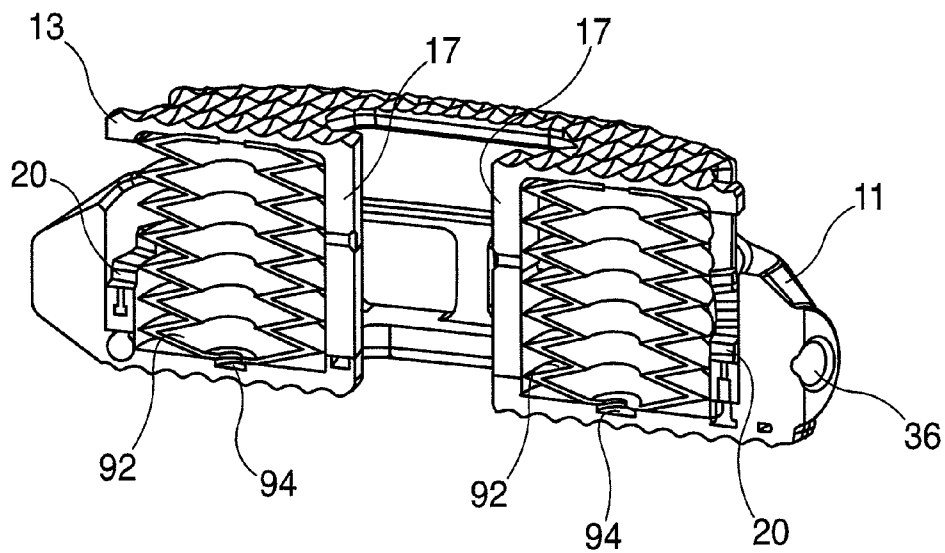

FIG. 36B

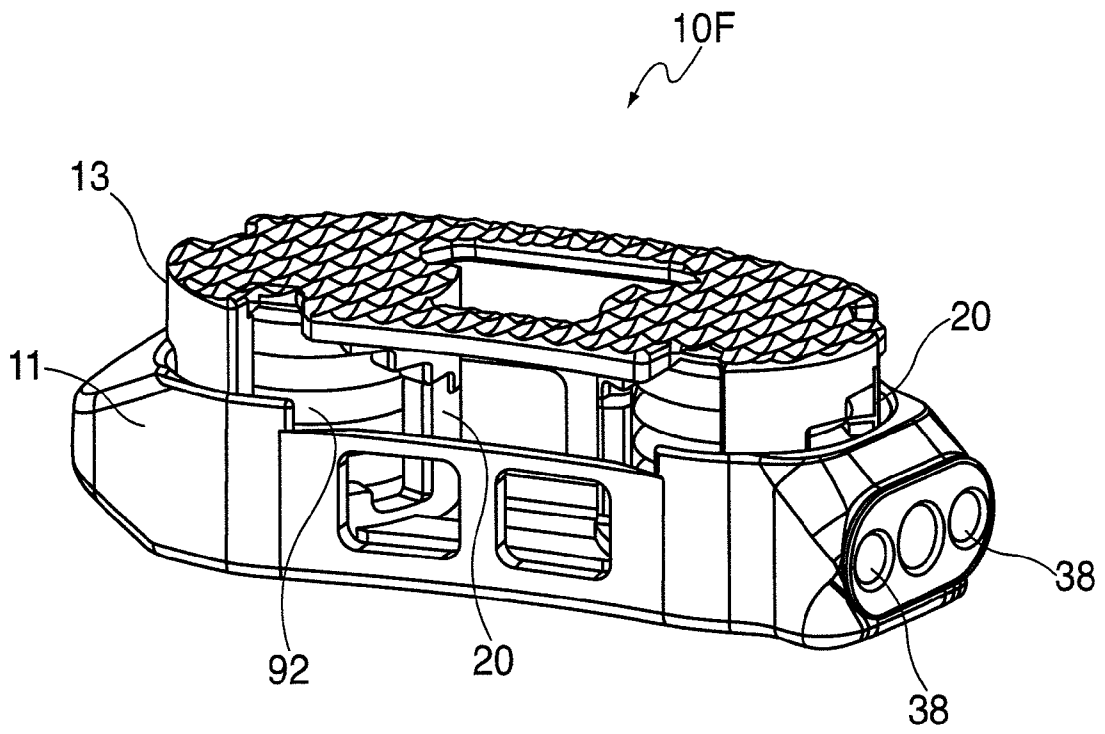

FIG. 36C



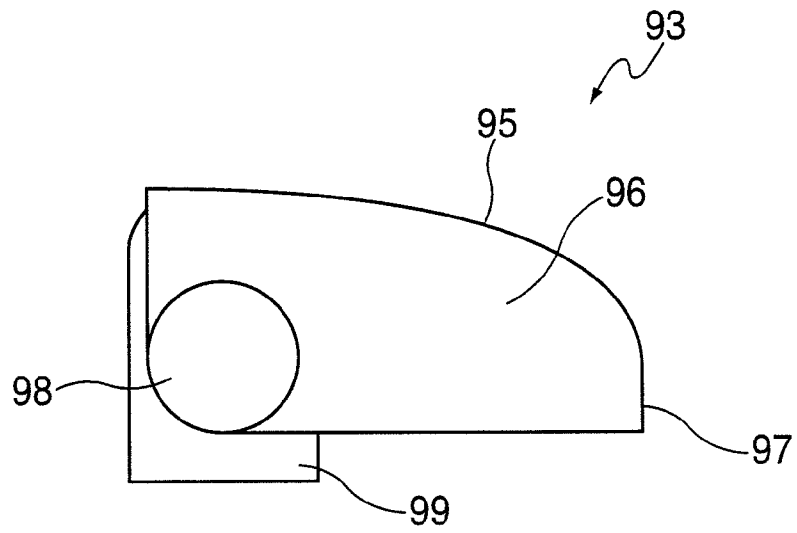

FIG. 37A

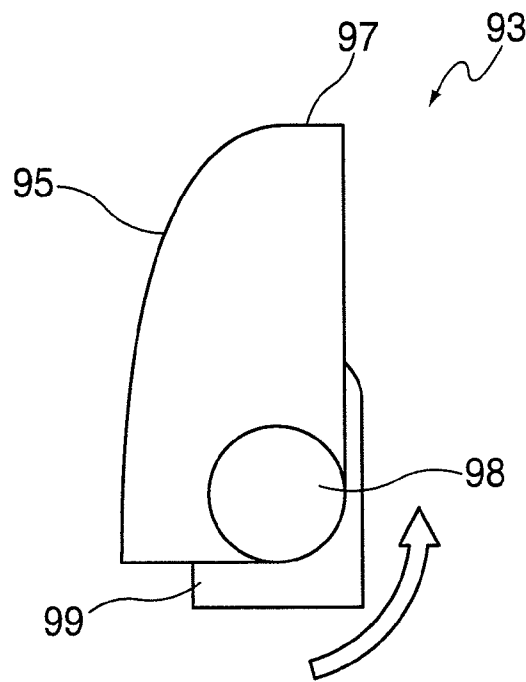

FIG. 37B

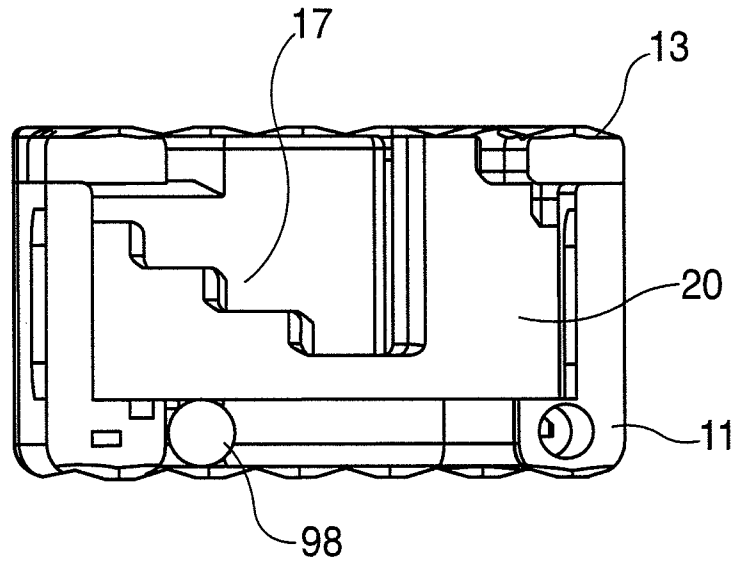

FIG. 38A

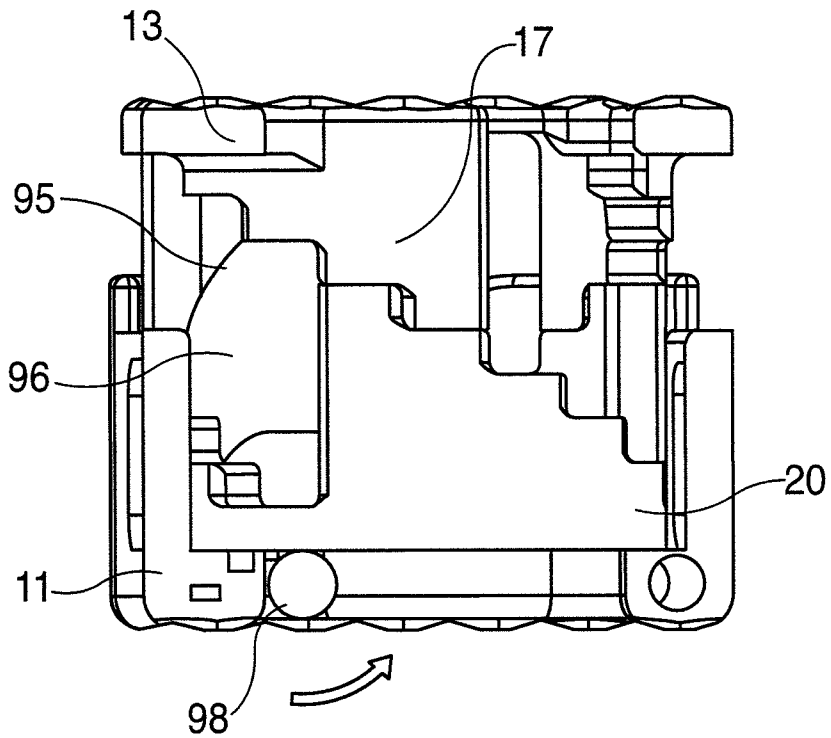

FIG. 38B

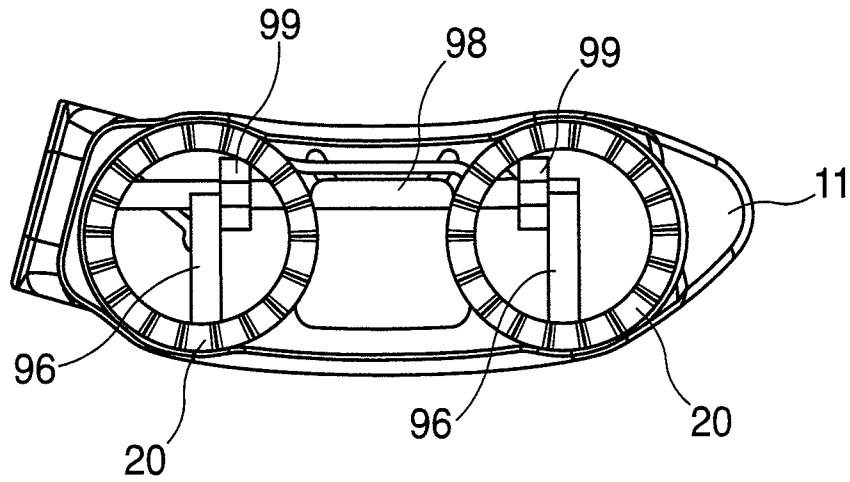

FIG. 39A

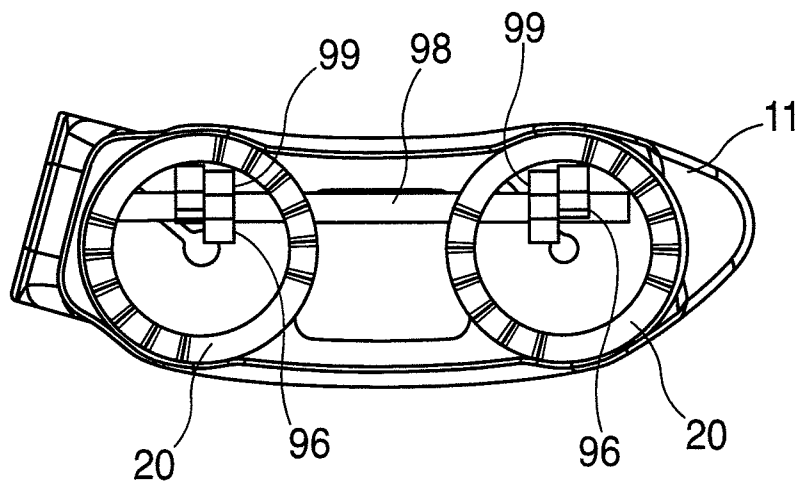

FIG. 39B

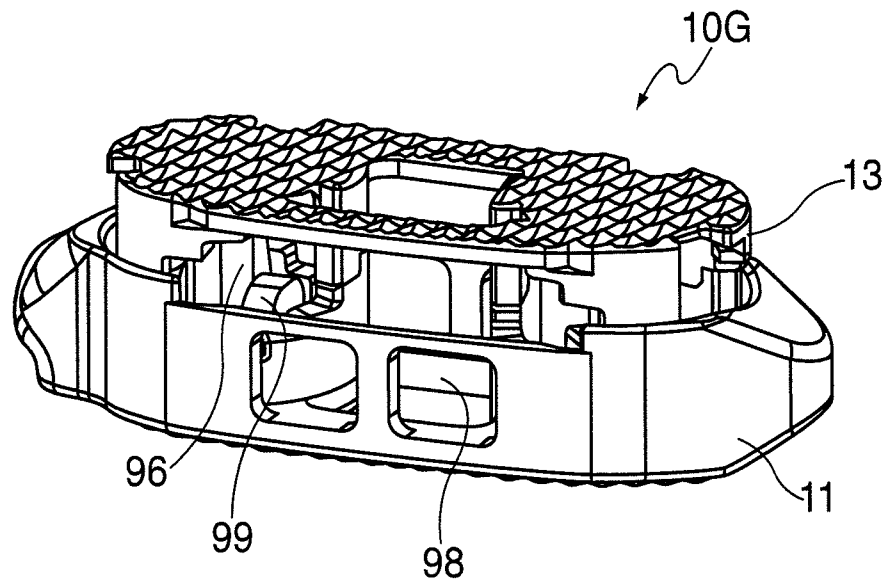

FIG. 40

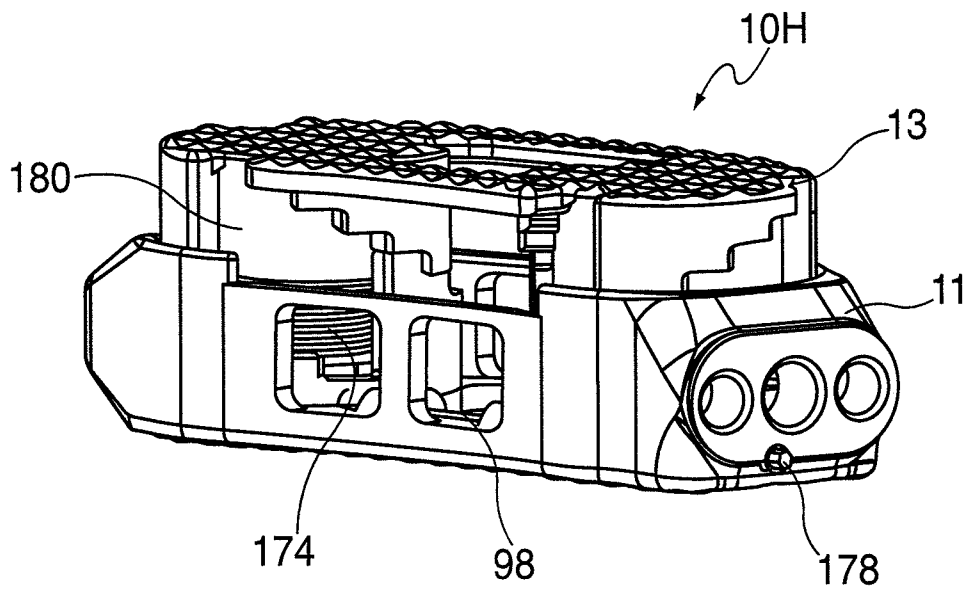

FIG. 41

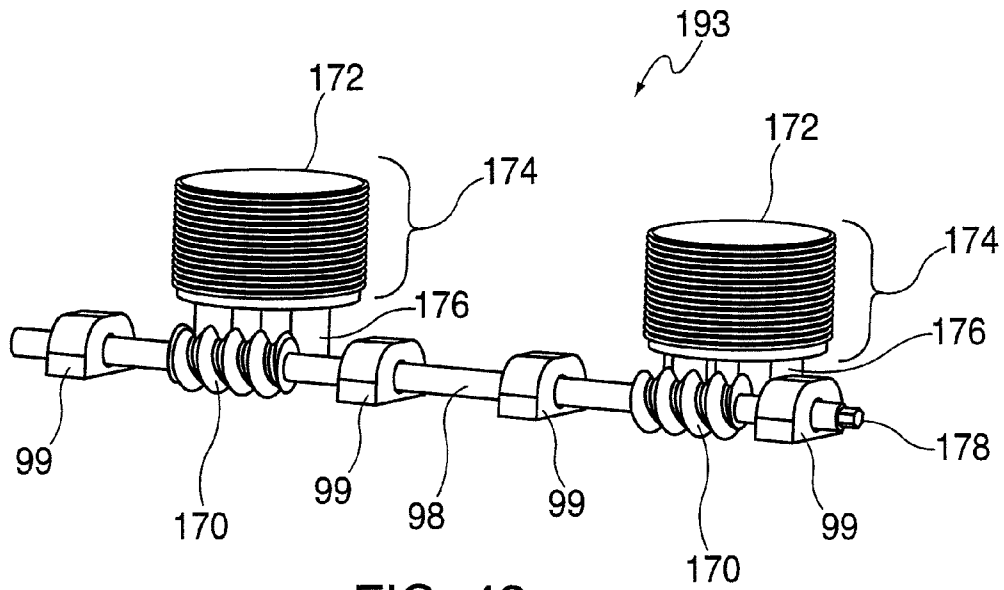

FIG. 42

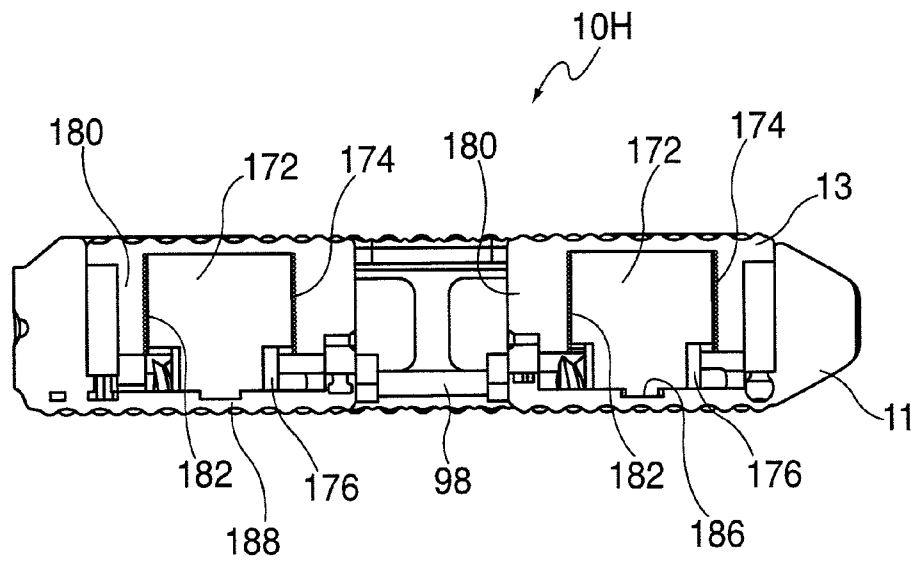

FIG. 43A

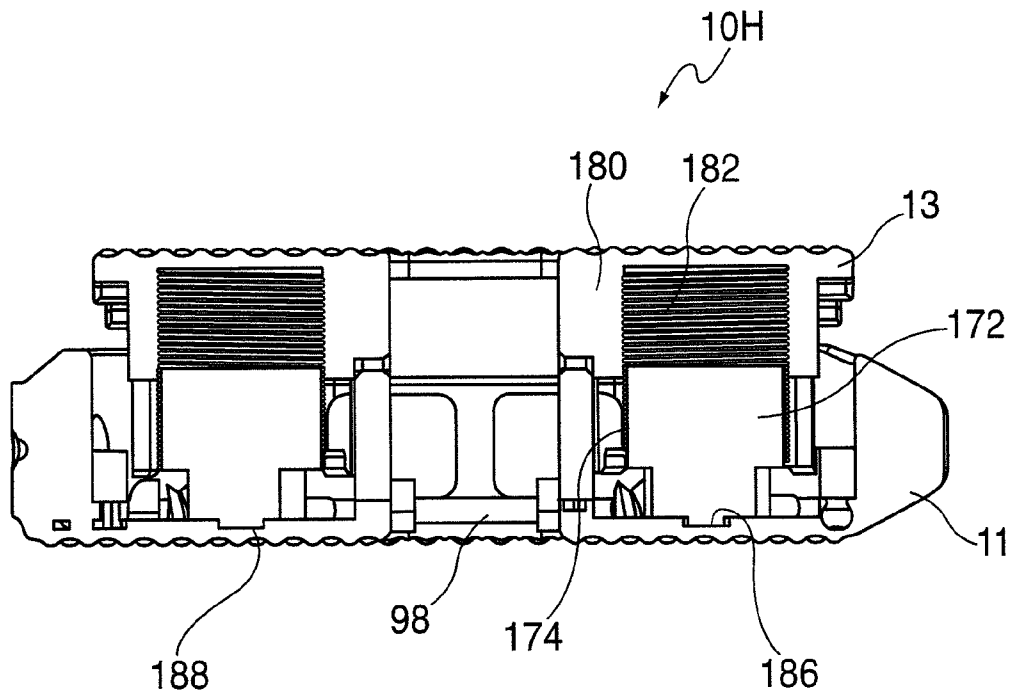

FIG. 43B

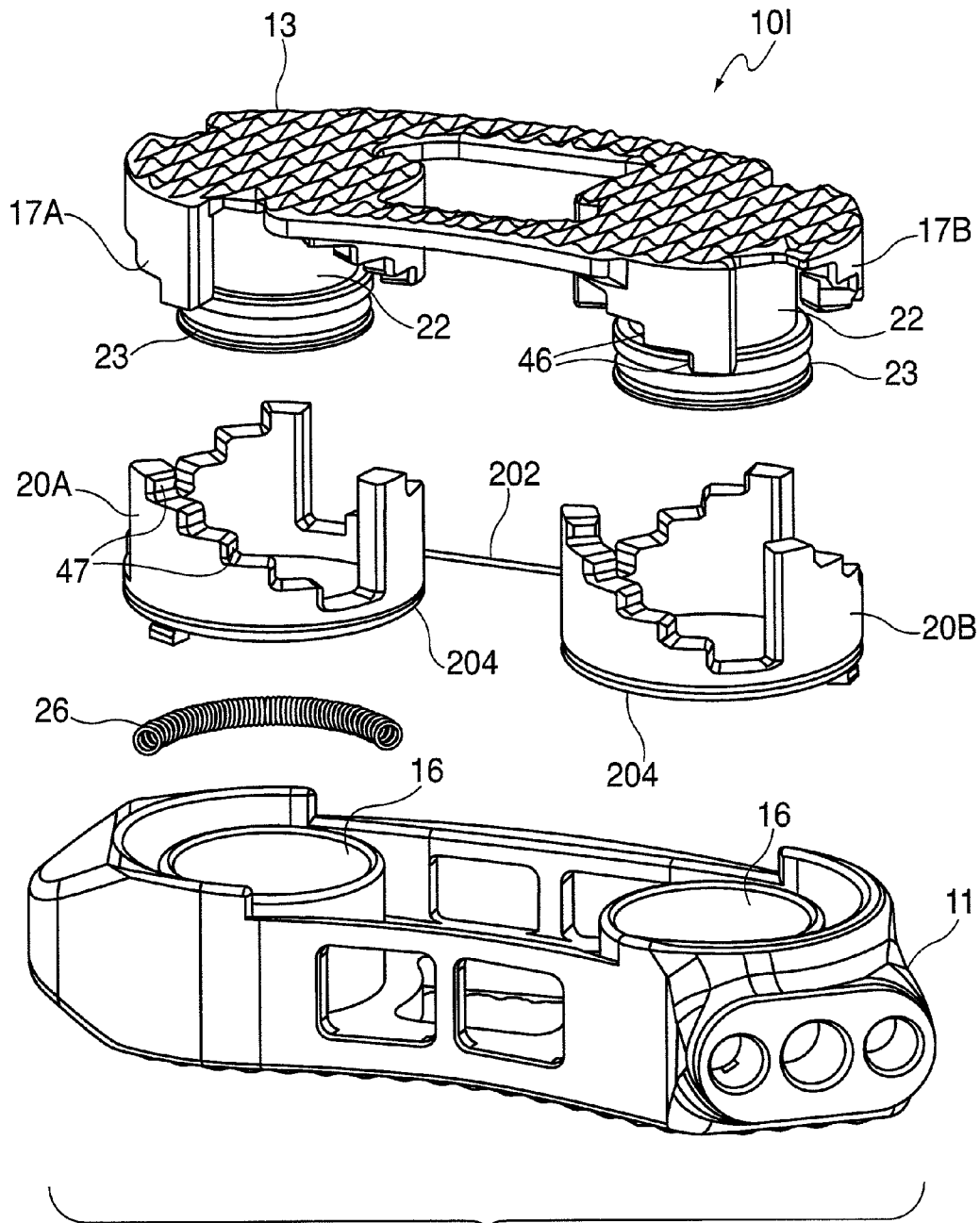

FIG. 44

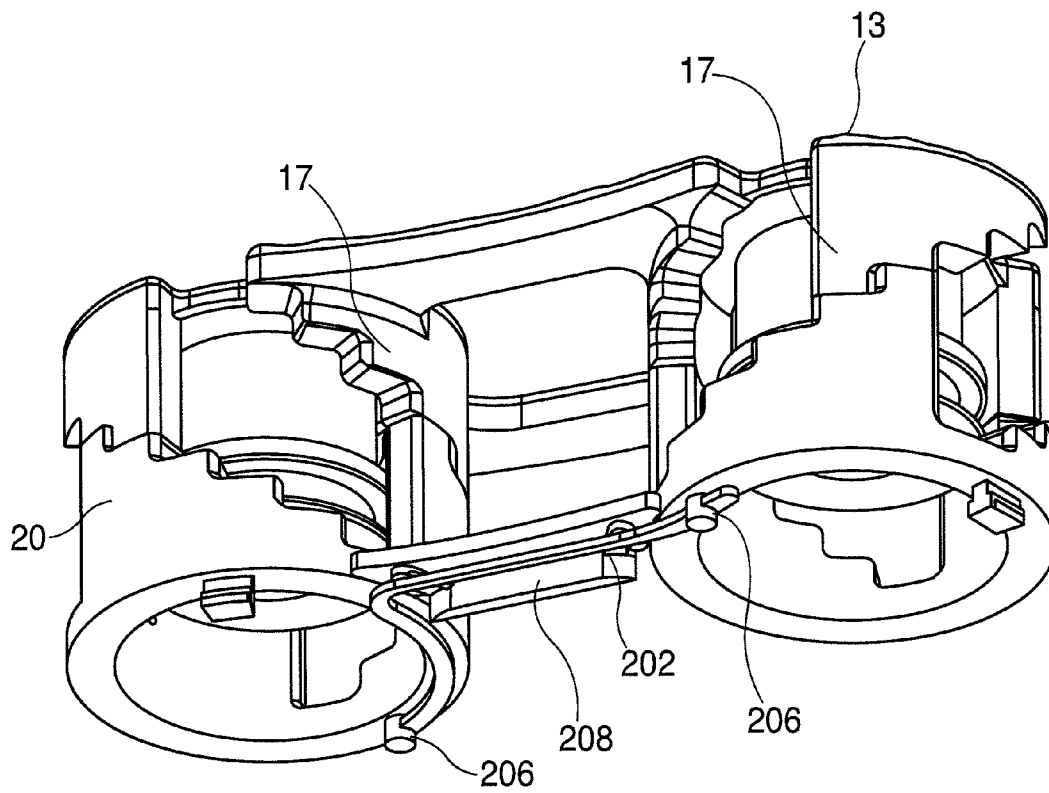

FIG. 45A



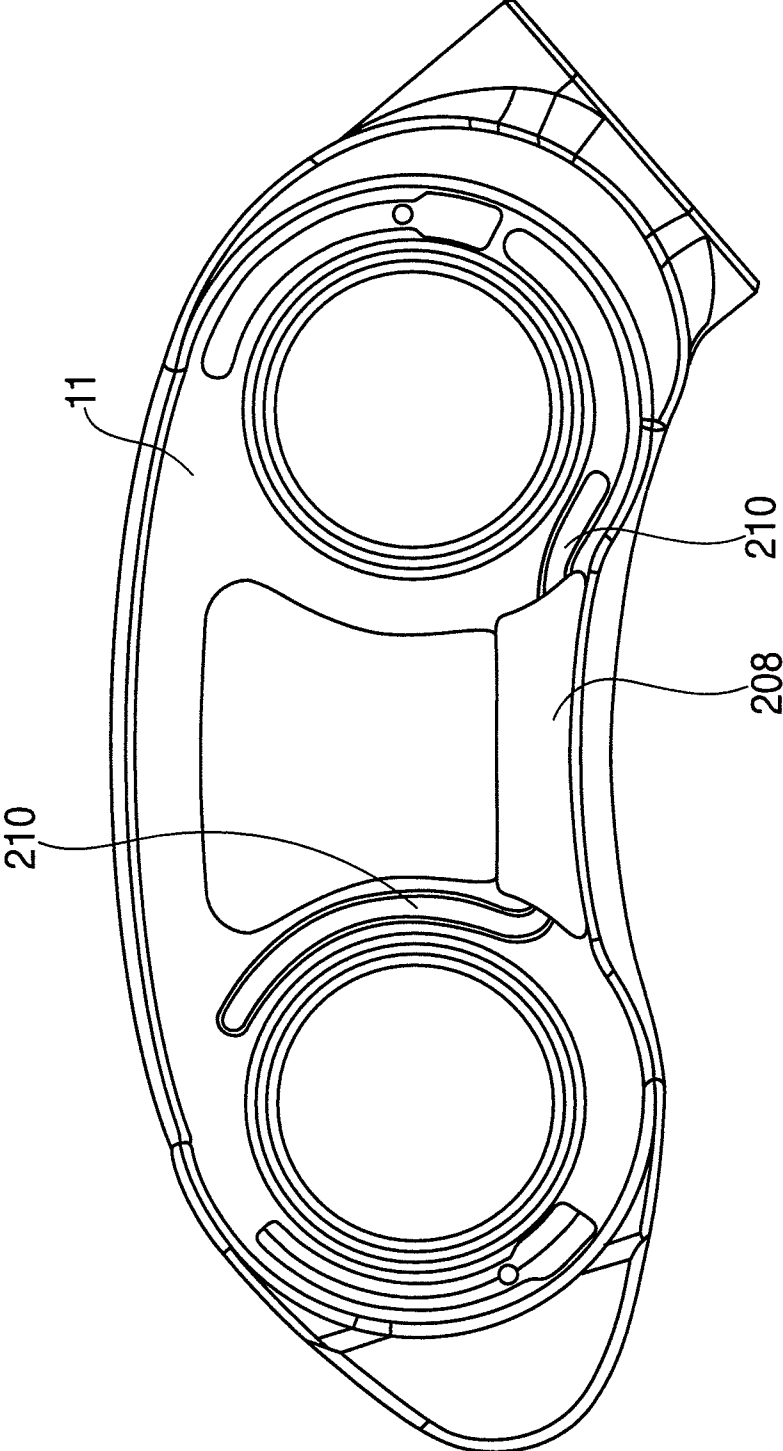

FIG. 45B

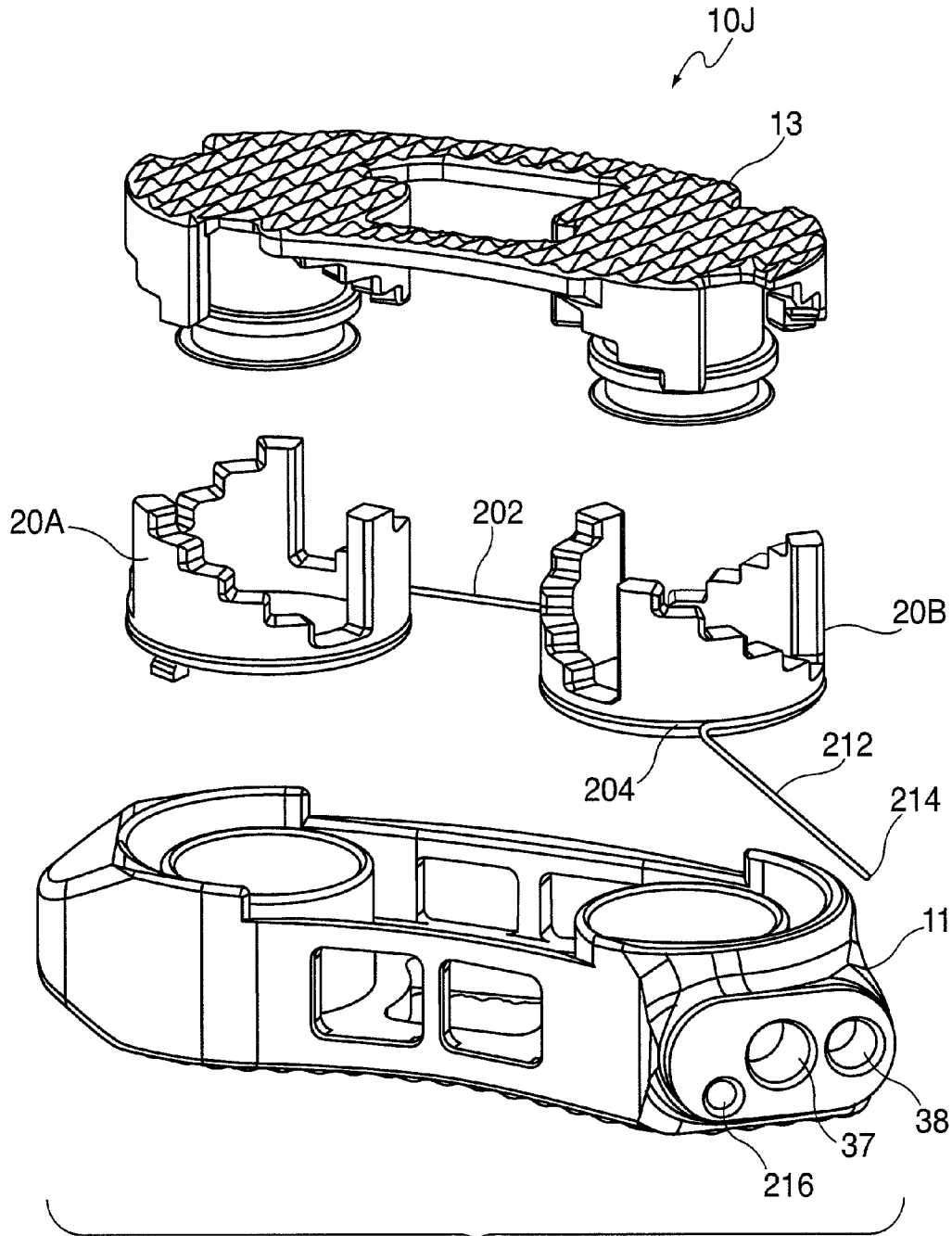

FIG. 46A

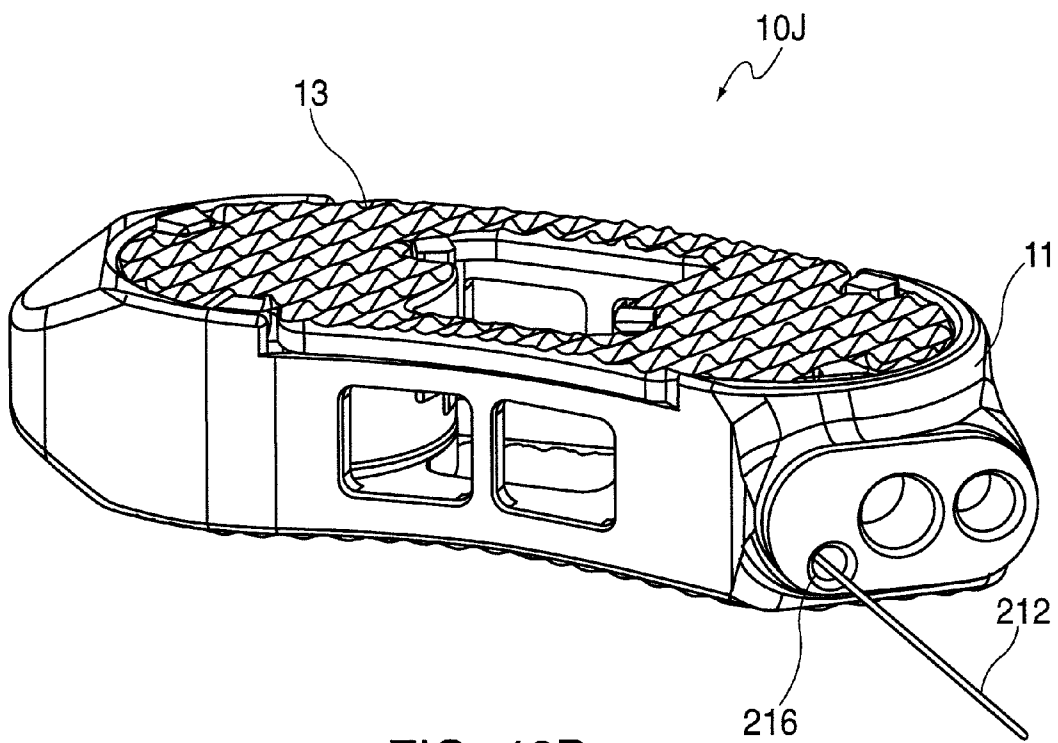

FIG. 46B

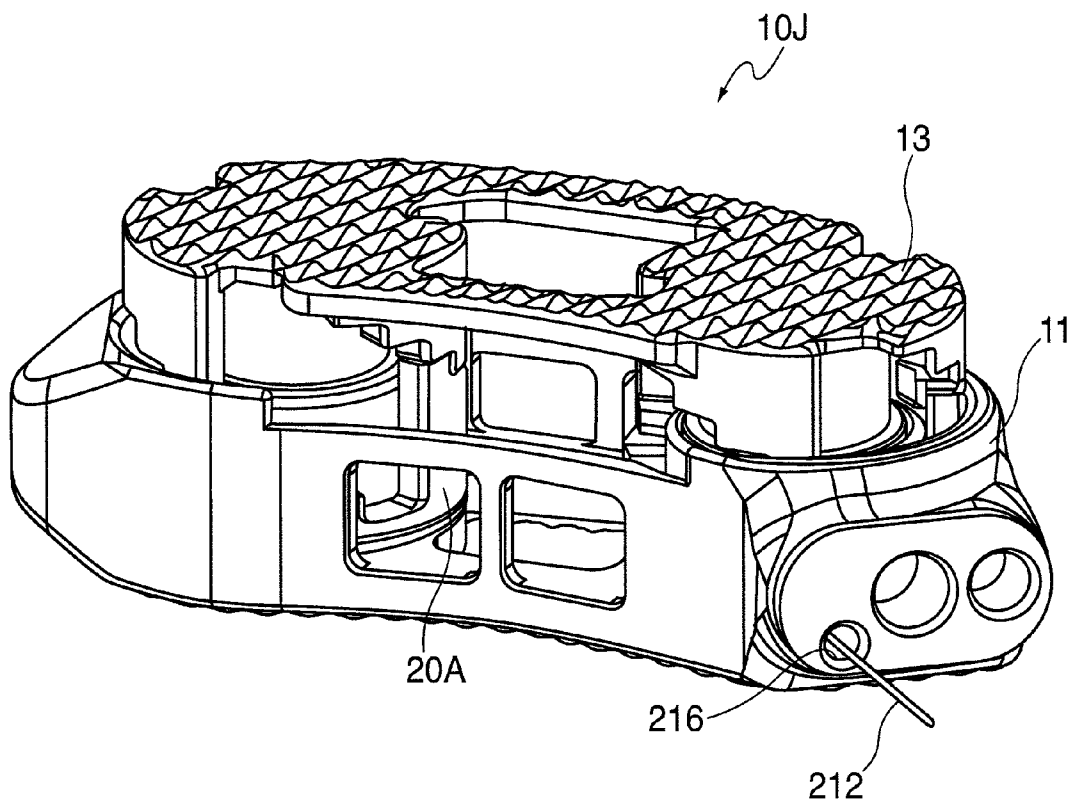

FIG. 46C

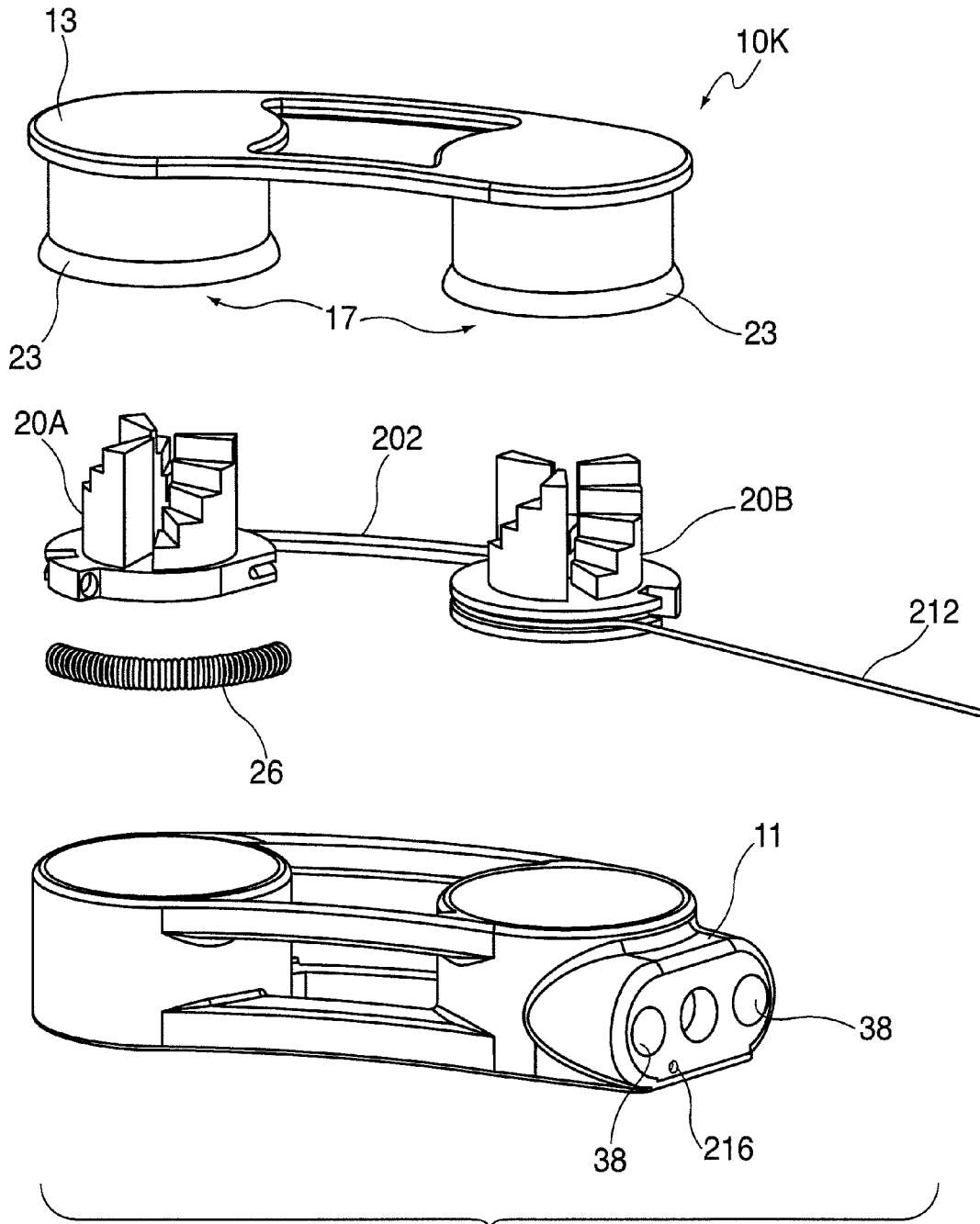

FIG. 47

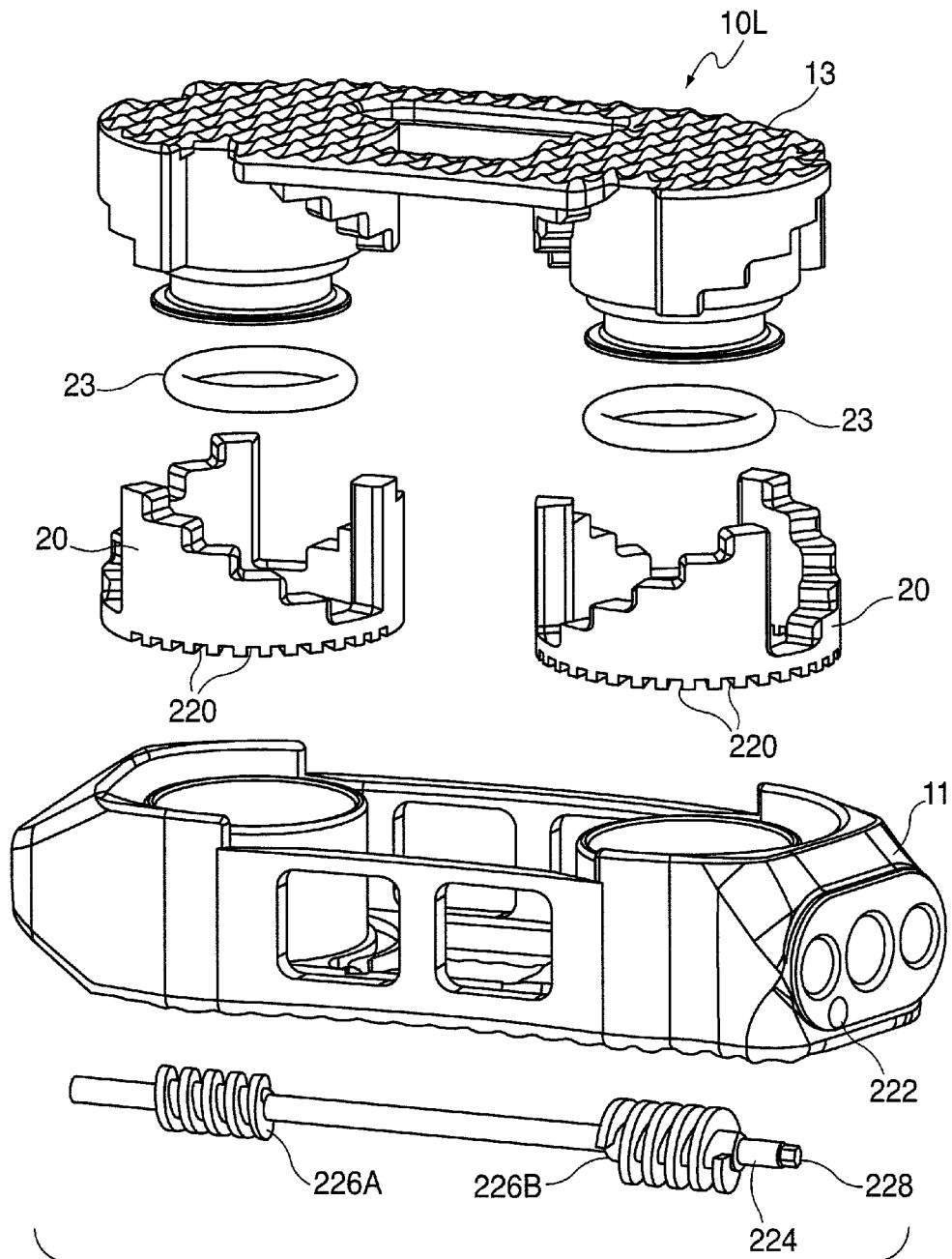

FIG. 48

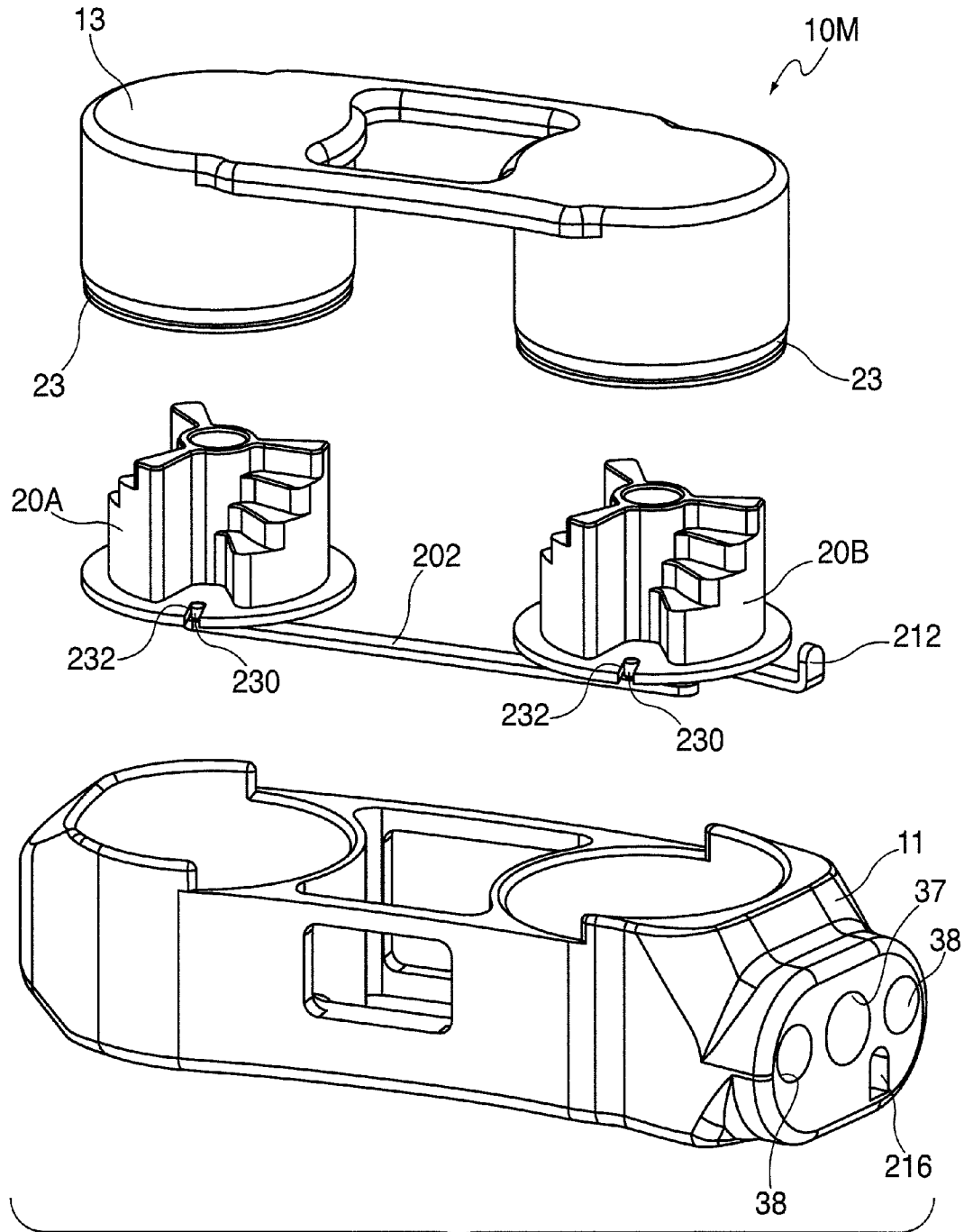

FIG. 49

## ADJUSTABLE DISTRACTION CAGE WITH LINKED LOCKING MECHANISMS

### RELATED APPLICATION DATA

This application is a continuation-in-part of International Application No. PCT/US2009/67446, designating the United States, filed Dec. 10, 2009, entitled "Lockable Expanding Spine Cage," and U.S. Nonprovisional patent application Ser. No. 12/380,840, filed on Mar. 4, 2009, entitled "Lockable Spinal Implant," which is a nonprovisional of U.S. Provisional Patent Application Ser. No. 61/201,518, filed on Dec. 10, 2008, entitled "Lockable Spinal Implant."

This application is also related to U.S. patent application Ser. No. 11/692,800, filed Mar. 28, 2007, entitled "Selectively Expanding Spine Cage, Hydraulically Controllable in Three Dimensions for Vertebral Body Replacement," which is a continuation-in-part of U.S. Nonprovisional patent application Ser. No. 11/535,432, filed Sep. 26, 2006, entitled "Selectively Expanding Spine Cage, Hydraulically Controllable in Three Dimensions for Enhanced Spinal Infusion," which is a nonprovisional of U.S. Provisional Patent Application Ser. No. 60/720,784, filed Sep. 26, 2005, entitled "Selectively Expanding Spine Cage, Hydraulically Controllable in Three Dimensions for Enhanced Spinal Infusion."

Each of the above listed applications is incorporated herein by reference in its entirety.

### FIELD OF THE INVENTION

The invention relates to devices and methods for stabilizing the vertebral motion segment. More specifically, the field of the invention relates to an expandable spinal implant with locking elements configured to lock the implant in an expanded configuration within an intervertebral space to provide controlled spinal correction in three dimensions for improved spinal intervertebral body distraction and fusion.

### BACKGROUND

A conventional spine cage or implant is characterized by a kidney bean shaped body which is typically inserted posteriorly through the neuroforamen of the distracted spine after a trial implant creates a pathway. Existing devices for interbody stabilization have important and significant limitations, including inability to expand and distract the end plates or to fix the device in place to prevent relative movement between the device and an adjacent vertebral body. Current devices for interbody stabilization include static spacers composed of titanium, PEEK, and high performance thermoplastic polymer produced by VICTREX, (Victrex USA Inc, 3A Caledon Court, Greenville, S.C. 29615), carbon fiber, or resorbable polymers. Moreover, current interbody spacers do not maintain interbody lordosis and can contribute to the formation of a straight or even kyphotic segment and the clinical problem of "flatback syndrome." Separation of vertebral end plates increases space available for the neural elements, specifically the neural foramen. Existing static cages do not reliably improve space for the neural elements. Therefore, what is needed is a spinal implant that will provide space for the neural elements posteriorly between the vertebral bodies, or at least maintain the natural bone contours to avoid neuropraxia (nerve stretch) or encroachment.

Conventional devices for intervertebral body stabilization include poor interface between bone and the biomaterial of the device. Conventional static interbody spacers form a weak interface between bone and biomaterial. Although the surface

of such implants is typically provided with a series of ridges or coated with hydroxyapatite, the ridges may be in parallel with applied horizontal vectors or side-to-side motion. That is, the ridges or coatings on the implant offer little resistance to movement applied to either side of the end plates. Thus, nonunion is common in allograft, titanium and polymer spacers, due to motion between the implant and host bone.

### SUMMARY OF THE DISCLOSURE

This invention is generally directed to a spinal implant for insertion between superior and second vertebral end plates after partial or total removal of a spinal disc. The spinal implant embodying features of the invention has a contracted configuration for easy installation between adjacent vertebral bodies and an expanded configuration to support the vertebrae in a desirable position. More specifically, the implant has a plurality of inter-engagable elements which locks the implant in an expanded configuration to hold the vertebral or joint sections in the desired positions.

The invention is particularly directed to a spinal implant suitable for placement between superior and inferior vertebral bodies. The spinal implant has a first member or top plate for engaging an end of the superior vertebral body and a second member or base for engaging an end of the inferior vertebral body and has one or more extendable support elements preferably with one or more top end plates that engage vertebral bodies in the expanded configuration. The one or more extendable support elements have a first contracted configuration to facilitate deployment of the implant between the superior and inferior vertebral bodies and safely past sensitive neural elements and a second or an extended configuration to engage the end plates of the vertebral bodies. The implant has a locking system with linked locking elements that mechanically engage or interlock with the extendable support element or the first member to lock the implant between the superior and inferior vertebral bodies in an expanded configuration.

The extendable support element(s) may be extended in a variety of ways such as with fluid pressure, e.g. hydraulic fluid or gas, by mechanical force, such as a threaded connection with a rotating driving member or other suitable means. Fluidic displacement is preferred. The extendable support element(s) are disposed in cylinders which support and guide the extendable support elements when they are extended. However, the locking system is separate from the extendable support member and cylinder receiving the supporter member, although the extending support member may initiate the locking system and the support member and cylinder may have lock support members attached thereto.

In one exemplary system, the spinal implant having features of the invention comprises an inferior pressure applying member or base with a first bone engaging surface, one or more extendable support members cooperating with the base and a superior pressure applying member such as a top end plate with a second bone engaging surface that is coupled to the at least one extendable member. The spinal implant preferably has a plurality of engaging locking elements that are configured to independently lock one or more of the extendable support members or pressure applying members in an extended configuration to thereby provide desired disc height between adjacent vertebrae.

The spinal implant or selectively expanding spine cage (SEC) embodying features of the invention is particularly suitable for posterior or transforaminal insertion between superior and inferior vertebral end plates as described in copending application Ser. No. 11/535,432, filed Sep. 26, 2006, and Ser. No. 11/692,800, filed Mar. 28, 2007. The



implant has a contracted or unexpanded configuration which allows easy deployment and is typically about 0.5 to about 1 cm in maximum short transverse dimension so as to enable minimally invasive insertion posteriorly between vertebral pedicles through a working space of approximately 1 cm in diameter.

In one exemplary embodiment, the spinal implant for placement between adjacent vertebral bodies as described above has an upper locking member with stepped supporting surfaces on the underside thereof and a lower locking member with stepped supporting surfaces on the top side thereof which are configured to engage the stepped supporting surface of the upper locking member to lock the implant in an extended configuration. Extension of the expandable members, such as bellows or pistons; or other appropriately sized mechanisms, such as cams or screws, to raise the superior pressure applying member increases longitudinal spacing between the upper and lower locking members. Relative motion, rotational or linear, between the upper and lower locking members causes the stepped supporting surfaces of the lower locking members and the stepped supporting surfaces of the upper locking members to re-engage to fix the locking members in an increased spaced apart relationship and thereby lock the implant in the extended configuration.

Since the vertebral end plates are held together at one end by a ligament much like a clamshell, as the implant expands against the vertebral end plates, the amount of vertical expansion can be adjusted to create the desired anterior/posterior correction angle.

A minimally invasive downsized insertion tool, such as described in the above referenced applications, both inserts the unexpanded implant posteriorly and provides the hydraulic or mechanical lines communicating with the interior of the implant. The insertion tool may also provide a line for communicating the liquid or slurry bone graft material into the intervertebral space for subsequent fusion. Advantageously, hydraulic lines are small size tubing to allow for high hydraulic pressure without danger of the lines bursting.

Due to the mechanical advantage provided by a hydraulic system or a proximally operated mechanical system, the implant has minimized size and diameter in its unexpanded state that is smaller than the diameter of a prepared neuroforamen. The implant thus can be inserted transforaminally and engaged between the end plates of the adjacent vertebra to effectively distract the intervertebral area, restore space for neural elements, stabilize the motion segment and eliminate pathologic segmental motion. The implant enhances spine arthrodesis by creating a rigid spine segment.

The implant is preferably provided with a hollow interior to enable a comparatively large quantity of bone growth conductive or inductive agents to be contained therein that through openings communicate directly to adjacent bone. Importantly, this results in fixation forces greater than adjacent bone and soft tissue failure forces. The implant can be used to promote fusion, and/or to correct deformities such as scoliosis, kyphosis, and spondylolisthesis.

The clinical goals of the implant and the method for its insertion provide a minimally invasive risk of trauma to nerve roots, reduce pain, improve function, and permit early mobilization of the patient after fusion surgery. The fixation elements maintain the implant in a desired position until healing (fusion or arthrodesis) occurs. At this point, the implant is incorporated inside bone and its role becomes quiescent.

Thus, a feature of the invention is that an implant can be inserted posteriorly between vertebral pedicles in only a working space of about 1/2 cm and then be expanded from about 100% to about 200%, typically about 160%, of its

original insertion size and locked in that position to provide a closely controlled full range of permanent spinal correction in three dimensions. These and other advantages of the invention will become more apparent from the following detailed description and the accompanying exemplary drawings.

In other embodiments of the invention, extendable, locking, bone engaging anchors are provided to ensure that the implant is positively engaged with the bone after insertion.

In one implementation, the present disclosure is directed to a lockable, extendable spinal implant for placement between first and second vertebral bodies. The implant includes: first and second bone engaging members each having a surface configured to respectively engage opposed first and second vertebral bodies; extension means acting between the first and second bone engaging members to control extension of the bone engaging members between contracted and extended configurations; first and second fixed lock members fixed to one of the first and second bone engaging members and extending towards the opposite bone engaging member, the fixed lock members being spaced apart and each having a fixed locking surface; first and second moveable lock members captured between the first and second bone engaging members for cooperation with the fixed lock members, each moveable lock member having a moveable locking surface configured to engage an opposed fixed locking surface on one the fixed lock member to prevent contraction of the extension means; a locking actuator configured to engage the moveable locking surfaces with the fixed locking surfaces; and a link member operatively connected between the first and second moveable lock members to coordinate movement therebetween.

In another implementation, the present disclosure is directed to a lockable, extendable spinal implant for placement between first and second vertebral bodies. The implant includes: first and second bone engaging members each having a surface configured to respectively engage opposed first and second vertebral bodies; first and second pistons disposed on one the bone engaging member and cooperating with mating cylinders disposed on the opposite bone engaging member, the pistons moveable between a contracted configuration within the cylinders and an extended configuration extending from the cylinders; first and second arcuate, fixed lock members, each having a fixed locking surface, mounted to one of the bone engaging members, each disposed around one the piston, the fixed lock members extending towards the opposite bone engaging member; first and second moveable lock members, each formed around one the cylinder for cooperation with the fixed lock members, each moveable lock member having a moveable locking surface configured to engage an opposed fixed locking surface on one the fixed lock member to prevent contraction of the extension means; at least one biasing element acting on at least one the moveable lock member to bias the member into engagement with its associated fixed lock member; and a link member operatively connected between the first and second moveable lock members to coordinate movement therebetween and force the other moveable lock member into engagement with its associated fixed lock.

In still another implementation, the present disclosure is directed to a lockable, extendable spinal implant for placement between first and second vertebral bodies. The implant includes: first and second bone engaging members each having a surface configured to respectively engage opposed first and second vertebral bodies; first and second pistons disposed on one the bone engaging member and cooperating with mating cylinders disposed on the opposite bone engaging member, the pistons moveable between a contracted configu-

ration within the cylinders and an extended configuration extending from the cylinders; first and second arcuate, fixed lock members, each having a fixed locking surface, mounted to one of the bone engaging members, each disposed inside one the piston, the fixed lock members extending towards the opposite bone engaging member; first and second moveable lock members, each formed inside one the cylinder for cooperation with the fixed lock members, each moveable lock member having a moveable locking surface configured to engage an opposed fixed locking surface on one the fixed lock member to prevent contraction of the extension means; at least one biasing element acting on at least one the moveable lock member to bias the member into engagement with its associated fixed lock member; and a link member operatively connected between the first and second moveable lock members to coordinate movement therebetween and force the other moveable lock member into engagement with its associated fixed lock.

#### BRIEF DESCRIPTION OF THE DRAWINGS

For the purpose of illustrating the invention, the drawings show aspects of one or more embodiments of the invention. However, it should be understood that the present invention is not limited to the precise arrangements and instrumentalities shown in the drawings, wherein:

FIG. 1 is a perspective view of an intervertebral implant in a contracted configuration embodying features of the invention.

FIG. 2 is a perspective view of the implant shown in FIG. 1 in an expanded configuration.

FIG. 3 is an exploded perspective view of the implant shown in FIG. 1.

FIG. 4A is a top view of the implant shown in FIG. 1.

FIG. 4B is a side cross-sectional view through line 4B-4B of the implant shown in FIG. 4A.

FIG. 5A is a perspective view of a lower part of the implant shown in FIG. 1 with upper portions and bottom face removed.

FIG. 5B is a bottom view of the lower portion shown in FIG. 5A.

FIG. 6A is a perspective view of the upper portion of the implant shown in FIG. 1 with the lower portion removed.

FIG. 6B is an enlarged perspective view of the staircase-like lower lock support shown in FIG. 3.

FIG. 7 is a partial side view of one of the locking mechanisms of the implant shown in FIG. 2.

FIGS. 8A-9B are partial side views of the locking mechanism in FIG. 7 shown in different expanded and locked configurations.

FIGS. 10A and 10B of the locking mechanism illustrate the expanded but unlocked configuration in FIG. 10A and the expanded and locked configuration in FIG. 10B.

FIGS. 11A and 11B are perspective views of the lower lock support and spring locking actuator illustrating the operation thereof.

FIG. 11C is a perspective view of an alternative locking mechanism and locking actuator embodying features of the invention.

FIGS. 12A-12C are perspective views of alternative lower lock support designs embodying features of the invention.

FIGS. 13A-13B are perspective and side views respectively of an alternative implant embodying features of the invention which has an articulating top end plate.

FIG. 14A is an exploded perspective view of yet another alternative implant embodying features of the invention which has the lower lock supports within the extendable pistons.

FIG. 14B is a top view of the implant shown in FIG. 14A.

FIG. 14C is a side cross-sectional view through line 14C-14C of the implant shown in FIG. 14B.

FIG. 15 is a perspective view of an alternative implant design having features of the invention wherein the locking mechanism surrounds a central opening in the top end plate.

FIG. 16 is a perspective view of an alternative implant design having features of the invention wherein the expanding piston is centrally located and locking mechanisms are provided on both sides of the expanding piston.

FIG. 17 is a simplified schematic illustration of an alternative implant design having ratchet and pawl locking members between the top and bottom plates of the implant.

FIG. 18 is a perspective view of an alternative implant design with ratchet and pawl locking members between the top and bottom plates of the implant.

FIG. 19 is a cross-sectional perspective view of an implant design with ratchet and cantilevered spring members between the top and bottom plates of the implant.

FIGS. 20-29 schematically illustrate various means for locking an expanding member of implants in extended configurations embodying features of the invention.

FIG. 30 is a perspective view of yet another alternative implant design having features of the invention wherein the locking mechanism has straight upper and lower interfitting lock supports.

FIGS. 31A-31G illustrate an alternative implant locking mechanism in which a wire-form surrounds a pair of upper support members with grooves configured to receive the wire-form.

FIGS. 32A and 32B are perspective views of a further alternative embodiment of the present invention including locking, conical bone engaging anchors.

FIGS. 33A-C are perspective views showing alternative bone engaging anchors.

FIGS. 34A and 34B are perspective cross-sectional views of another alternative embodiment of the present invention including locking, screw-threaded bone engaging anchors.

FIGS. 35A and 35B are perspective views of yet another embodiment of the present invention including locking, telescoping bone engaging surfaces.

FIGS. 36A and 36B are cross-sectional views of another exemplary embodiment of the present invention shown in a collapsed and an expanded configuration respectively.

FIG. 36C is a posterior perspective view of the embodiment in FIG. 36B, shown in an expanded state.

FIGS. 37A and 37B are end views of a lift mechanism according to a further exemplary embodiment of the present invention, shown in a collapsed and an expanded configuration respectively.

FIGS. 38A and 38B are end views of a cross section of another embodiment of the present invention utilizing the lift mechanism shown in FIGS. 37A and 37B, shown in a collapsed and an expanded configuration, respectively.

FIGS. 39A and 39B are top views of the respective embodiments shown in FIGS. 38A and 38B with the top plate removed.

FIG. 40 is an anterior perspective view of the embodiment shown in FIG. 38B.

FIG. 41 is a posterior perspective view of still another exemplary embodiment of the present invention, shown in an expanded configuration.

FIG. 42 is a perspective view of a lift mechanism of the embodiment of FIG. 41.

FIGS. 43A and 43B are cross-sectional views of the embodiment of FIG. 41 shown in a collapsed and an expanded configuration, respectively.

FIG. 44 is an exploded perspective view of another embodiment of the current invention.

FIG. 45A is a partial inferior perspective of another embodiment of the present invention.

FIG. 45B is a partial top view of the embodiment shown in FIG. 45A.

FIG. 46A is an exploded perspective view of another embodiment of the current invention.

FIGS. 46B and 46C are superior perspective views of the embodiment shown in FIG. 46A in the collapsed and expanded configurations respectively.

FIG. 47 is an exploded perspective view of another embodiment of the current invention.

FIG. 48 is an exploded perspective view of another embodiment of the current invention.

FIG. 49 is an exploded perspective view of another embodiment of the current invention.

#### DETAILED DESCRIPTION

FIGS. 1-10B illustrate an example of an intervertebral implant 10, a Selectively Expandable Cage (SEC), having features of the invention. The implant 10 generally includes a housing 11, a housing base 12, an interlocking top end plate 13, a bottom end plate 14, an interior cavity 15 within the housing 11 and a pair of cylinders 16. The top and bottom end plates are the bone engaging members of the implant, providing surfaces for engaging vertebrae above and below the implant when placed in the patient. Upper lock supports 17 are attached to the underside of the top end plate 13 thus forming fixed lock members and have multi-stepped lower support surfaces 18 much like an inverted staircase. Lower lock supports 20, having multi-stepped upper support surfaces 21 surround cylinders 16 much like an upright staircase. The multi-stepped support surfaces form the locking surfaces of the lock supports. Pistons 22 are secured to the under surface of top end plate 13. Seal members 23 are slidably disposed within the cylinders 16 and are mounted on pistons 22. The upper surface 24 of bottom end plate 14 is provided with locking actuator channels 25 which partially receive spring locking actuators 26. The base 12 of the housing 11 has arcuate slots 27 which are configured to slidably receive the depending elements 28 or locking actuator transfer element of the lower lock supports 20 and partially receive the spring locking actuators 26. Depending elements 28 engage the forward end 30 of spring locking actuators 26. The spring locking actuators 26 are initially in a compressed configuration so that upon the extension of the top end plate 13 and the attached upper lock supports 17, the lower lock supports 20 rotate about the cylinders 16 due to the force applied by the biased spring locking actuator 26 thus forming moveable lock members. This causes the lock support surfaces 21 of the lower lock supports 20 to engage support surfaces 18 of the upper lock supports so as to lock the top end plate 13 in an extended configuration. The support surfaces 18 of the upper lock supports 17 and the support surfaces 21 of the lower lock supports 20 are tiered with multiple steps so that the implant 10 can be locked at several different expanded heights. The underside stepped support surfaces 18 of the upper lock support 17 may be provided with increasing riser height (alignment faces 46) in the upward direction to provide smaller incremental expansion near the end of the piston expansion.

In addition or alternatively, the stepped support surfaces 21 of the lower lock support 20 may be provided with decreasing riser height in the upward direction for the same reason. A variety of riser heights of the upper lock support 17 or lower lock support 20 can be provided. The lowermost stepped support surface 18 of the upper lock support 17 and the uppermost stepped support surface 21 of the lower lock support 20 may be provided with various lengths and widths to ensure better support.

As can be seen in FIG. 2 there are two sets of upper lock supports 17 attached to the top end plate 13 and there are two sets of lower lock supports 20 in this embodiment, but a single set or more than two sets of upper and lower lock supports can also be used to lock the implant 10 in the expanded state. Also shown, for example, in FIG. 2 are cylinders 16 and pistons 22, which provide one example of extension means in embodiments of the present invention. Other examples of extension means are described herein below in connection with alternative embodiments of the invention.

The implant 10 is configured to be implanted between opposing vertebral bodies in the spine to facilitate bony fusion between those vertebral bodies. The implant 10 is shown in its collapsed or contracted configuration in FIG. 1 and in one example of its expanded configuration in FIG. 2. In the collapsed state, the implant 10 can be inserted easily into the intervertebral body space through a minimal incision and with minimal tissue removal. Once in that space, the implant 10 can be expanded against the two opposing vertebral bodies to distract them and thereby restore height to the intervertebral space. This provides stable opposition of the implant 10 to both vertebral bodies and optimizes the bony fusion process. The fusion process can also be enhanced by filling the interior cavity 15 with autologous bone graft, a bone growth enabling matrix, and/or bone growth stimulating substances prior to and/or after insertion into the body.

Further details of individual parts of the implant 10 are depicted in FIGS. 3, 4A and 4B. Pistons 22 are attached to the underside of the top end plate 13 which are configured to support seal members 23 which run inside of cylinders 16 located in the housing 11. When the cylinders 16 are pressurized as will be described in more detail below, the seals 23 running inside the cylinders 16 and pistons 22 slidably disposed within the seals are vertically displaced, translating the top end plate 13 vertically above the housing 11. Lower lock supports 20 are located around the outer wall of the cylinders 16. When the top end plate 13 is vertically displaced, which in turn displaces the attached upper lock supports 17, the lower lock supports are rotated by the biased locking actuators 26 to a locking position. Arcuate locking actuator channels 25 in the top surface of bottom plate 14 and the arcuate slots 27 in the housing base 12 confines the locking actuators 26 to the housing 11.

Additional details of the housing 11 are depicted in FIGS. 5A and 5B. The housing 11 comprises an outer wall 31 and cylinders 16 which are secured to housing base 12. The outer wall 31 supports a leading nose 32 on the distal end and a delivery boss 33 on the proximal end. The leading nose 32 has inwardly directed side tapered faces 34 and top tapered face 35 and bottom tapered face 36. These tapered faces 34, 35 and 36 enable non-traumatic insertion of the implant 10 past neural elements and between the vertebral bodies. The delivery boss 33 contains a delivery tool anchor 37 which allows secure attachment of the implant 10 to a delivery tool (not shown), which is illustrated in co-pending application Ser. No. 11/535,432, filed Sep. 26, 2006, and Ser. No. 11/692,800, filed Mar. 28, 2007 for insertion into a vertebral space. The delivery boss 33 also contains pressure input ports 38 which

are used to deliver a pressurized fluid to the interiors of cylinders 16. The outer wall 31 of the housing 11 also provides side openings 40 which provide space for bony in-growth into central cavity 15 in the housing 11 and provide radiolucent openings for the radiographic imaging of the process of bony in-growth. The housing base 12 also contains pressure channels 41 which deliver pressurized fluid from the pressure input ports 38 to the interior of cylinders 16. Although the housing base 12 of implant 10 is depicted with independent pressure channel 41 for each cylinder 16, other embodiments can contain one or more branching pressure channels for delivering pressurized fluid to two or more cylinders 16. As previously mentioned, the housing base 12 also has locking actuator slots 27 which hold and guide the locking actuators 26. The locking actuator slots 27 contain a wider portion, locking actuator opening 42, to enable insertion of the locking actuator 26 into the channels defined by the locking actuator slots 27 in housing base 12 and the locking actuator channels 25 in the bottom end plate 14. The housing base 12 also has optional alignment bosses 19 which align the bottom end plate 14 to the housing 11 via optional alignment holes 9.

FIGS. 6A and 6B illustrate further details of the top end plate 13 and the lower lock support 20. The two sets of pistons 22 and upper lock supports 17 are joined by connecting members or struts 44. The pistons 22 have seal bosses 45 on which the seals 23 are mounted. The upper lock supports 17 have tiered lower support surfaces 18 and risers or alignment faces 46. The tiered or stepped support surfaces 18 of the upper lock supports 17 engage the stepped or tiered support surfaces 21 of the lower lock supports 20. The alignment faces 46 of the upper lock support are configured to engage the alignment faces 47 of the lower lock supports 20. The uppermost support surface of the lower lock support 20 has a lock support stop 50 which engages with the lower most alignment faces 46 of the upper lock support to prevent the lower lock support 20 from over rotating as it engages the upper lock support 17. The bottom of the lower lock support 20 also has the locking actuator transfer element 28 which engages the forward end 30 of the spring locking actuator 26 to transfer the actuation force from the locking actuator 26 to the lower lock support 20.

FIGS. 7 through 10B show details of the selectively expanding locking sequence of implant 10 with the housing 11 removed. The collapsed configuration is shown in FIG. 7 with the support surfaces 18 of the upper lock support 17 resting on the support surfaces 21 of the lower lock support 20. The locking actuator 26 is a biasing element, such as a spring, that engages the depending element or locking actuator transfer element 28 to urge the alignment faces of the lock supports in a direction where they contact. Thus, in one exemplary embodiment, the alignment faces 47 of the lower lock supports 20 are forced against the alignment faces 46 of the upper lock support 17. The lock support stops 50 fit within the lower lock stop relief 52 (shown best in FIG. 6A) on the top end plate 13. When the cylinders 16 are pressurized, the pistons 22 raise the top end plate 13 and attached upper lock supports 17 (straight arrow) moving the support surfaces 18 of the upper lock support 17 off of the support surfaces 21 and moving the lower alignment faces 46 past the upper alignment faces 47. When the alignment faces 46 of the upper lock support 17 have cleared the alignment faces 47 of the lower lock support 20, the locking actuators 26 (in this embodiment a compressed coiled spring) engaging the locking actuator transfer element 28 force the lower lock supports 20 to rotate (curved arrow in FIGS. 8B and 9B). The support surfaces 21 of the rotating lower lock supports 20 move to the next lower

level of the support surfaces 18 of the raised upper lock supports 17 until the alignment faces 47 of the lower lock supports 20 engage the next level of the alignment faces 46 of the upper lock supports 17. The lower lock support 20 and upper lock support 17 then lock the top end plate 13 at this expanded level. This process repeats itself at each locking level (FIGS. 8A, 8B, 9A, 9B and 10A) until the top level (or somewhere between) is reached as shown in FIG. 10B. At this top level, the locking actuators 26 engage the locking actuator transfer elements 28 and the lower lock supports 20 are rotated so the lowermost alignment surface 46 of the upper lock support 17 engages lock support stop 50 of the uppermost support surface 21 of the lower lock support 20. At this highest locked level only the lowest support surfaces 18 of the upper lock supports 17 and the highest support surfaces 21 are engaged providing all of the locking support. As can be seen from FIGS. 10A and 10B the lowest support surfaces 18 of the upper lock supports 17 and the highest support surfaces 21 of the lower lock supports 20 can be wider than the other support faces to provide sufficient support material when only these two faces are engaged.

FIGS. 11A and 11B illustrate the operation of locking actuator 26. In this embodiment the spring locking actuator 26 is compressed into an arc beneath the lower lock support 20. One end of the spring locking actuator 26 is constrained by the housing 11 (not shown) and the other is engaged with the locking actuator transfer element 28. When the lower alignment faces 46 of the upper lock support 17 are raised above the upper alignment faces 47 of the lower lock support 20 by the extension of piston 22, the locking actuator 26 pushes against the locking actuator transfer element 28 and rotates the lower lock support 20 in a clockwise direction (arrow) as viewed from above. It should be noted that in the embodiment of the current implant as described thus far, the angular orientation of the tiered upper and lower support surfaces 18 and 21 can vary when there is more than one set of supports. As shown in FIG. 3 the proximal lower support surfaces 21 are oriented clockwise as viewed from above and the distal lower support surfaces 21 are oriented counterclockwise. This opposite orientation provides enhanced locking support for rotational forces applied to the implant.

An alternative locking actuator 26a is shown in FIG. 11C as a torsion spring. This locking actuator 26a has constraining tab 53 secured to the lower lock support 20 and constraining tab 54 secured to the housing 11. Just as the compression spring shown in FIGS. 11A and 11B applies a force to the lower lock support 20 to rotate it, the torsion spring in FIG. 11C does the same. An extension spring would work equally as well as a locking actuator 26a. Spring actuators can be made of an appropriate biocompatible material such as stainless steel, NITINOL, titanium or a suitable polymer. Locking actuators are not limited to springs. A wide variety of mechanisms can be used to actuate the lower lock supports 20, including but not limited to, a linear drive, an externally actuated tensile member, a worm gear, an inflated member such as a balloon or bellows, a magnet, a rotational drive such as a micro motor, a super elastic shape memory element, and the like.

FIGS. 12A through 12C show variations of the lower lock support 20 described above. In FIG. 12A a tri-set lock support 20a is shown whereby there are three sets of upper support surfaces 21a, upper alignment surfaces 47a and lock support stops 50a rather than the two sets described above. This tri-set lower lock support 20a has two advantages over the two sets design, 1) there are three support columns rather than two locking the implant 10 in an expanded state thereby creating a more stable lock and 2) the tri-set lower lock support 20a has

11

to move or rotate much less for each locking level. This last advantage is significant when the locking actuator is a spring such as spring locking actuator **26** as this places less strain on the spring to achieve the required locking force at each step. Each lower lock support column will have a corresponding upper lock support column (not shown). The upper support surfaces **21** and lower support surfaces **18** are not limited to two or three sets of surfaces. Any number of sets of support surfaces including a single set may be employed.

FIG. **12B** shows an inter-digitating lower lock support **20b**. Each of the inter-digitating upper support surfaces **21b** on the inter-digitating lock support **20b** is paired with an inter-digitating stop **50b** which when paired with matching inter-digitating support surfaces and stops of an upper lock support (not shown) prevents the inter-digitating support surfaces **21b** from moving relative to the inter-digitating support surfaces of an upper lock support to unlock the implant without the inter-digitating lower support faces first lifting above the inter-digitating stop **50b**. This design provides an enhanced locking feature. Upper alignment surfaces **47b** are again provided.

Generally the lower support surfaces **18** and the upper support surfaces **21** are horizontal to maximize vertical support in the locked implant. However, the locking support **20c** shown in FIG. **12C** provides an enhanced locking feature by providing inclined support surfaces **21c** which have a slope relative to the horizontal which requires matching inclined lower support surfaces on the upper lock supports (not shown) to be lifted above the inclined upper support surfaces **21c** before the upper lock support can be rotated to unlock the implant.

FIGS. **12A** and **12C** show various lengths of locking actuator transfer elements or depending elements **28**. The locking actuator transfer element **28** can vary in length depending on how much engagement is desired between the locking actuator transfer element **28** and the locking actuator slots **27**. The locking actuator transfer element **28** includes one or more transfer element tabs **29a** and **29c** which vertically constrain the lower lock support **20** to the locking actuator slots **27** in the housing **11**. The wider locking actuator opening **42** described above (see FIG. **5B**) enables insertion of the locking actuator transfer element **28** with transfer element tabs **29a** and **29c** into the locking actuator slots **27** in housing base **12** at the rotational position where the locking actuator transfer element **28** is aligned with the locking actuator opening **42**. In other rotational positions the transfer element tabs are constrained by lateral extensions on the sides of the narrower locking actuator slots **27**. In this manner the locking actuator transfer element **28** provides both the function of transferring force from the locking actuator **26** to the lower lock support **20** as well as constraining the lower lock support **20** to the housing **11**. This latter function prevents the frictional forces between the lower alignment faces **46** and the upper alignment faces **47** created by the biased spring locking actuator **26** from lifting the lower lock support **20** along with the upper lock support **17** when the upper lock support **17** is lifted by the piston **22**.

As an alternative to the locking actuator transfer element **28**, the embodiment shown in FIG. **12B** depicts a locking actuator guide channel **80**. This locking actuator guide channel **80** engages a tensile member (not shown) which transfers actuation force from the locking actuator **26** to the lower lock support **20**. Tensile members can be any of a number of known elements such as sutures made of polymers or natural materials, metal cable, plastic or metal rod and the like.

FIGS. **13A** and **13B** illustrate an alternative design of an implant **110** embodying features of the invention. The

12

implant **110** has independent actuation of the distal piston **122a** and proximal piston **122b**. The two pistons **122a** and **122b** are interconnected by an articulating top end plate **113** which allows independent lift and locking of each side of the implant **110**. This independent lift and locking of both ends of the implant **110** enables the implant to conform to intervertebral end plates that have uneven lateral heights between them. Further, this independent lift and locking allows the implant **110** to be used to create varying lateral heights between vertebral end plates which can be useful to compensate for a scoliosis in the spine.

Implant **110** has a housing **111** which has an alternative delivery tool anchor **160** located in it as well as alternative pressure input ports **137**. A variety of anchor designs or pressure ports can be used with any of the embodiments of the current device without departing from the scope of this invention. Lock and unlock access ports **138** are also located on this housing **111**. These ports are used to guide lock and unlock mechanisms (not shown) which can be manipulated externally to the implant **110** to actuate the lower lock support **120** to not only move it under the upper lock support **117** to hold the piston **122b** and articulating end plate **113** in an expanded position, but also to move the lower lock support **120** away from the upper lock support **117** to allow the piston **122b** and articulating end plate **113** to collapse back into the housing **111**. This latter action may be desirable to remove the implant **110** from or reposition the implant within the intervertebral space. A variety of lock/unlock mechanisms can be used with the current invention such as but not limited by, a tensile member including suture thread and metallic cable, a compressive member such as a metallic or polymer rod, pressurized fluid, a rotating drive, a super elastic shape memory element, and the like.

FIGS. **14A-14C** depict yet another alternative implant **210** that embodies features of the invention. Implant **210** has an interfacing top plate **213** which connects to separate and freely rotating pistons **222** via the piston capture plate **270** on the interfacing top plate **213** and the piston heads **271** on the rotating pistons **222ab**. The rotating pistons **222ab** also interiorly contain upper lock supports **217** with support faces **218** and alignment faces **246**. Seals **223** are mounted on the rotating pistons **222ab** and the seals **223** and rotating pistons **222ab** fit into internal cylinders **216** that are located on the housing **211**. The internal cylinders **216** have lower lock supports **220** with support surfaces **221** and alignment faces **247** as well as lower retaining features **273**. The housing **211** also contains one or more pressure input ports **238**.

In use, the implant **210** is inserted into the intervertebral body space in a collapsed state and fluid pressure is delivered through the pressure input port(s) **238** to the internal cylinder(s) **216** to raise the seal(s) **223** and rotating piston(s) **222ab** out of the internal cylinder(s) thereby raising the interfacing top plate **213** and expanding the implant **210**. Once the rotating pistons **222ab** have been raised such that the lower alignment faces **246** of the upper lock supports **217** have cleared the upper alignment surfaces **247** of lower lock supports **220**, an actuator (not shown) rotates the rotating pistons **222ab** such that the lower support surfaces **218** of the upper lock supports **217** are moved above the upper support surfaces **221** of the lower lock supports **220**, to thereby lock the implant **210** in the expanded configuration. The actuator can be one or more tensile members such as suture threads or cables that extend from the user into the implant **210** through the lock and unlock access ports **238** on the interfacing top plate **213** to the piston head **271**. Applying tension to one or more tensile members when the piston is in an extended configuration will rotate the piston heads **271** such that the

13

support surfaces **218** of upper lock supports **217** are moved above the support surfaces **221** of the lower lock supports **220** thereby locking the implant **210**. Alternatively or in addition to applying tension to lock the implant **210** in an expanded configuration, applying tension to one or more tensile members will rotate the piston heads **271** such that the lower support surfaces **218** are moved away from the upper support surfaces **221** thereby unlocking the implant **210** and allowing the rotating pistons **222ab** to seat back into the internal cylinders **216** such that the implant **210** is once again in a collapsed configuration.

FIG. **15** illustrates an alternative implant design **310** embodying features of the invention which has a housing **311**, top end plate **313** and pistons **322** similar to the prior embodiments. This implant **310** has upper lock supports **317** and lower lock supports **320** within a central portion of the implant. The upper lock supports **317** are secured to the top end plate **313** and the lower lock supports **320** are secured to the base **314** with depending elements (not shown) as was described above and are moved as in the prior embodiments.

FIG. **16** illustrates an alternative implant design **410** embodying features of the invention which has a housing **411**, top end plate **413** and a centrally located piston **422** similar to the prior embodiments. This implant **410** has upper lock supports **417** and lower lock supports **420** distal and proximal to the centrally located cylinder **416** and piston **422**. The upper lock supports **417** are secured to the top end plate **413** and the lower lock supports **420** are secured to the base **412** and are moved as in the prior embodiments via depending elements (not shown) as was described above.

FIG. **17** shows another alternative implant **510** which has a pair of pistons **522** and which has a locking support system which includes ratchets **521** on the base **512** and pawls **517** pivotally mounted to and depending from the top end plate **513**. Expansion of the pistons **522** causes the free ends **518** of pawls **517** to engage recesses **520** in the ratchets **521** so as to lock the top end plate **513** in an extended configuration.

FIG. **18** illustrates another alternative implant design **610** which is similar to that shown in FIG. **17**. In this embodiment the free end of the pawl **617** has a plurality of teeth **618** to provide greater effective contact between the pawl **617** and the ratchet **621** for locking of the implant **610**.

FIG. **19** is a cross section embodiment, showing implant **710** embodying features of the invention. In this embodiment the pistons **722** are surrounded by upper lock support **717** which has at least one cantilever extension ending at the support surface **718**. The support surfaces **718** are captured by the recessed support surfaces **721** which are located on the inner wall of the housing **711**. Once the pistons **722** are expanded in an upward direction, the support surfaces **718** of the upper lock support **717** engages the recessed support surfaces **721** locking the implant **710** in place. The upper lock support **717** can be rotated relative to the piston **722** and housing **711** to disengage the support surfaces **718** from the support surfaces **721** to unlock the implant **710** and lower the pistons **722** as needed. Alternatively the implant **710** can be unlocked by rotating the upper lock support constraints **775** relative to the upper lock support **717** to press on the cantilever extensions and disengage the support surfaces **718** from the support surfaces **721**.

FIGS. **20A-31** illustrate a variety of suitable means for locking extendable members such as pistons in extended configurations. FIGS. **20A**, **20B**, **21A**, **21B**, and **22-31** show variations of lower lock supports and upper lock supports. In each of these variations there are support surfaces on the lower lock supports which engage support surfaces on the upper lock supports.

14

In FIGS. **20A** and **20B** support surfaces **818** comprise grooves set into the upper lock support **817**. The lower lock support **820** is a U-shaped tong which is configured to advance (as indicated by the arrow in FIG. **20A**) towards the upper lock support **817** and to engage one of the grooves with its upper support surface **821** for locking an implant not shown in these drawings. Lower lock support **820** is withdrawn (as indicated by the arrow in FIG. **20B**) from the groove to disengage the lower lock support and unlock the implant.

In the variation shown in FIG. **21A**, the lower lock support **920** is a plate with an upper lock clearance opening **970** that is shaped to allow passage of the cylindrical flat-sided upper lock support **917** through the lower lock support **920** (arrow). As shown in FIG. **21B**, once the lower lock support **920** is positioned at the desired location it can be rotated approximately  $90^\circ$  (arrow) to engage the support surfaces of the lower lock support **920** with the support surfaces **918** of the upper lock support **917**. The shape of the upper lock support **917** and mating upper lock clearance opening **970** on the lower lock support **920** are not restricted to the profile shown in FIGS. **21A** and **21B** nor is the locking actuation restricted to  $90^\circ$  rotation of one of the elements but can vary to any number of shapes that allow passage in one configuration but constraint when one of the elements is moved to another configuration.

In FIG. **22**, the upper lock support **1017** is a cylinder with notches cut to create support surfaces **1018**. The lower lock support **1020** is a pivoting pin **1070** with a pawl **1071** for the lower support surface **1021**. In the configuration shown, the support surface is biased as indicated by the arrow **1072** to allow the upper lock support **1017** to rise with an expandable member of an implant and to prevent the upper lock support from dropping. This allows the device to lock at each level when the subsequent support surface **1018** of the upper lock support **1017** engages the support surface **1021** of the lower lock support **1020**. In this variation having features of the present invention, the upper lock support **1017** can also be lowered by moving the pivoting pin **1070** of the lower lock support **1020** away from the upper lock support **1017** to disengage the support surface **1021** from the support surface **1018**.

FIG. **23** shows yet another embodiment having features of the invention where the lower lock support **1120** is a pin configured to engage (arrow) support surfaces **1118** located in the upper lock support **1117**. The lower lock support **1120** does not have to engage the full thickness of the upper lock support **1117** as shown in this figure, nor does the support surface **1118** have to extend through the entire thickness of the upper lock support **1117** but rather can engage any portion of the upper lock support **1117** that is sufficient to lock an implant in position. This embodiment also allows a variety of shapes of pins **1120** and matching support surfaces **1118**.

In FIG. **24** the lower lock support **1220** is a grip with two pivoting jaws **1270**, the ends of which have support surfaces **1221**. The upper lock support **1217** has a series of notches which have the support surfaces **1218**. A lock actuator such as a compressive spring (not shown) can apply force (as shown by the arrows **1272**) to the grip base extensions **1273** to lock the device. This variation having features of the invention allows the upper lock support **1217** to move upwards but prevents downward motion thereof. Downward motion of the upper lock support **1217** can be allowed by reversing the force on grip base extensions **1273**.

Not all locking systems embodying features of the invention require the engagement of support surfaces of the upper lock supports directly on top of the support surfaces of the

15

lower lock supports. A frictional support can be created to lock the device as shown in FIGS. 25 through 32.

In FIG. 25 the upper lock support 1317 has one or more flat surfaces as the support surfaces 1318. The lower lock support 1320 has one or more pivoting pawls that have a support surface 1321 that engage the support surface 1318 and supports a load (arrow).

In FIG. 26 the upper lock support 1417 has an exterior support face 1418 which is gripped by the support face 1421 on the inner diameter of the wrapped lower lock support 1420. This lower lock support 1420 can be a torsion spring that in its free state grips the upper lock support 1417 and releases the upper lock support when a force (arrows) is applied to one or more of its ends 1470 as shown to increase the spring's inner diameter. The reverse is possible where in its free state the lower lock support 1420 allows movement of the upper lock support 1417 inside the inner diameter. When a tensile force is applied to the ends 1470 to reduce the inner diameter, the lower lock support grips the support surface 1418 of the upper lock support 1417 to lock the implant.

FIGS. 27A and 27B show another variation which can be described as a canted washer type device. The lower lock support 1520 is a plate with an upper lock clearance opening 1570 which allows relative movement of the upper lock support 1517 as shown in FIG. 27A. When the lower lock support 1520 is canted as shown in FIG. 28B, the edge of the upper lock clearance opening 1570 comprises a lower support surface 1521 which engages the upper support surface 1518 which is the outer surface of the upper lock support 1517 locking it relative to the lower lock support 1520.

Yet another variation of the gripping lock of the current invention is shown in FIG. 28. In this variation the lower lock support 1620 comprises one or more jaws which have support surfaces 1621 that are configured to be forced against the support surface 1618 of the upper lock support 1617 to produce friction to lock the device in place.

FIG. 29 illustrates a lower lock support 1720 which comprises a pivot and pawl as has been detailed above. The end of the pawl comprises a lower support surface 1721 which engages an upper support surface 1718 on the upper lock support 1717. In this embodiment the upper lock support 1717 is rotated counter clockwise by an expanding element (not shown). This rotation in turn raises the piston 1722 which expands the implant. In this manner the upper lock support 1717 is integrated into the lifting mechanism to engage the lower lock support 1720 and lock the implant as it expands.

FIG. 30 illustrates yet another alternative implant 1810, similar to that shown in FIG. 1 except that the upper locking member 1817 and lower locking member 1818 have a linear shape rather than the arcuate shape of the prior embodiments. The implant 1810 generally has a housing 1811, a top plate 1813, a bottom plate 1814, pistons 1822 and cylinders 1816. The upper locking member 1817 has support surfaces 1818 and the lower locking member 1820 has support surfaces 1821. The implant 1810 has a locking actuator (not shown).

FIGS. 31A-31G illustrate another implant 1910 embodying features of the invention which have upper locking members 1917 with grooves 1970 having support surfaces 1918 and lower locking member 1920 with locking surfaces 1921. The lower locking member 1920 is a wire-form which encircles the exterior of both upper locking members 1917 and is configured to seat within the grooves 1970. Expansion of the lower locking member 1920 (arrows in FIG. 31B) by the locking actuator (not shown) causes the lower locking member 1920 to be pulled out of the groove 1970 and allows the upper locking member 1917 to rise with the expansion of the implant. Release of this expansion of the lower locking

16

member 1920 (arrows in FIG. 31A) allows the lower locking member 1920 to seat back into the groove 1970 locking the implant 1910.

FIG. 31G illustrates a detail of an alternative implant 1910a embodying features of the invention which have upper locking members 1917a with grooves 1970a having support surfaces 1918a and lower locking member 1920a with locking surfaces 1921a. The lower locking member 1920a is a wire-form which encircles the exterior of both upper locking members 1917a and is configured to seat within the grooves 1970a. The support surface 1918a locks on the support surface 1921a when there is a compressive or downward force (hollow arrow) on the upper locking member 1917a locking the implant 1910a. Upward force or extension (solid arrow) of the upper locking member 1917a causes the lower locking member 1920a to ride on the disengaging surface 1919a and out of the groove 1970a allowing the upper locking member 1917a to rise with the expansion of the implant 1910a.

In a further aspect of the present invention, a piston/cylinder and locking arrangement as described above may be used to deploy extendable bone anchors. For example, implant 10A with conical bone engaging anchors 60 as shown in FIGS. 32A and 32B may be constructed with pistons 22 and cylinders 16 as described above in connection with implant 10 and shown, for example, in FIGS. 2, 3 and 4B. Implant 10A has a housing 11 as previously described and may include other previously described features such as interior cavity 15 for bone growth stimulating substances. However, in this embodiment, instead of upper interlocking end plate 13, the two pistons 22 individually terminate with conical bone engaging anchors 60. The bone engaging anchors, including sharp leading tip 62, form surface for engaging the vertebral body.

As shown in FIG. 32A, bone engaging anchors 60 are in a contracted configuration, within housing 11, to facilitate insertion of implant 10A. Using hydraulic actuation as previously described, bone engaging anchors 60 are moved to an extended configuration as shown in FIG. 32B, wherein at least leading tip 62 extends beyond housing 11 to engage and anchor in the bone. In order to ensure that the bone engaging anchors remain firmly engaged in the bone, locking mechanisms including multi-stepped upper and lower lock supports 17, 20 as previously described in connection with implant 10 and shown, e.g. in FIGS. 6A-12C, are provided to support each anchor 60 in the extended configuration. With this arrangement, the extended and locked anchor 60 helps to retain the implant in place.

A variety of alternatives are possible for the bone engaging anchor according to the invention as illustrated in FIGS. 33A-C. For example, implant 10B in FIG. 33A includes bone engaging anchors formed as spike 60A and blade 60B. Blade 60B can be particularly effective in preventing motion along the insertion path after deployment. In this case, the length of the blade 60B is aligned in the direction shown by arrow A. This is substantially orthogonal to the direction of implantation (arrow B) and would resist movement in that direction. Implant 10F, shown in FIG. 33B includes further possible variations. In this embodiment, the bone engaging anchors are formed as barbed spikes 60C. Barbs 61 along the shaft of the spikes resist forces that tend to move the tissue away from the implant along the axis of the anchor (much as the screw threaded anchor described below would also resist this force). Also included in implant 10F is a lateral bone engaging anchor 63 for anchoring in laterally oriented tissue. In the illustrated embodiment, lateral anchor 63 includes a plain spike 60A. Lateral anchor 63 is formed in the same manner and with the same components, i.e. piston, cylinder, locking



17

mechanism, etc. as elsewhere described in this application, except that the components are oriented laterally as shown. To provide support for the bone anchor components in this lateral embodiment, housing 11 includes a central member 11A that divides interior cavity 15 into two portions. In the configurations of implants 10B and 10F, the top of piston 22 can also become a bone engaging surface when the anchor member is fully received within the bone. FIG. 33C shows a further alternative implant 10G, including anchors 65 extending obliquely from housing 11, rather than orthogonally. This oblique arrangement is helpful in resisting side to side rotational forces (for example when the patient/spine bends towards the side) and expansion forces. Once again, obliquely extending anchors 65 are essentially identical to other bone engaging anchors described herein except for the oblique orientation. Here, holes 68 are provided in top end plate 66 for the spikes to pass through. In general, bone engaging anchors according to embodiments of the invention should have a relatively small termination (e.g. tip 62) relative to the size of the piston diameter so that the force on the piston created by the hydraulic fluid is proportionally a much greater force at the small anchor termination to enhance its ability to extend into hard bony tissues. It will also be appreciated by persons skilled in the art that the various features of the bone engaging elements, e.g. spike, blade, barbs, etc., described herein may be combined in any desired combination, in addition to the exemplary combinations shown in the figures of the present application.

In another alternative embodiment, illustrated in FIGS. 34A and 34B, implant 10C includes screw-threaded members 64 as bone engaging anchors. Implant 10C also illustrates a further alternative wherein the bone engaging surfaces, such as the anchors, extend from opposite sides of the implant. In this exemplary embodiment, interlocking end plate 13 is replaced with an integrated top end plate 66. Holes 68 are provided for threaded member 64 to pass through. Persons of ordinary skill in the art will appreciate that holes 68 will be located as needed; in the illustrated embodiment one is in top end plate 66 and the other in bottom end plate 14.

Threaded members 64, as bone engaging anchors extend outwardly from pistons 22. In order to rotate the threaded anchors into the bone when the pistons are extended, the inner wall of housing 11 is provided with a screw-threaded surface 70 that mates with corresponding threads 71 cooperating with pistons 22. As previously described, seals 23 act between the pistons 22 and cylinders 16 to prevent leakage of hydraulic fluid. When fluid is pressurized within the cylinders as described for prior embodiments, the piston is extended, but also driven in a circular motion by the engagement between threaded surfaces 70 and 71. The screw-threaded member 64 is thus driven into adjacent bone as it is extended to anchor the implant.

Once again, locking mechanisms as previously described and shown, for example, in FIGS. 6A-12C, may be employed to prevent the bone engaging anchors from becoming unengaged from the bone. In the cross-sectional views of FIGS. 34A and 34B, upper and lower lock supports 17, 20 are visible around the outside of the piston and cylinders. Alternatively, depending on the depth and pitch of the threaded portions, use of a separate locking mechanism may not be required. As persons of ordinary skill will appreciate, the configuration of the threads alone may be sufficient to prevent the anchors from backing out.

FIGS. 35A and 35B illustrate a further aspect of the present invention wherein locking mechanisms as described are utilized to secure telescoping bone engaging surfaces in place. As used herein, telescoping refers to nested, extendable mem-

18

bers including at least one intermediate member between a base and bone engaging member.

Referring first to FIG. 35A, implant 10D has substantially planar bone engaging members 72. Bone engaging members 72 are thus similar to the bone engaging members of implant 10, but instead individually actuated without interlocking end plate 13. The piston/cylinder arrangement is also similar to that previously described except that here upper piston 74 is received in intermediate piston 80. Intermediate piston is in turn received in cylinder 16 as was previously described for piston 22. Upper piston 74 is sealed against intermediate cylinder 78 of intermediate piston by upper piston seals 76 (see FIG. 35B).

The telescoping bone engaging members 72 are secured by locking mechanisms in a similar manner to the earlier described embodiments, with the addition of an upper lock support 82 for the upper piston. Intermediate piston 80 is supported by upper lock support 17 and lower lock support 20 as previously described. Upper lock support 82 includes upper and lower lock supports 84, 86. Thus, upper piston 74 is secured to upper lock support 84 of the upper lock set. Lower lock support 86 of the upper lock set is mounted on top of upper lock support 20 of the lower lock set. One difference from the earlier described embodiments is that separate spring actuators 26 are not required for the upper lock set as they may be rotated along with the lower lock set by actuators 26.

Implant 10E, as shown in FIG. 35B includes a further variation in which the planar portion of upper bone engaging surface 88 is effectively annular with a conical anchor 90 at the center. Advantages of embodiments of the present invention including bone engaging anchors include the ability of the anchors to be extended lateral from the long axis of the implant (i.e., the insertion axis) with a relatively high force using the relatively small connection to the implant of the hydraulic line. This is an advantage over other methods that require larger access or larger connections to the implant for larger tools or non-hydraulic extension forces to extend the anchors into the hard, bony tissue.

Although the previously described embodiments of the invention included cylinders 16 and pistons 22 expanded with a pressurized fluid as the mechanism used to lift the top end plate away from the bottom end plate, embodiments of the present invention are not limited to only such lift mechanisms. In FIGS. 36A-C an alternative embodiment of the present invention comprising implant 10F is shown wherein a pair of bellows 92 replaces the piston and cylinder pairs previously described. One end of bellows 92 is attached to housing 11 and the other end to top end plate 13. A pressurized fluid added via pressure input ports 38 is directed through bellows orifice 94 into the inside of bellows 92 causing the bellows to expand. The expanding bellows forces top end plate 13 away from housing 11 and lower lock supports 20 are rotated to lock the device in the expanded configuration as was previously described. Bellows 92 can be made of any biocompatible material such as the 316 series of stainless steels, titanium or a titanium alloy, a cobalt chromium alloy, or an implantable polymeric material. The bellows can be of an accordion-like folding configuration as shown in FIGS. 36A-C or any other regular or irregular configuration which can fit inside of the housing and lock supports in the collapsed configuration and expand sufficiently when pressurized to lift top end plate 13 the desired amount away from housing 11. Lower lock supports 20 and upper lock supports 17 provide a confining geometry for bellows 92, which allows use of an irregular bellows configuration. With a bellows arrangement as shown in FIGS. 36A and 36B, the amount of lift is not



limited as is the case in a cylinder and piston to the amount that the collapsed cylinder and piston overlap.

Other exemplary embodiments do not rely on the use of a pressurized fluid for expansion. For example, FIGS. 37A and 37B show an alternative rotating cam lift mechanism 93. Cam lift mechanism 93 includes cam 96 with a substantially curved cam surface 95 and a substantially flat top surface 97, rotating shaft 98, and shaft supports 99. Cam 96 is attached to rotating shaft 98, and shaft 98 is supported by and rotates within shaft supports 99. In an implant 10G (FIG. 40) using this mechanism, the shaft supports 99 are anchored to the inside of housing 11 and rotation of shaft 98 (depicted by curved arrows) rotates the curved cam surface 95 against the bottom of top end plate 13 and moves top end plate 13 away from housing 11 as shown in FIGS. 38A-38B, 39A-39B and 40. The shape of cam 96 determines both the amount of lift that is possible and the relative amount of lift to the amount of rotation of the cam. The cam is not limited by 90 degrees of rotation depicted in the figures. Any shape of a cam that is rotated by any amount from as little as 10 degrees to as much as 355 degrees is possible without departing from the scope of the present invention. Shaft rotation can be accomplished by several means as will be discussed in more detail below. Use of cam lift mechanism 93 as the lifting mechanism along with lower and upper locking supports 20 and 17 for implant 10G allows the lift mechanism to support only the initial lifting loads and not have to support the repetitive long-term supporting loads on implant 10G which are borne by the locking supports. Cam 96 does not require a substantially flat top surface 97 as shown in the exemplary embodiment to support top end plate 13, but such a surface provides a rotational endpoint for the surgeon rotating shaft 98.

Another alternative embodiment is implant 10H shown in FIGS. 41, 43A and 43B. Implant 10H uses a rotating screw lift mechanism 193 as shown in FIG. 42. This mechanism includes shaft 98, shaft supports 99, worm gears 170 attached to shaft 98 and a shaft input end 178 at one end of shaft 98. The mechanism also includes lift screws 172, which have lower lift threads 174 and transfer gear 176 and supporting boss 186. Applying a torque via shaft input end 178 turns shaft 98, which turns the attached worm gears 170. Worm gears 170 turn transfer gear 176 on lift screw 172. Lift screw 172 is contained within housing 11 by way of its supporting boss 186, which is seated in housing bearing 188. Rotation of lift screw 172 transfers force from lower lift threads 174 to upper lift threads 182 on upper lift nut 180. Upper lift nut 180 is attached to top end plate 13 so that rotation of shaft input end 178 lifts upper end plate 13 away from housing 11. The relative pitch of worm gears 170 and matching transfer gears 176 and the lower lift threads 174 and matching upper lift threads 182 can be varied to achieve the desired amount of lift relative to the amount of rotation and torque. The torque can be applied by any means well known by those skilled in the art including but not limited to electric motor, pneumatic or hydraulic turbine, or manual rotation of an actuator. Shaft input end 178 is shown as a hexagonal post, but any alternative input end can be used without departing from the scope of the present invention, such as, but not limited to, a square or star-shaped post, a square, star or hexagonal-shaped socket, or a keyed shaft.

As shown in FIG. 44, an alternative embodiment of the implant 10I includes a linking element 202 that connects the lower lock supports 20A and 20B. The linking element 202 coordinates the action of the lower lock supports 20A and 20B. When the locking actuator 26 actuates the leading lower lock support 20A, the linking element 202 in turn actuates the following lower lock support 20B. In this embodiment the

implant 10I may require only a single locking actuator 26, however plural locking actuators as described above (see, for example, FIG. 3) may be employed for greater actuation force as needed. In addition to actuating the following lower lock support 20B, the linking element 202 prevents the leading lower lock support 20A from actuating until the alignment faces 46 of both the leading upper lock supports 17A and the following upper lock supports 17B each clear the alignment faces 47 of both the leading lower lock support 20A and the following lock support 20B. In this manner the linking element 202 ensures the coordinated actuation of the lower lock supports 20A and 20B to ensure that the implant 10I will always lock at the same height on both sides. This can be advantageous for certain implants placed in the spine where an even expansion of the implant is desired.

Linking plural lower lock supports, such as supports 20A and 20B, with a linking element 202 for even expansion in the manner described may be advantageous over an implant with a similarly sized single lock support 20, and single cylinder 16 and piston 22 due to the increase in the number of support elements, the broader support base, and the increase in expansion force due to the increased number of cylinder and piston pairs. Increasing the size of a single lock support would still have disadvantages of a larger width that would limit the ability for implantation in minimally invasive surgery. Embodiments of the invention are not limited to just the pair of lower locking supports 20A and 20 B as shown in, for example, FIG. 33. Rather, any number of sets of cylinders 16, pistons 22, upper lock supports 17, and lower lock supports 20, with a locking actuator 26 and the appropriate number of linking elements 202 are possible.

For the embodiment illustrated in FIG. 44, linking element 202 is configured to fit inside attachment grooves 204 on the lower lock support 20A, B. Alternatively, linking element 202 may be configured to rest on the outside diameter of the lower lock support 20A, B. The linking element 202 can also be configured to run underneath the lower lock supports 20A, B as shown in FIGS. 45A-D. For implant 10I in FIG. 44 both of the lower lock supports 20A and 20B rotate in the same direction when actuated. Elements of an alternative implant shown in FIGS. 45A-B include lower lock supports 20 that actuate with rotation in opposite directions. The linking element 202 is guided between the lower lock supports 20 through a link channel 210 in housing 11 (FIG. 45B). The linking element 202 is constrained in the link channel 210 by a channel cover 208. The linking element 202 is connected to the lower lock supports 20 by means of link pins 206.

The linking element can be made from any of a variety of implantable materials including: a titanium wire, a titanium cable, a stainless steel wire or cable, a nitinol wire, a braided or mono-filament suture from any manner of suture material such as silk, polyester, polypropylene, ePTFE, or UHWPE. An implantable material that has a tensile strength sufficient to transfer the actuation force from the leading lower lock support 20A to the following lower lock support 20B as well as flexibility sufficient to follow the link channel 210 and/or rotate around the lock supports 20 may be used. Linking element 202 can be attached to the lower lock supports 20 in a number of ways known to those practiced in the art, the selection of which depends on factors such as the linking element material and the lower lock support material. Suitable techniques include laser welding, resistance welding, adhesive bonding, crimping, attaching with clamps, pins, or screws, or being threaded through an opening and securing with a knot.

Turning now to FIGS. 46A, B and C an implant 10J with an additional feature, an unlocking tether 212 is shown. Unlock-

ing tether **212** is attached to the following lower lock support **20B** in attachment groove **204**. Unlocking tether **212** is attached in the opposite direction as the linking element **202** and can be attached in any of the ways described above for attaching the link element **202**. The proximal end **214** of the unlocking tether **212** exits the housing **11** of the implant **10J** through the unlock port **216**. The proximal end **214** can be actuated by an external force or mechanism (not shown). Actuation of the proximal end **214** of the unlocking tether **212** to translate it away from the implant **10J** causes rotation of the following lower lock support **20B**, which will tension and translate the linking element **202** which will rotate the leading lower lock support **20A**. In this manner the unlocking tether **212** can be used to unlock the implant **10J** so that it can collapse to a lower or to its original height. In FIG. **46B** the implant **10J** is collapsed and the unlocking tether **212** is extended a maximum distance out of the unlock port **216**. FIG. **46C** shows the same implant **10J** with the top plate **13** fully expanded above the housing **11** and locked. The unlocking tether **212** has shortened as it was drawn into the implant **10J** as the lower lock supports **20** rotated into locking position. Tensioning or pulling on the unlocking tether **212** will unlock the lower lock supports **20** and allow the top plate **13** to collapse back into the housing **11**. The ability to unlock and collapse the implant **10J** can be highly advantageous to a physician placing the device if there is a need to reposition or replace the device after it has been expanded in-vivo.

Turning now to FIG. **47**, another embodiment of an implant **10K** is shown with lower lock supports **20** that are located inside the cylinders **16** of the housing **11**. In this embodiment the linking element **202** is a solid bar that can transfer compressive as well as tensile loads. The locking actuator **26** rotates the leading lower lock support **20A**, which pushes on the linking element **202**. The linking element **202** in turn pushes and rotates the following lower lock support **20B**. The lower lock supports **20A** and **20B** engage the upper lock supports **17** that are located inside the pistons **22** (shown in FIG. **14C**). The rotation of the following lower lock support **20B** pulls the unlocking tether **212** into the housing **11** through the unlocking port **38**. The unlocking tether **212** can be tensioned away from the housing **11** to reverse the process and unlock the implant **10K**.

The use of tension and compression elements as described above are not the only means for coordinating the controlled locking and unlocking of the device. In FIG. **48** an alternative embodiment of the implant **10L** is shown wherein thread gears **226A** and **226B** are used to both lock and unlock the lower lock supports **20** thus forming a combined linking and unlocking element. Threaded gears **226A** and **226B** are mounted on a shaft **224** that is contained in the base of the housing. The proximal end of shaft **224** has a keyed head **228** that can protrude from or rest in the locking port **222**. An external tool (not shown) can interface with the keyed head **228** to rotate it in either direction. Rotating the keyed head **228** will in turn rotate the shaft **224** and the threaded gears **226A** and **226B**. The threaded gears **226A** and **226B** transfer the force to the lower lock supports **20** through the geared bottom face **220**. In the embodiment shown in FIG. **48** the threaded gear **226A** is oriented opposite of the threaded gear **226B**. This allows rotation of the shaft **224** to rotate the lower lock supports **20** in opposite directions relative to each other. It is obvious to those schooled in the art that the threaded gears **226A** and **226B** can be oriented in the same direction if it is desired to rotate the lower lock supports **20** in the same direction. In either case the shaft **224** can be rotated in one direction to rotate the lower lock supports **20** in the locking

direction, and the shaft **224** can be rotated in the opposite direction to rotate the lower lock supports **20** in the unlocking direction.

An unlocking tether as described herein can be engaged and tensioned by any number of means including but not limited to gripping the unlocking tether between articulating grips, a collet or split ring clamp, crimping the unlocking tether to a tensioning wire or rod and cutting the unlocking tether to disengage after use, mounting a magnet on the proximal end **214** (FIG. **46A**) of the unlocking tether and engaging the magnet with a mating magnet attached to a tensioning wire of rod, adding a female or male thread to the proximal end **214** or the unlocking tether and engaging it with a mating thread on the end of a tensioning rod or wire, or providing a continuous unlocking tether all the way to the point external to the body for tensioning and then cutting the unlocking tether near the implant after use to disengage. It is obvious to those schooled in the art that the unlocking tether can alternatively be pushed or compressed rather than tensioned as long as it is configured to rotate the lower lock supports **20A** and **B** in the unlock direction and deliver sufficient load without buckling when pushed.

FIG. **49** illustrates an alternative embodiment of an implant **10M** with a pushable unlocking tether **212a**. In this embodiment, unlocking tether **212a** engages the proximal lower lock support **20B** to rotate it in the unlock direction when the unlocking tether **212a** is advanced towards the proximal lower lock support **20B**. The link **202** transfers that rotation from the following lower lock support **20B** to the leading lower lock support **20A**. The link **202** contains engagement pins **230**, which extend into receiving slots **232** on the lower lock supports **20A** and **20B** in order to transfer the lateral movement of the link **202** into rotation of the lower lock supports **20A** and **20B**. In much the same way, the unlocking tether **212** can contain an engaging pin (not shown) to extend into a receiving slot (not shown) on the following lower lock support **20B** to transfer the lateral compressive force applied to the unlocking tether **212a** into rotation of the lower lock supports **20B**. This is just one method for attaching or engaging the unlocking tether **212** to the lower lock support **20** the numerous methods previously described herein for attaching or engaging the link **202** to the lower lock supports **20** can be used for attaching or engaging the tether **212** as well.

One advantage to pushing the unlocking tether **212a** to unlock the implant **10M** is that the method for engaging the unlocking tether is simplified. Unlocking tether **212a**, which is pushed to unlock the implant **10M** can be contained within the implant **10M** and a push rod (not shown) can be easily directed into the implant **10M** through the unlock port **216** to actuate the unlocking tether **212a** and unlock the implant **10M** such that it can collapse. This eliminates the need to attach to the unlocking tether **212a** which is required when the unlocking tether **212a** is tensioned to unlock the implant **10M**.

The features of the current invention have been described in terms of an implant comprised of a pair of cylinder/piston/lock/and related features, however it is obvious to those schooled in the art that the described features can be included in an implant with only a single set or more than two sets of these features.

A lateral cage implant, as illustrated for exemplary embodiments of the present invention herein, is particularly advantaged by the use of anchors as described herein because the lateral approach to the spine is a long and narrow approach, which limits the ability of the surgeon to use other instrumentation to extend anchors from the cage (as can be done more readily, for example, with an anterior approach

where the access is not as narrow). However, as will be appreciated by persons of ordinary skill in the art, while particular, additional advantages may be presented in connection with the lateral approach and cages designed therefore, anchors according to embodiments of the present invention are advantageous for any approach as they can produce the required extension forces regardless of patient anatomy or other restrictions on the use of alternative extension means by the surgeon.

Elements of the description herein focused on the manner in which the locking elements are configured to lock the implant in extended configurations. Although this locking action resists the forces placed on the implant that would tend to force it back into a collapsed configuration, that is not the only force the locking elements address. Once inserted between vertebral bodies the implant is subject to lateral forces and torsion moments as well as compressive forces. The locking features along with the other elements of the invention are designed to resist all of these forces to provide an implant that provides stable fixation and distraction.

A partial or complete discectomy is usually performed prior to the insertion of the spinal implant having features of the invention between vertebral bodies. The implant is introduced in its unexpanded state to enable it to be inserted posteriorly with minimal trauma to the patient and risk of injury to nerve roots. Once in place the implant can be expanded to provide both medial and lateral spinal correction. The implant has an unexpanded height of about 5 to about 15 mm, typically about 7 mm and is expandable to at least 130% to about 180% of the unexpanded height. Typically the implant is about 9 to about 15 mm wide, typically about 12 mm wide and about 25 to about 55 mm long, typically about 35 mm long to facilitate minimally invasive insertion and thereby minimize trauma to the patient and risk of injury to nerve roots.

Additional details of the implant such as the attachment of hydraulic lines and lines for transmission of a slurry or liquid bone graft material, device and hydraulic fluid delivery accessories and the like can be found in co-pending application Ser. No. 11/535,432 filed on Sep. 26, 2006 and Ser. No. 11,692,800, filed on Mar. 28, 2007, which are incorporated herein by reference.

It will be appreciated that the implant, including its various components should be formed of biocompatible, substantially incompressible material such as PEEK or titanium, and preferably type 6-4 titanium alloy or other suitable materials which will allow for long-term deployment within a patient.

While the invention has been described in connection with what are presently considered to be the most practical and certain preferred embodiments, it is to be understood that the invention is not limited to the disclosed embodiments and alternatives as set forth above, but on the contrary is intended to cover various modifications and equivalent arrangements included within the scope of the following claims.

For example, while implants described herein are expanded by hydraulic fluid, other expansion means may be employed. For example, the screw mechanism described herein may be employed to expand scissor jacks within the implant to engagement adjacent vertebral surfaces. Further, the implant can be provided with load or pressure sensors that register differential pressure and pressure intensity exerted on the engaging surfaces of the SEC by the patient's vertebrae end plates to generate corrective signals, for example by computer control, that are used, e.g. by the surgeon or by a computer-controlled mechanism to realign the patient's spine. The invention may further include a system that makes these adjustments, responsive to sensor signals, in real time

and on a continual basis, such that the shapes of the implant changes to realign the patient's spine or mechanism. Preferably, such system is contemplated for use in setting the positions of the pistons during installation of the implant.

While particular forms of the invention have been illustrated and described herein, it will be apparent that various modifications and improvements can be made to the invention. Additional details of the spinal implant devices may be found in the patents and applications referenced herein. To the extent not otherwise disclosed herein, materials and structure may be of conventional design.

Moreover, individual features of embodiments of the invention may be shown in some drawings and not in others, but those skilled in the art will recognize that individual features of one embodiment of the invention can be combined with any or all the features of another embodiment. Accordingly, it is not intended that the invention be limited to the specific embodiments illustrated. It is therefore intended that this invention be defined by the scope of the appended claims as broadly as the prior art will permit.

Terms such as "element", "member", "component", "device", "means", "portion", "section", "steps" and words of similar import when used herein shall not be construed as invoking the provisions of 35 U.S.C. §112(6) unless the following claims expressly use the terms "means for" or "step for" followed by a particular function without reference to a specific structure or a specific action. All patents and all patent applications referred to above are hereby incorporated by reference in their entirety.

What is claimed is:

1. A spinal implant for placement between first and second vertebral bodies, comprising:

a first member having a surface for engaging a first vertebral body;

a second member cooperating with the first member and having a surface for engaging a second vertebral body;

at least one extendable support element having a contracted configuration to facilitate deployment of the implant between the superior and inferior vertebral bodies and at least one extended configuration to extend the first member away from the second member so that the surface thereof engages the first vertebral body;

a locking system which has a locking element that mechanically engages or interlocks with the extendable support element of the first member to lock the implant between the first and second vertebral bodies in an expanded configuration;

wherein said locking element comprises an upper lock support member having a multi-stepped support surface and a lower lock support member having a multi-stepped support surface configured to engage the multi-stepped support surface of the upper lock support member; and

a locking actuator that is configured to effect relative motion between the upper and lower lock support members when the at least one extendable member is extended so as to lock the implant in an extended configuration by engaging the multi-stepped support surfaces of the upper lock support members and the lower lock support members,

wherein the locking actuator is a biased member configured to move one of the lock support members relative to the other.

2. The spinal implant of claim 1, wherein the lower and upper lock support members have arcuate shapes.

3. The spinal implant of claim 1 wherein the biased member is a spring located in a groove in a base of the implant.

25

4. A spinal implant for placement between adjacent vertebral bodies, comprising:  
 a top end plate for engaging a first adjacent vertebral body;  
 a bottom end plate for engaging a second adjacent vertebral body;  
 at least two extendable piston members having a contracted configuration within the implant to facilitate deployment of the implant between the first and second vertebral bodies and an extended configuration to extend the top end plate into engagement with the first adjacent vertebral body;  
 an upper lock support member associated with each extendable piston member having a multi-stepped support surface;  
 a lower lock support member corresponding to each upper lock support member having a multi-stepped support surface configured to engage the multi-stepped support surface of the upper lock support member;  
 a locking actuator which causes relative motion between the upper and lower lock support members when the at least one extendable member is extended so as to lock the implant in an expanded configuration by engaging the multi-stepped support surfaces of the upper lock support members and the lower lock support members;  
 and  
 a linking member extending between the lower lock support members to link said lower lock members for locking in unison;  
 wherein a spring locking actuator is provided to move the lower lock support member toward the upper lock support when the at least one extendable member is extended.

5. The spinal implant of claim 4 wherein the upper and lower lock support members have matching shapes which facilitate engagement of stepped support surfaces thereof.

6. The spinal implant of claim 5 wherein the upper and lower lock support members have matching arcuate shapes.

7. The spinal implant of claim 4, wherein the bone engaging surface of the first member comprises a bone anchor with a sharpened leading edge configured for anchoring into the bone.

8. The spinal implant of claim 7, wherein the bone anchor includes barbs.

9. A lockable, extendable spinal implant for placement between first and second vertebral bodies, comprising:  
 first and second bone engaging members each having a surface configured to respectively engage opposed first and second vertebral bodies;  
 extension means acting between the first and second bone engaging members to control extension of said bone engaging members between contracted and extended configurations;  
 first and second fixed lock members fixed to one of said first and second bone engaging members and extending towards the opposite bone engaging member, the fixed lock members being spaced apart and each having a fixed locking surface;  
 first and second moveable lock members captured between the first and second bone engaging members for cooperation with the fixed lock members, each moveable lock member having a moveable locking surface configured to engage an opposed fixed locking surface on one said fixed lock member to prevent contraction of said extension means;  
 and  
 a locking actuator configured to engage the moveable locking surfaces with the fixed locking surfaces; and

26

a link member operatively connected between the first and second moveable lock members to coordinate movement therebetween;  
 wherein said extension means comprises first and second extendable support elements, said first and second lock members comprise arcuate members disposed, respectively, in proximity to said first and second extendable support elements; and  
 the locking actuator rotates the moveable lock members to engage the locking surfaces; and  
 wherein the locking actuator comprises a biasing element acting on one of the moveable lock members to bias said member into engagement with its associated fixed lock member and the link member transmits said bias to the other moveable member.

10. The spinal implant of claim 9, wherein said lock members are formed around said extendable support elements.

11. The spinal implant of claim 9, wherein said lock members are formed inside said extendable support elements.

12. The spinal implant of claim 9, wherein the fixed locking surface comprises a multi-stepped support surface and the moveable locking surface comprises a multi-stepped support surface configured to engage the multi-stepped support surface of the fixed lock member.

13. The spinal implant of claim 9, wherein:  
 the link member comprises a rotatable shaft mounted on said bone engaging member opposite the fixed lock members and under the moveable lock members with an end accessible through an opening in the implant;  
 the moveable members have teeth formed around a lower surface thereof; and  
 the lock actuator comprises screw threads spaced apart on said shaft and disposed to engage the teeth on said moveable members such that rotation of the shaft drives the locking surface into or out of engagement as selected by the direction of rotation of the shaft.

14. The spinal implant of claim 9, wherein said extension means comprises a piston and cylinder.

15. The spinal implant of claim 9, wherein said extension means comprises a bellows.

16. The spinal implant of claim 9, wherein said extension means comprises a rotating cam.

17. The spinal implant of claim 9, wherein said extension means comprises a screw lift mechanism.

18. A lockable, extendable spinal implant for placement between first and second vertebral bodies, comprising:  
 first and second bone engaging members each having a surface configured to respectively engage opposed first and second vertebral bodies;  
 extension means acting between the first and second bone engaging members to control extension of said bone engaging members between contracted and extended configurations;  
 first and second fixed lock members fixed to one of said first and second bone engaging members and extending towards the opposite bone engaging member, the fixed lock members being spaced apart and each having a fixed locking surface;  
 first and second moveable lock members captured between the first and second bone engaging members for cooperation with the fixed lock members, each moveable lock member having a moveable locking surface configured to engage an opposed fixed locking surface on one said fixed lock member to prevent contraction of said extension means;  
 and  
 a locking actuator configured to engage the moveable locking surfaces with the fixed locking surfaces;

27

a link member operatively connected between the first and second moveable lock members to coordinate movement therebetween;

wherein said extension means comprises first and second extendable support elements, said first and second lock members comprise arcuate members disposed, respectively, in proximity to said first and second extendable support elements, and the locking actuator rotates the moveable lock members to engage the locking surfaces; and

a tether secured to one said moveable lock member, the tether being configured to permit rotation of the lock member against the locking actuator element to release engagement of the locking surfaces.

19. The spinal implant of claim 18, wherein one said moveable lock member defines a groove at least partially there around and said tether comprises an elongate flexible member at least partially disposed in said groove.

20. The spinal implant of claim 18, wherein said tether comprises an at least substantially rigid member operatively linked to one said moveable lock member such that pressure applied to said tether rotates the linked lock members to an unlocked configuration.

21. The spinal implant of claim 18, wherein each said moveable lock member defines a groove formed at least partially there around and said link member comprises a flexible element disposed in said grooves.

22. A lockable, extendable spinal implant for placement between first and second vertebral bodies, comprising:

first and second bone engaging members each having a surface configured to respectively engage opposed first and second vertebral bodies;

extension means acting between the first and second bone engaging members to control extension of said bone engaging members between contracted and extended configurations;

first and second fixed lock members fixed to one of said first and second bone engaging members and extending towards the opposite bone engaging member, the fixed lock members being spaced apart and each having a fixed locking surface;

first and second moveable lock members captured between the first and second bone engaging members for cooperation with the fixed lock members, each moveable lock member having a moveable locking surface configured to engage an opposed fixed locking surface on one said fixed lock member to prevent contraction of said extension means;

a locking actuator configured to engage the moveable locking surfaces with the fixed locking surfaces; and

28

a link member operatively connected between the first and second moveable lock members to coordinate movement therebetween;

wherein said link member comprises a substantially rigid member pivotably secured to each said moveable lock member.

23. A lockable, extendable spinal implant for placement between first and second vertebral bodies, comprising:

first and second bone engaging members each having a surface configured to respectively engage opposed first and second vertebral bodies;

first and second pistons disposed on one said bone engaging member and cooperating with mating cylinders disposed on the opposite bone engaging member, said pistons moveable between a contracted configuration within said cylinders and an extended configuration extending from said cylinders;

first and second arcuate, fixed lock members, each having a fixed locking surface, mounted to one of said bone engaging members, each disposed inside one said piston, the fixed lock members extending towards the opposite bone engaging member;

first and second moveable lock members, each formed inside one said cylinder for cooperation with the fixed lock members, each moveable lock member having a moveable locking surface configured to engage an opposed fixed locking surface on one said fixed lock member to prevent contraction of said extension means; at least one biasing element acting on at least one said moveable lock member to bias said member into engagement with its associated fixed lock member; and a link member operatively connected between the first and second moveable lock members to coordinate movement therebetween and force the other moveable lock member into engagement with its associated fixed lock.

24. The spinal implant of claim 23, further comprising a tether secured to one said moveable lock member, the tether being configured to permit rotation of the moveable lock members against the biasing element to release engagement of the locking surfaces.

25. The spinal implant of claim 23, wherein each said moveable lock member defines a groove formed at least partially there around and said link member comprises a flexible element disposed in said grooves.

26. The spinal implant of claim 23, wherein said link member comprises a substantially rigid member pivotably secured to each said moveable lock member.

\* \* \* \* \*