



US008992620B2

(12) **United States Patent**
Ashley et al.

(10) **Patent No.:** **US 8,992,620 B2**
(45) **Date of Patent:** **Mar. 31, 2015**

- (54) **ADJUSTABLE DISTRACTION CAGE WITH LINKED LOCKING MECHANISMS**
- (71) Applicant: **CoAlign Innovations, Inc.**, Brisbane, CA (US)
- (72) Inventors: **John E. Ashley**, Danville, CA (US); **Philip J. Simpson**, Escondido, CA (US); **Walter Dean Gillespie**, Carlsbad, CA (US); **Damien J. Shulock**, San Francisco, CA (US); **Murali Kadaba**, Emerald Hills, CA (US); **David G. Matsuura**, Encinitas, CA (US); **George A. Mansfield, III**, San Diego, CA (US); **Thomas Grotz**, Novato, CA (US); **Rudy Pretti**, Auburn, CA (US); **Dennis Crandall**, Mesa, AZ (US)

- (73) Assignee: **CoAlign Innovations, Inc.**, Brisbane, CA (US)
- (*) Notice: Subject to any disclaimer, the term of this patent is extended or adjusted under 35 U.S.C. 154(b) by 0 days.

(21) Appl. No.: **13/843,390**
(22) Filed: **Mar. 15, 2013**

(65) **Prior Publication Data**
US 2013/0253650 A1 Sep. 26, 2013

Related U.S. Application Data
(63) Continuation-in-part of application No. 12/787,281, filed on May 25, 2010, now Pat. No. 8,696,751, which
(Continued)

(51) **Int. Cl.**
A61F 2/44 (2006.01)
A61F 2/30 (2006.01)
(Continued)

(52) **U.S. Cl.**
CPC *A61F 2/4455* (2013.01); *A61F 2/441* (2013.01); *A61F 2/442* (2013.01); *A61F 2/30742* (2013.01);
(Continued)

(58) **Field of Classification Search**
USPC 623/17.11-17.16; 606/246-249
See application file for complete search history.

(56) **References Cited**

U.S. PATENT DOCUMENTS

3,875,595 A 4/1975 Froning
4,932,975 A 6/1990 Main et al.

(Continued)

FOREIGN PATENT DOCUMENTS

EP 1415624 5/2004
EP 1442715 8/2004

(Continued)

OTHER PUBLICATIONS

International Search Report and Written Opinion date mailed Jun. 5, 2009 for related PCT/US2009/000974.

(Continued)

Primary Examiner — Alvin Stewart
(74) *Attorney, Agent, or Firm* — Lerner, David, Littenberg, Krumholz & Mentlik, LLP

(57) **ABSTRACT**

A spinal implant which is configured to be deployed between adjacent vertebral bodies. The implant has at least one extendable support element with a retracted configuration to facilitate deployment of the implant and an extended configuration so as to expand the implant and effectively distract the disc space, stabilize the motion segments and eliminate pathologic spine motion. The implant has a minimal dimension in its unexpanded state that is smaller than the dimensions of the neuroforamen through which it typically passes to be deployed within the intervertebral space. The implant is provided with a locking system having a plurality of linked locking elements that work in unison to lock the implant in an extended configuration. Bone engaging anchors also may be provided to ensure secure positioning.

17 Claims, 50 Drawing Sheets

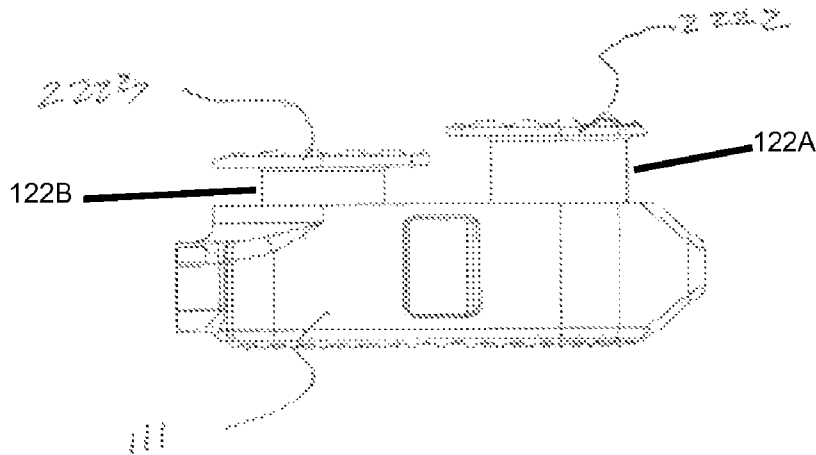

Related U.S. Application Data

is a continuation-in-part of application No. PCT/US2009/067446, filed on Dec. 10, 2009, and a continuation-in-part of application No. 12/380,840, filed on Mar. 4, 2009, now abandoned.

(60) Provisional application No. 61/201,518, filed on Dec. 10, 2008.

(51) **Int. Cl.**

A61F 2/46 (2006.01)

A61F 2/48 (2006.01)

(52) **U.S. Cl.**

CPC *A61F 2/4611* (2013.01); *A61F 2002/30079* (2013.01); *A61F 2002/3008* (2013.01); *A61F 2002/30133* (2013.01); *A61F 2002/30365* (2013.01); *A61F 2002/30405* (2013.01); *A61F 2002/30476* (2013.01); *A61F 2002/30484* (2013.01); *A61F 2002/30499* (2013.01); *A61F 2002/30505* (2013.01); *A61F 2002/30514* (2013.01); *A61F 2002/30522* (2013.01); *A61F 2002/30525* (2013.01); *A61F 2002/3055* (2013.01); *A61F 2002/30551* (2013.01); *A61F 2002/30565* (2013.01); *A61F 2002/30579* (2013.01); *A61F 2002/30581* (2013.01); *A61F 2002/30589* (2013.01); *A61F 2002/30601* (2013.01); *A61F 2002/30841* (2013.01); *A61F 2002/482* (2013.01); *A61F 2002/485* (2013.01); *A61F 2310/00017* (2013.01); *A61F 2310/00023* (2013.01)

USPC **623/17.16**

(56)

References Cited

U.S. PATENT DOCUMENTS

4,969,888 A 11/1990 Scholten et al.
 5,236,460 A 8/1993 Barber
 5,653,763 A 8/1997 Errico et al.
 5,665,122 A 9/1997 Kambin
 5,723,013 A 3/1998 Jeanson et al.
 5,827,328 A 10/1998 Buttermann
 5,865,848 A 2/1999 Baker
 5,916,267 A 6/1999 Tienboon
 5,980,522 A 11/1999 Koros et al.
 5,989,290 A 11/1999 Biedermann et al.
 6,039,761 A 3/2000 Li et al.
 6,102,950 A 8/2000 Vaccaro
 6,127,597 A 10/2000 Beyar et al.
 6,176,881 B1 1/2001 Schar et al.
 6,193,756 B1 2/2001 Studer et al.
 6,214,012 B1 4/2001 Karpman et al.
 6,296,665 B1 10/2001 Strnad et al.
 6,371,989 B1 4/2002 Chauvin et al.
 6,375,682 B1 4/2002 Fleischmann et al.
 6,375,683 B1 4/2002 Crozet et al.
 6,395,032 B1 5/2002 Gauchet
 6,454,806 B1* 9/2002 Cohen et al. 623/17.15
 6,562,074 B2 5/2003 Gerbec et al.
 6,582,467 B1 6/2003 Teitelbaum et al.
 6,585,699 B2 7/2003 Ljunggreen et al.
 6,692,495 B1 2/2004 Zacouto
 6,719,796 B2* 4/2004 Cohen et al. 623/17.15
 6,723,126 B1 4/2004 Berry
 6,730,088 B2 5/2004 Yeh
 6,764,491 B2 7/2004 Frey et al.
 6,830,570 B1 12/2004 Frey et al.
 6,835,207 B2 12/2004 Zacouto et al.
 6,866,682 B1 3/2005 An et al.
 6,875,235 B2 4/2005 Ferree
 6,953,477 B2 10/2005 Berry
 6,960,232 B2 11/2005 Lyons et al.

6,981,989 B1 1/2006 Fleischmann et al.
 7,001,431 B2 2/2006 Bao et al.
 7,018,415 B1* 3/2006 McKay 623/17.15
 7,018,416 B2 3/2006 Hanson et al.
 7,060,073 B2 6/2006 Frey et al.
 7,066,958 B2 6/2006 Ferree
 7,094,257 B2 8/2006 Mujwid et al.
 7,166,110 B2 1/2007 Yundt
 7,204,853 B2 4/2007 Gordon et al.
 7,214,243 B2* 5/2007 Taylor 623/17.11
 7,217,293 B2 5/2007 Branch, Jr.
 7,282,063 B2 10/2007 Cohen et al.
 7,291,150 B2 11/2007 Graf
 7,291,158 B2 11/2007 Crow et al.
 7,316,686 B2 1/2008 Dorchak et al.
 7,316,714 B2 1/2008 Gordon et al.
 7,351,261 B2 4/2008 Casey
 7,407,513 B2 8/2008 Alleyne et al.
 7,419,505 B2 9/2008 Fleischmann et al.
 7,452,359 B1 11/2008 Michelson
 7,470,273 B2 12/2008 Dougherty-Shah
 7,481,812 B2 1/2009 Frey et al.
 7,485,145 B2 2/2009 Purcell
 7,507,241 B2 3/2009 Levy et al.
 7,520,900 B2 4/2009 Trieu
 7,563,284 B2 7/2009 Coppes et al.
 7,563,286 B2 7/2009 Gerber et al.
 7,621,956 B2 11/2009 Paul et al.
 7,628,815 B2 12/2009 Baumgartner et al.
 7,670,359 B2 3/2010 Yundt
 7,708,779 B2 5/2010 Edie et al.
 7,722,674 B1* 5/2010 Grotz 623/17.11
 7,731,752 B2 6/2010 Edie et al.
 7,731,753 B2 6/2010 Reo et al.
 7,771,480 B2 8/2010 Navarro et al.
 7,794,501 B2 9/2010 Edie et al.
 7,806,935 B2 10/2010 Navarro et al.
 7,819,921 B2 10/2010 Grotz
 7,824,444 B2 11/2010 Biscup et al.
 7,824,445 B2 11/2010 Biro et al.
 7,854,766 B2* 12/2010 Moskowitz et al. 623/17.15
 7,862,618 B2 1/2011 White et al.
 7,883,543 B2 2/2011 Sweeney
 7,935,124 B2 5/2011 Frey et al.
 7,967,863 B2 6/2011 Frey et al.
 7,967,867 B2 6/2011 Barreiro et al.
 7,985,231 B2 7/2011 Sankaran
 7,985,256 B2* 7/2011 Grotz et al. 623/17.11
 8,021,395 B2 9/2011 Ben-Mokhtar et al.
 8,025,680 B2 9/2011 Hayes et al.
 8,057,549 B2 11/2011 Butterman et al.
 8,062,368 B2 11/2011 Heinz et al.
 8,062,373 B2 11/2011 Fabian, Jr.
 8,105,382 B2 1/2012 Olmos et al.
 8,153,785 B2 4/2012 Khire et al.
 8,187,331 B2 5/2012 Strohkirch, Jr. et al.
 8,192,495 B2* 6/2012 Simpson et al. 623/17.15
 8,267,939 B2 9/2012 Cipoletti et al.
 8,273,124 B2 9/2012 Renganath et al.
 8,303,663 B2* 11/2012 Jimenez et al. 623/17.16
 8,353,961 B2 1/2013 McClintock et al.
 8,366,777 B2 2/2013 Matthis et al.
 8,394,143 B2* 3/2013 Grotz et al. 623/17.11
 8,435,296 B2* 5/2013 Kadaba et al. 623/17.12
 8,454,695 B2* 6/2013 Grotz et al. 623/17.11
 8,696,751 B2* 4/2014 Ashley et al. 623/17.16
 2001/0056302 A1 12/2001 Boyer et al.
 2002/0128716 A1 9/2002 Cohen et al.
 2002/0138146 A1* 9/2002 Jackson 623/17.15
 2002/0151976 A1 10/2002 Foley et al.
 2003/0114899 A1 6/2003 Woods et al.
 2004/0030346 A1 2/2004 Frey et al.
 2004/0088054 A1 5/2004 Berry
 2004/0097928 A1 5/2004 Zdeblick et al.
 2004/0133273 A1 7/2004 Cox
 2004/0153065 A1 8/2004 Lim
 2004/0186576 A1 9/2004 Biscup et al.
 2005/0033437 A1 2/2005 Bao et al.
 2005/0043800 A1 2/2005 Paul et al.

(56)

References Cited

U.S. PATENT DOCUMENTS

2005/0049590 A1 3/2005 Alleyne et al.
 2005/0085910 A1 4/2005 Sweeney
 2005/0107881 A1 5/2005 Alleyne et al.
 2005/0113842 A1 5/2005 Bertagnoli et al.
 2005/0197702 A1 9/2005 Coppes et al.
 2005/0216084 A1 9/2005 Fleischmann et al.
 2005/0229433 A1 10/2005 Cachia
 2005/0251260 A1 11/2005 Gerber et al.
 2005/0273169 A1 12/2005 Purcell
 2005/0273170 A1 12/2005 Navarro et al.
 2005/0273171 A1 12/2005 Gordon et al.
 2006/0036259 A1 2/2006 Carl et al.
 2006/0085073 A1 4/2006 Raiszadeh
 2006/0089719 A1 4/2006 Trieu
 2006/0106416 A1 5/2006 Raymond et al.
 2006/0116767 A1 6/2006 Magerl et al.
 2006/0142860 A1 6/2006 Navarro et al.
 2006/0149377 A1 7/2006 Navarro et al.
 2006/0167547 A1 7/2006 Suddaby
 2006/0200244 A1 9/2006 Assaker
 2006/0235426 A1 10/2006 Lim et al.
 2006/0235535 A1 10/2006 Ferree et al.
 2006/0264968 A1 11/2006 Frey et al.
 2007/0050030 A1 3/2007 Kim
 2007/0050033 A1 3/2007 Reo et al.
 2007/0073395 A1 3/2007 Baumgartner et al.
 2007/0093901 A1* 4/2007 Grotz et al. 623/17.11
 2007/0093903 A1 4/2007 Cheng
 2007/0123987 A1 5/2007 Bernstein
 2007/0179611 A1 8/2007 DiPoto et al.
 2007/0233254 A1* 10/2007 Grotz et al. 623/17.11
 2007/0255409 A1 11/2007 Dickson et al.
 2007/0255413 A1 11/2007 Edie et al.
 2007/0255415 A1 11/2007 Edie et al.
 2007/0270961 A1 11/2007 Ferguson
 2007/0270964 A1 11/2007 Strohkirch et al.
 2007/0288092 A1 12/2007 Bambakidis
 2008/0021555 A1 1/2008 White et al.
 2008/0021556 A1 1/2008 Edie
 2008/0058930 A1 3/2008 Edie et al.
 2008/0058931 A1 3/2008 White et al.
 2008/0065082 A1 3/2008 Chang et al.
 2008/0065220 A1 3/2008 Alleyne et al.
 2008/0065221 A1 3/2008 Alleyne et al.
 2008/0077150 A1 3/2008 Nguyen
 2008/0086276 A1 4/2008 Naka et al.
 2008/0097441 A1 4/2008 Hayes et al.
 2008/0103601 A1* 5/2008 Biro et al. 623/17.16
 2008/0114467 A1 5/2008 Capote et al.
 2008/0140207 A1 6/2008 Olmos et al.
 2008/0147193 A1 6/2008 Matthis et al.
 2008/0147194 A1* 6/2008 Grotz et al. 623/17.16
 2008/0161933 A1* 7/2008 Grotz et al. 623/17.16
 2008/0177387 A1 7/2008 Parimore et al.
 2008/0215153 A1 9/2008 Buttermann et al.
 2008/0281424 A1 11/2008 Parry et al.
 2008/0288073 A1 11/2008 Renganath et al.
 2008/0300598 A1 12/2008 Barreiro et al.
 2009/0005819 A1 1/2009 Ben-Mokhtar et al.
 2009/0005874 A1 1/2009 Fleischmann et al.
 2009/0018661 A1 1/2009 Kim et al.
 2009/0043312 A1 2/2009 Koulisis et al.
 2009/0048676 A1 2/2009 Fabian, Jr.
 2009/0105836 A1 4/2009 Frey et al.
 2009/0171389 A1 7/2009 Sankaran
 2009/0204215 A1 8/2009 McClintock et al.
 2009/0216331 A1 8/2009 Grotz et al.
 2009/0222100 A1 9/2009 Cipoletti et al.
 2009/0270987 A1 10/2009 Heinz et al.
 2010/0016970 A1 1/2010 Kapitan et al.
 2010/0057204 A1* 3/2010 Kadaba et al. 623/17.12
 2010/0145455 A1* 6/2010 Simpson et al. 623/17.16
 2010/0249930 A1 9/2010 Myers
 2011/0130835 A1 6/2011 Ashley et al.
 2011/0137416 A1 6/2011 Myers

2011/0270398 A1* 11/2011 Grotz et al. 623/17.12
 2011/0288646 A1 11/2011 Mosowitz et al.
 2012/0059469 A1 3/2012 Myers et al.
 2012/0116518 A1 5/2012 Grotz et al.
 2012/0130387 A1 5/2012 Simpson et al.
 2012/0245695 A1 9/2012 Simpson et al.
 2012/0283830 A1 11/2012 Myers
 2013/0096677 A1 4/2013 Myers et al.
 2013/0158669 A1 6/2013 Sungarian et al.
 2013/0197642 A1 8/2013 Ernst
 2013/0197647 A1 8/2013 Wolters et al.
 2013/0197648 A1 8/2013 Boehm et al.
 2013/0204368 A1 8/2013 Prevost
 2013/0204374 A1 8/2013 Milella, Jr.
 2013/0253650 A1 9/2013 Ashley et al.

FOREIGN PATENT DOCUMENTS

JP 2001-518824 A 10/2001
 JP 2008-502372 A 1/2008
 WO 03003951 A1 1/2003
 WO 2004016205 A2 2/2004
 WO 2004016250 A1 2/2004
 WO 2006044786 A2 4/2006
 WO 2007124078 A2 11/2007
 WO 2008011371 1/2008
 WO 2008039811 4/2008
 WO 2008086276 A2 7/2008
 WO 2008112607 A2 9/2008
 WO 2008121251 10/2008
 WO 2008148210 A1 12/2008
 WO 2009033100 A1 3/2009
 WO 2009064787 A2 5/2009
 WO 2009105182 8/2009
 WO 2009114381 A1 9/2009
 WO 2010068725 6/2010
 WO 2011011609 A2 1/2011
 WO 2011150077 A1 12/2011

OTHER PUBLICATIONS

Response to Election/Restriction Requirement dated Mar. 27, 2012 in related U.S. Appl. No. 12/878,281, filed May 25, 2010.
 Office Action dated Apr. 9, 2012 in related U.S. Appl. No. 12/878,281, filed May 25, 2010.
 Translated Second Office Action dated Apr. 26, 2012 in related China Application No. 200880016846.7.
 Office Action dated Jun. 20, 2012 in related U.S. Appl. No. 13/183,080, filed Jul. 14, 2011.
 Office Action dated Jun. 20, 2012 in related U.S. Appl. No. 13/311,487, filed Dec. 5, 2011.
 Final Office Action dated Jun. 19, 2012 in related U.S. Appl. No. 11/981,150, filed Oct. 31, 2007.
 Office Action dated Jun. 1, 2012 in related U.S. Appl. No. 12/548,260, filed Aug. 26, 2009.
 Examination Report dated Jul. 17, 2012, in European Patent Application No. 09712948.0.
 Response to Office Action dated Oct. 9, 2012, in related U.S. Appl. No. 12/787,281, filed May 25, 2010.
 Response to Office Action dated Oct. 15, 2012, in related U.S. Appl. No. 12/548,260, filed Aug. 26, 2009.
 Response to Final Office Action dated Oct. 18, 2012, in connection with related U.S. Appl. No. 11/981,150, filed Oct. 31, 2007.
 Notice of Allowance date mailed Nov. 9, 2012, in connection with related U.S. Appl. No. 11/981,150, filed Oct. 31, 2007.
 Response to Office Action dated Oct. 22, 2012, in connection with related U.S. Appl. No. 13/311,487, filed Dec. 5, 2011.
 Response to Office Action dated Oct. 9, 2012, in connection with related U.S. Appl. No. 12/787,281, filed May 25, 2010.
 Final Office Action dated Jan. 2, 2013, in connection with related U.S. Appl. No. 12/787,281, filed May 25, 2010.
 Response to Office Action dated Oct. 22, 2012, in connection with related U.S. Appl. No. 13/183,080, filed Jul. 14, 2011.
 Response to Office Action dated Oct. 15, 2012, in connection with related U.S. Appl. No. 12/548,260, filed Aug. 26, 2009.

(56)

References Cited

OTHER PUBLICATIONS

Final Office Action dated Oct. 30, 2012, in connection with related U.S. Appl. No. 12/548,260, filed Aug. 26, 2009.

Response to Final Office Action dated Dec. 31, 2012, in connection with related U.S. Appl. No. 12/548,260, filed Aug. 26, 2009.

Supplemental Response and Amendment after Final Office Action dated Jan. 4, 2013, in connection with related U.S. Appl. No. 12/548,260, filed Aug. 26, 2009.

Office Action dated Feb. 11, 2013, in connection with related European Patent Application No. 08727082.3 filed Mar. 21, 2008.

Response to Final Office Action dated Mar. 1, 2013, in connection with related U.S. Appl. No. 12/787,281, filed May 25, 2010.

Office Action dated May 2, 2013, in connection with related Japanese Patent Application No. 2010-547621 filed Feb. 17, 2009.

First Office Action dated Mar. 6, 2013, in connection with related Chinese Patent Application No. 200980106122.6 filed Feb. 17, 2009.

Restricted Requirement dated Dec. 27, 2010 in related U.S. Appl. No. 12/072,044 entitled "Spinal Implant With Expandable Fixation."

Amendment and Response to Restriction Requirement dated Jan. 27, 2011 in related U.S. Appl. No. 12/072,044, filed Feb. 22, 2008 entitled "Spinal Implant With Expandable Fixation."

Office Action dated May 9, 2011 in related U.S. Appl. No. 12/072,044, filed Feb. 22, 2008 entitled "Spinal Implant With Expandable Fixation."

Response to Office Action dated Jul. 29, 2012 in related U.S. Appl. No. 12/072,044, filed Feb. 22, 2008 entitled "Spinal Implant With Expandable Fixation."

Final Office Action dated Nov. 19, 2012 in connection with related U.S. Appl. No. 12/072,044, filed Feb. 22, 2008 entitled "Spinal Implant With Expandable Fixation."

Response to Final Office Action dated Jan. 21, 2013 in connection with related U.S. Appl. No. 12/072,044, filed Feb. 22, 2008 entitled "Spinal Implant With Expandable Fixation."

Advisory Action dated Feb. 14, 2013 in connection with related U.S. Appl. No. 12/072,044, filed Feb. 22, 2008 entitled "Spinal Implant With Expandable Fixation."

Second Response to Final Office Action dated Mar. 18, 2013 in connection with related U.S. Appl. No. 12/072,044, filed Feb. 22, 2008 entitled "Spinal Implant With Expandable Fixation."

Advisory Action dated Apr. 17, 2013 in connection with related U.S. Appl. No. 12/072,044, filed Feb. 22, 2008 entitled "Spinal Implant With Expandable Fixation."

Third Response After Final Action dated Apr. 19, 2013 in connection with related U.S. Appl. No. 12/072,044, filed Feb. 22, 2008 entitled "Spinal Implant With Expandable Fixation."

Related U.S. Appl. No. 11/535,432, filed Sep. 26, 2006, in the name of Thomas Grotz et al., entitled, "Selectively Expanding Spine Cage, Hydraulically Controllable in Three Dimensions for Enhanced Spinal Fusion."

Related U.S. Appl. No. 12/787,281, filed May 25, 2010, in the name of John E. Ashley et al., entitled "Adjustable Distraction Cage with Linked Locking Mechanism."

Related U.S. Appl. No. 12/380,840, filed Mar. 4, 2009, in the name of Philip J. Simpson et al., entitled "Lockable Spinal Implant."

Related International Application No. PCT/US2009/067446 filed Dec. 10, 2009, in the name of Innvotec Surgical, Inc., entitled "Lockable Expanding Spine Cage."

Related International Application No. PCT/US2009/00974 filed Feb. 17, 2009, in the name of Innvotec Surgical, Inc., entitled "Spinal Implant with Expandable Fixation."

Response to Office Action dated Dec. 16, 2010 in related U.S. Appl. No. 11/692,800, filed Mar. 28, 2007, in the name of R. Thomas Grotz et al., entitled "Selectively Expanding Spine Cage, Hydraulically Controllable in Three Dimensions for Vertebral Body Replacement."

Related International Application No. PCT/US2008/003776 filed Mar. 21, 2008, in the name of Innvotec Surgical, Inc., entitled "Selectively Expanding Spine Cage, Hydraulically Controllable in Three Dimensions for Vertebral Body Replacement."

International Search Report and Written Opinion date mailed Jun. 30, 2009, in related International Application No. PCT/US2008/003776 filed Mar. 21, 2008.

Related U.S. Appl. No. 11/692,800, filed Mar. 28, 2007, in the name of R. Thomas Grotz et al., entitled "Selectively Expanding Spine Cage, Hydraulically Controllable in Three Dimensions for Vertebral Body Replacement."

Office Action dated Sep. 16, 2010 in related U.S. Appl. No. 11/692,800, filed Mar. 28, 2007, in the name of R. Thomas Grotz et al., entitled "Selectively Expanding Spine Cage, Hydraulically Controllable in Three Dimensions for Vertebral Body Replacement."

Related U.S. Appl. No. 11/981,150, filed Oct. 31, 2007, in the name of R. Thomas Grotz et al., entitled "Selectively Expanding Spine Cage, Hydraulically Controllable in Three Dimensions for Vertebral Body Replacement."

Related U.S. Appl. No. 12/548,260, filed Aug. 26, 2009, in the name of Murali Kadaba et al., entitled "Hydraulically Actuated Expanding Spine Cage with Extendable Locking Anchor."

Related U.S. Appl. No. 11/981,452, filed Oct. 31, 2007, in the name of R. Thomas Grotz et al., entitled "Selectively Expanding Spine Cage, Hydraulically Controllable in Three Dimensions for Vertebral Body Replacement."

Related U.S. Appl. No. 12/384,622, filed Apr. 7, 2009, in the name of Philip J. Simpson et al., entitled "Lockable Spinal Implant."

Preliminary Amendment mailed on Dec. 4, 2007 in related U.S. Appl. No. 11/535,432, entitled "Selectively Expanding Spine Cage, Hydraulically Controllable in Three Dimensions for Enhanced Spinal Fusion."

Second Preliminary Amendment dated Mar. 18, 2008 in related U.S. Appl. No. 11/535,432, entitled "Selectively Expanding Spine Cage, Hydraulically Controllable in Three Dimensions for Enhanced Spinal Fusion."

Third Preliminary Amendment dated Aug. 7, 2008 in related U.S. Appl. No. 11/535,432, entitled "Selectively Expanding Spine Cage, Hydraulically Controllable in Three Dimensions for Enhanced Spinal Fusion."

Restriction Requirement mailed on Mar. 17, 2010 in related U.S. Appl. No. 11/535,432, entitled "Selectively Expanding Spine Cage, Hydraulically Controllable in Three Dimensions for Enhanced Spinal Fusion."

Response to Restriction Requirement dated Mar. 31, 2010 in related U.S. Appl. No. 11/535,432, entitled "Selectively Expanding Spine Cage, Hydraulically Controllable in Three Dimensions for Enhanced Spinal Fusion."

Office Action dated Jul. 9, 2010 in related U.S. Appl. No. 11/535,432, entitled "Selectively Expanding Spine Cage, Hydraulically Controllable in Three Dimensions for Enhanced Spinal Fusion."

Response to Office Action dated Oct. 4, 2010 in related U.S. Appl. No. 11/535,432, entitled "Selectively Expanding Spine Cage, Hydraulically Controllable in Three Dimensions for Enhanced Spinal Fusion."

Preliminary Amendment mailed on Dec. 11, 2009 in related U.S. Appl. No. 12/548,260, entitled "Hydraulically Actuated Expanding Spine Cage with Extendable Locking Anchor."

Preliminary Amendment mailed on Oct. 31, 2007 in related U.S. Appl. No. 11/981,452, filed Oct. 31, 2007, entitled "Selectively Expanding Spine Cage, Hydraulically Controllable in Three Dimensions for Vertebral Body Replacement."

Preliminary Amendment dated Oct. 31, 2007 in related U.S. Appl. No. 11/981,150, filed Oct. 31, 2007, entitled "Selectively Expanding Spine Cage, Hydraulically Controllable in Three Dimensions for Vertebral Body Replacement."

International Search Report and Written Opinion dated Apr. 10, 2008 in related International Application No. PCT/US2007/079474.

Terminal Disclaimer dated Dec. 16, 2010 in related U.S. Appl. No. 11/692,800, filed Mar. 28, 2007, in the name of R. Thomas Grotz et al., entitled "Selectively Expanding Spine Cage, Hydraulically Controllable in Three Dimensions for Vertebral Body Replacement."

Response to Office Action dated Dec. 16, 2010, in related U.S. Appl. No. 11/692,800 entitled "Selectively Expanding Spine Cage, Hydraulically Controllable in Three Dimensions for Vertebral Body Replacement."

(56)

References Cited

OTHER PUBLICATIONS

International Search Report and Written Opinion dated Nov. 11, 2010 in International Application No. PCT/US2010/031247 entitled "Insertion Handle for Implant."

Final Office Action dated Feb. 1, 2011, in related U.S. Appl. No. 11/535,432 entitled "Selectively Expanding Spine Cage, Hydraulically Controllable in Three Dimensions for Enhanced Spinal Fusion."

Final Office Action dated Mar. 2, 2011, in related U.S. Appl. No. 11/692,800 entitled "Selectively Expanding Spine Cage, Hydraulically Controllable in Three Dimensions for Vertebral Body Replacement."

Response to Final Office Action dated Mar. 23, 2011, in related U.S. Appl. No. 11/535,432 entitled "Selectively Expanding Spine Cage, Hydraulically Controllable in Three Dimensions for Enhanced Spinal Fusion."

Office Action dated Apr. 5, 2011, in related U.S. Appl. No. 11/981,150 entitled "Selectively Expanding Spine Cage, Hydraulically Controllable in Three Dimensions for Enhanced Spinal Fusion."

Office Action dated Mar. 31, 2011, in related U.S. Appl. No. 11/981,452 entitled "Selectively Expanding Spine Cage, Hydraulically Controllable in Three Dimensions for Vertebral Body Replacement."

Restriction Requirement dated Apr. 4, 2011, in related U.S. Appl. No. 12/384,622 entitled "Lockable Spinal Implant."

Notice of Allowance mailed on Apr. 13, 2011, in related U.S. Appl. No. 11/535,432 entitled "Selectively Expanding Spine Cage, Hydraulically Controllable in Three Dimensions for Enhanced Spinal Fusion."

Restriction Requirement dated May 2, 2011, in related U.S. Appl. No. 12/380,840 entitled "Lockable Spinal Implant."

Response to Final Office Action dated May 2, 2011, in related U.S. Appl. No. 11/692,800 entitled "Selectively Expanding Spine Cage, Hydraulically Controllable in Three Dimensions for Vertebral Body Replacement."

Non-Final Rejection Office Action dated Feb. 13, 2014 in related U.S. Appl. No. 12/072,044, filed Feb. 22, 2008.

Office Action dated Jun. 26, 2013, in connection with related U.S. Appl. No. 12/787,281, filed May 25, 2010.

Response to Office Action dated Sep. 26, 2013, in connection with related U.S. Appl. No. 12/787,281, filed May 25, 2010.

Notice of Allowance dated Nov. 22, 2013, in connection with related U.S. Appl. No. 12/787,281, filed May 25, 2010.

Office Action dated Dec. 27, 2013, in connection with related U.S. Appl. No. 13/799,047, filed Mar. 13, 2013.

Office Action dated Jan. 6, 2014, in connection with related U.S. Appl. No. 13/486,679, filed Jun. 1, 2012.

Appellate Brief dated Sep. 13, 2013, in connection with related U.S. Appl. No. 12/072,044, filed Feb. 22, 2008.

Extended European Search Report for Application No. 11787340.6 dated Jun. 25, 2014.

International Search Report and Written Opinion dated Sep. 22, 2011 in related International Application No. PCT/US2011/037929.

International Search Report and Written Opinion dated May 6, 2009. In related International Application No. PCT/US2009/000974 filed Feb. 17, 2009.

International Search Report and Written Opinion dated May 6, 2009, in related International Application No. PCT/US2009/000974 filed Feb. 17, 2009.

International Search Report and Written Opinion dated Jun. 30, 2009, in related International Application No. PCT/US2008/003776 filed Mar. 21, 2008.

International Search Report and Written Opinion dated Aug. 13, 2010, in related International Application No. PCT/US2009/067446 filed Dec. 10, 2009.

International Search Report & Written Opinion for Application No. PCT/US2009/000974 dated Jun. 5, 2009.

Extended European Search Report for Application No. EP14159619 dated Jun. 12, 2014.

* cited by examiner

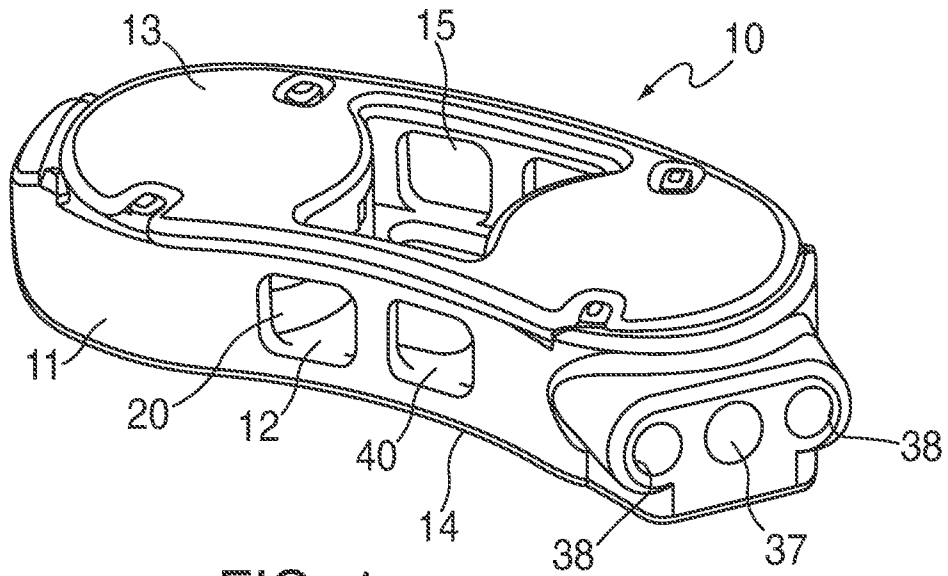

FIG. 1

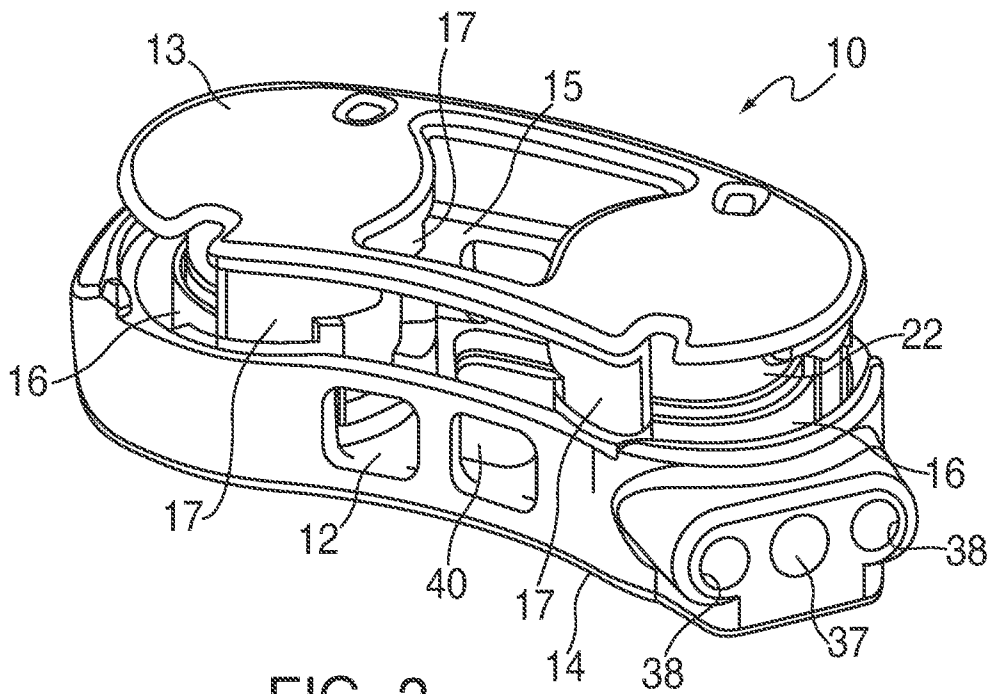

FIG. 2

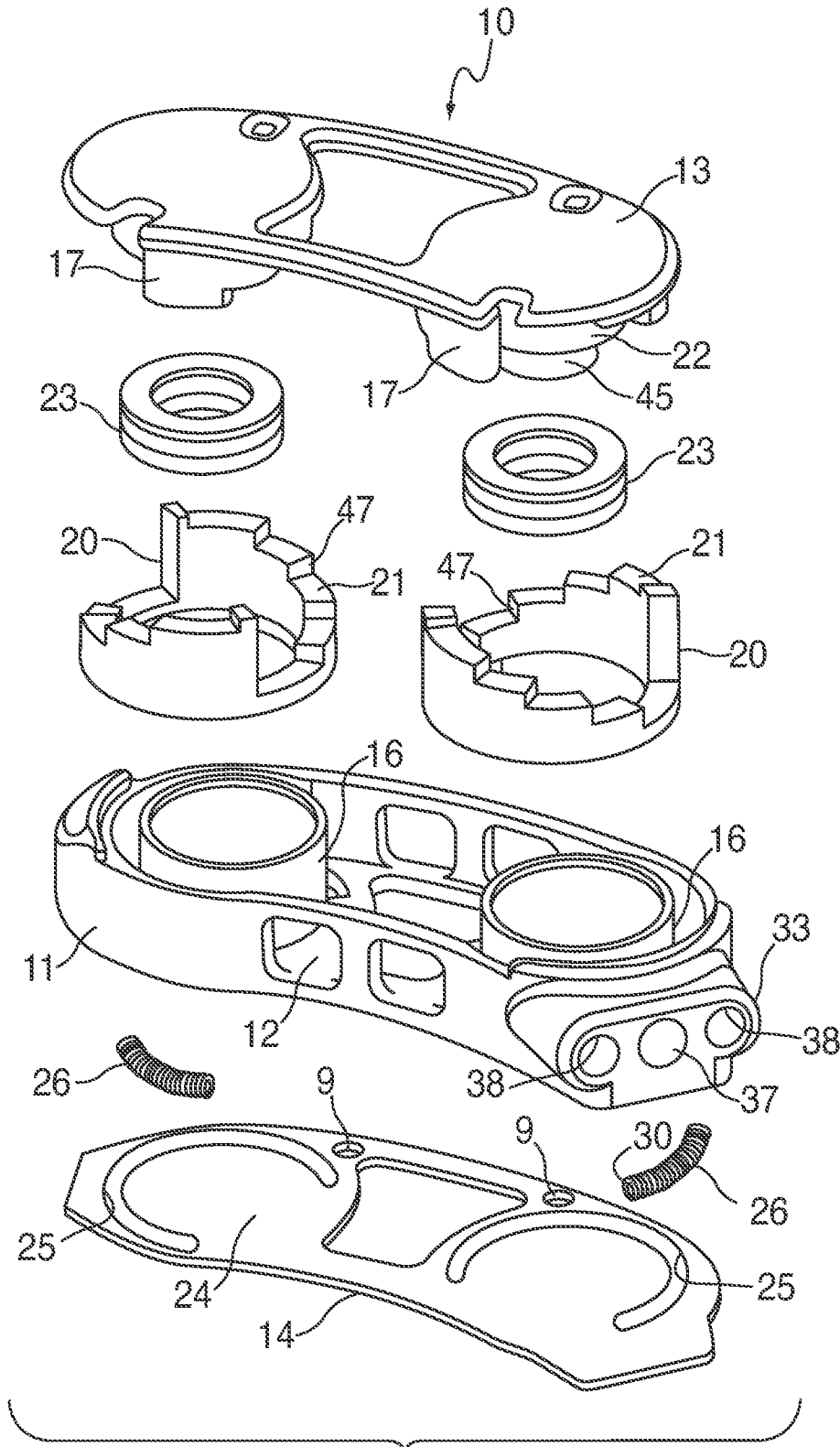

FIG. 3

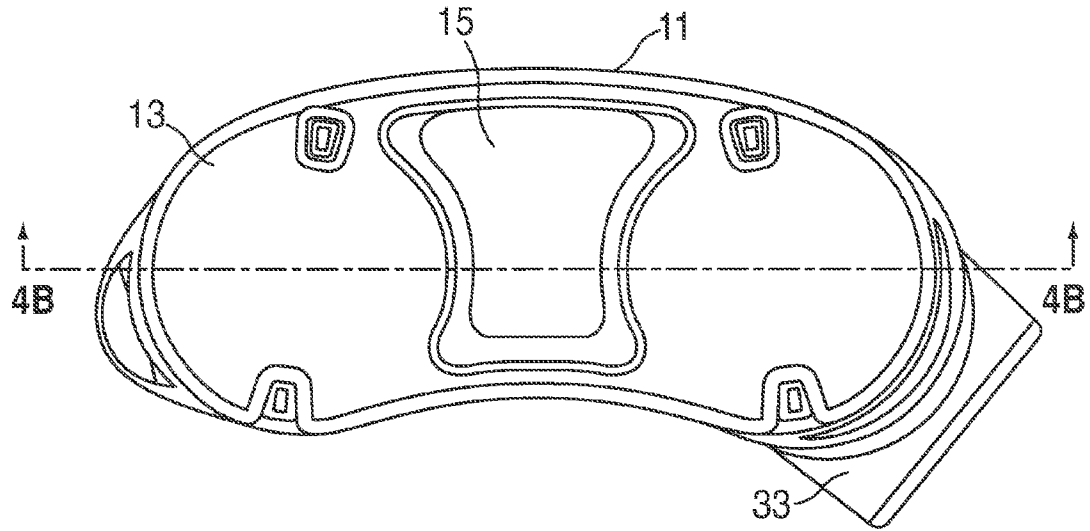

FIG. 4A

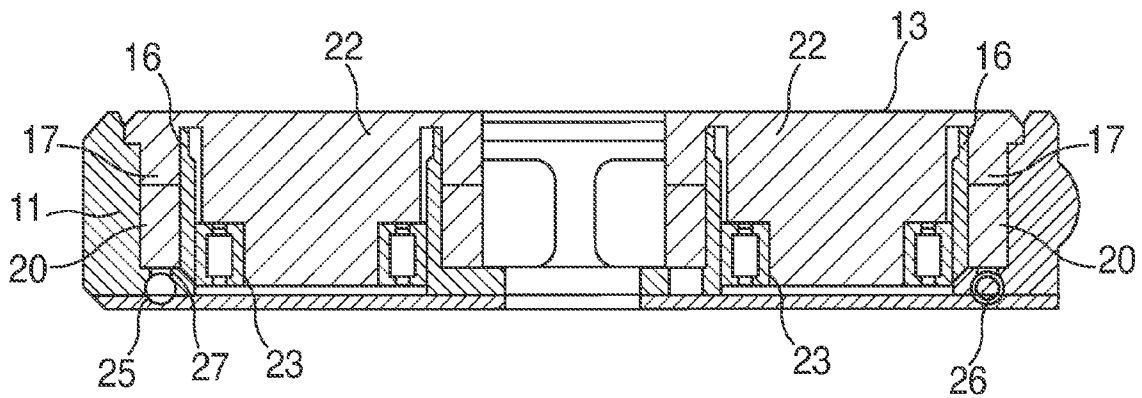

FIG. 4B

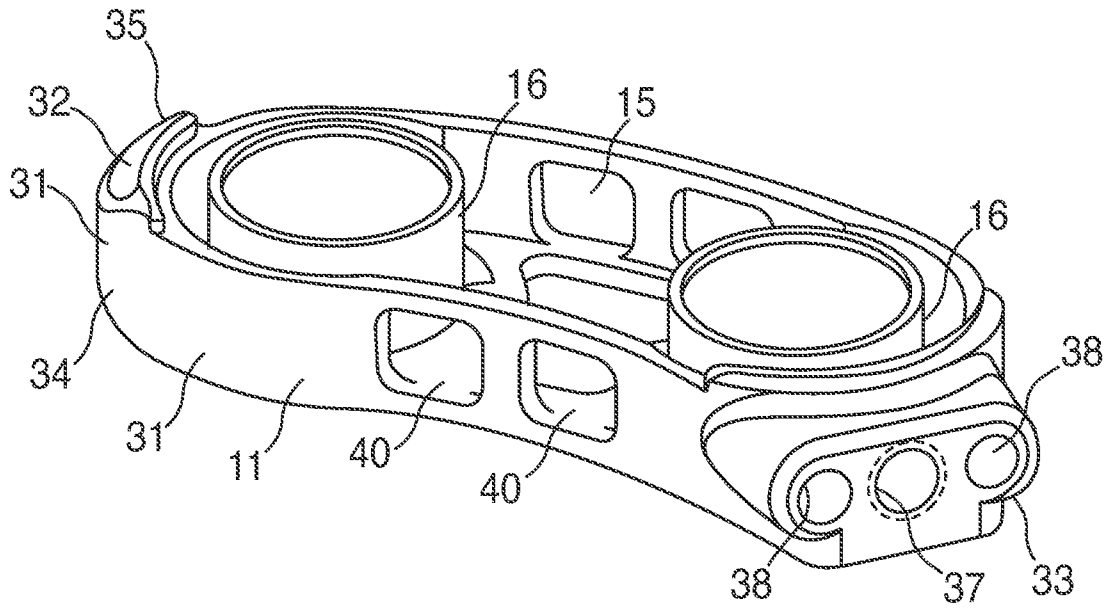

FIG. 5A

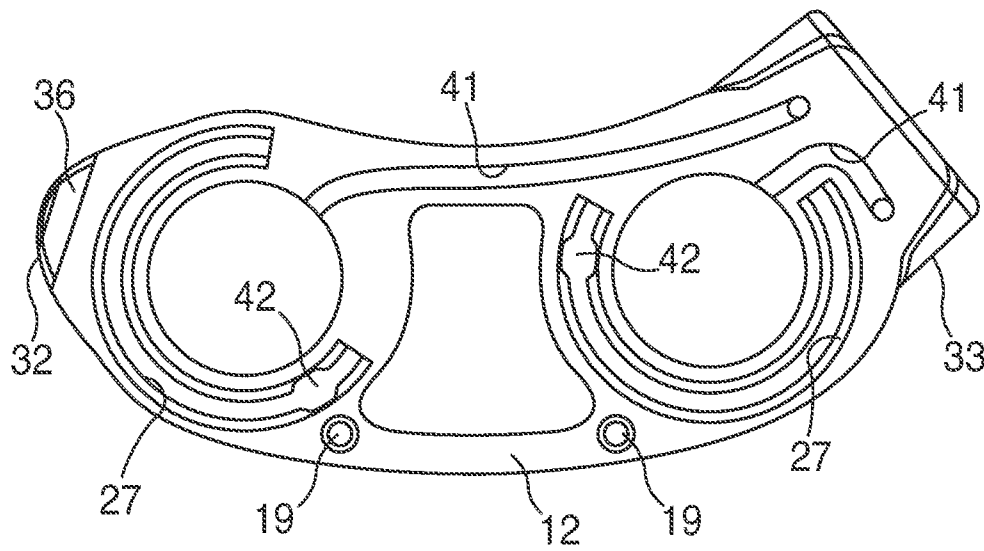

FIG. 5B

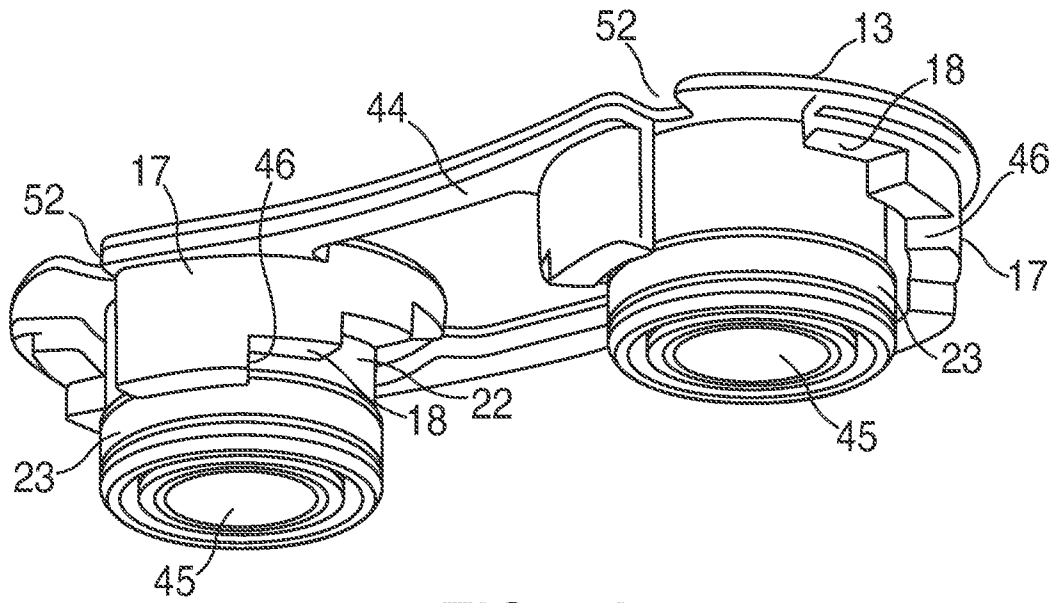

FIG. 6A

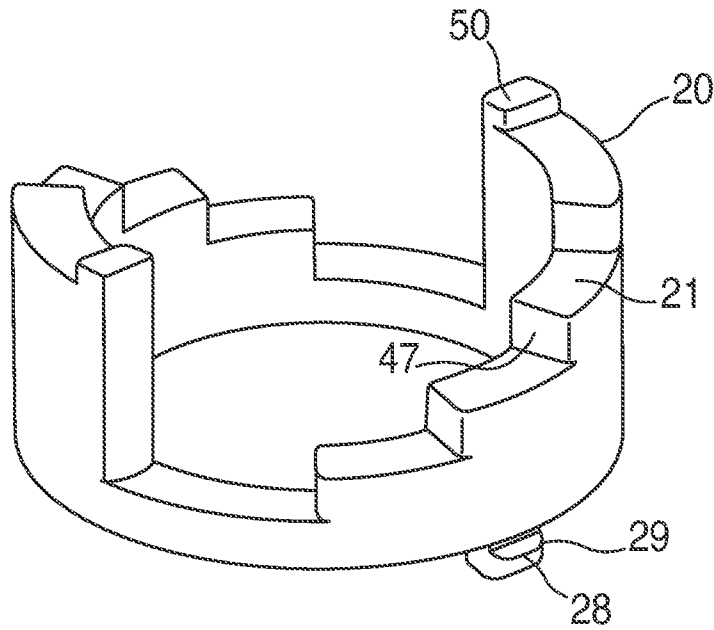

FIG. 6B

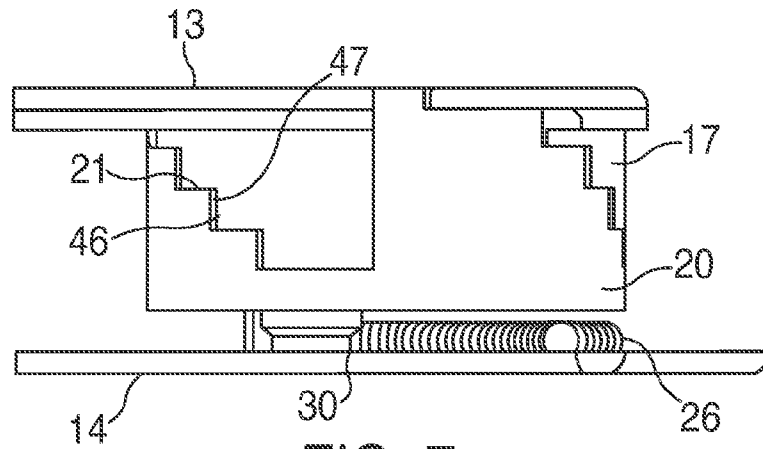

FIG. 7

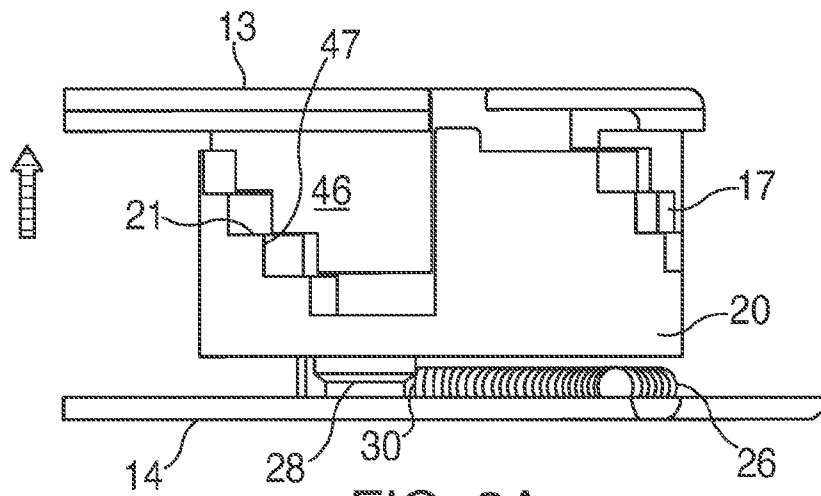

FIG. 8A

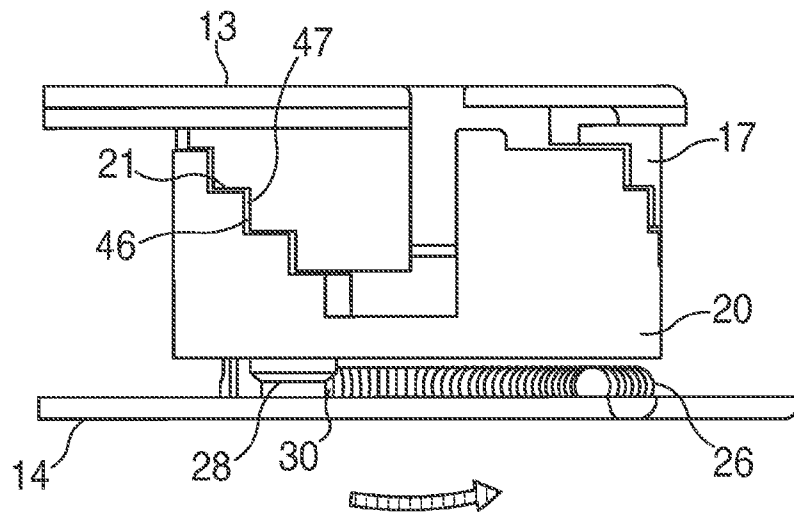

FIG. 8B

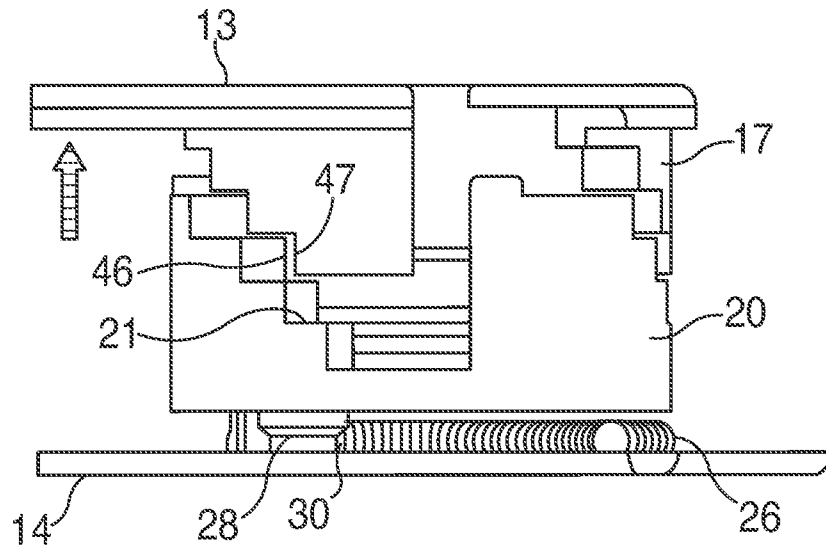

FIG. 9A

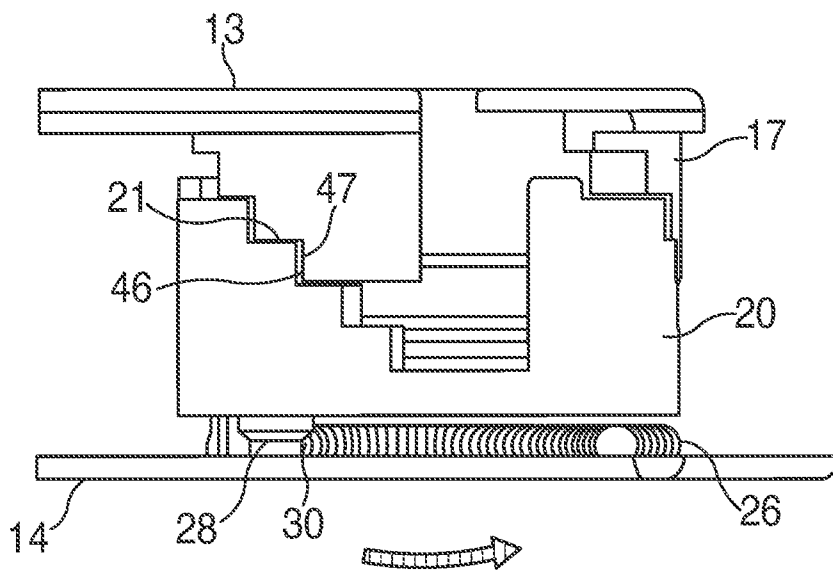

FIG. 9B

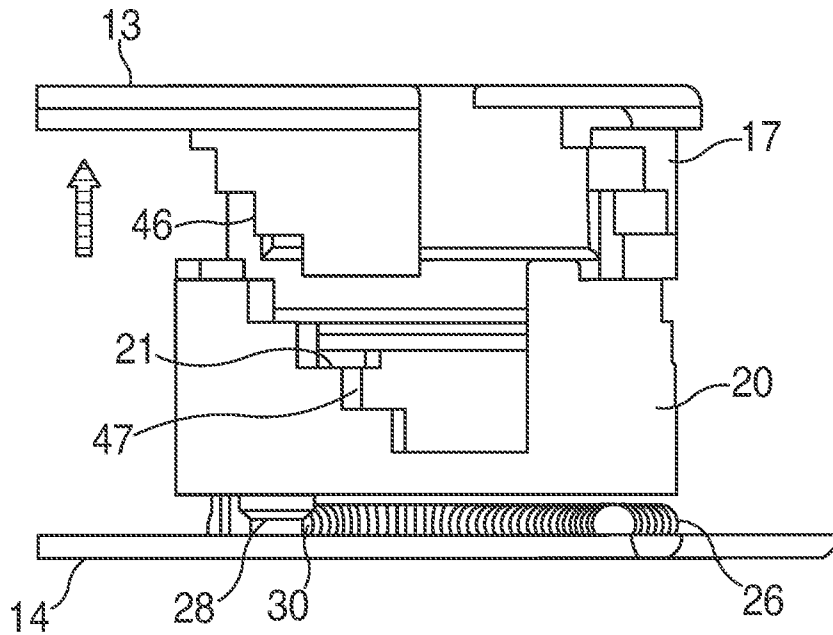

FIG. 10A

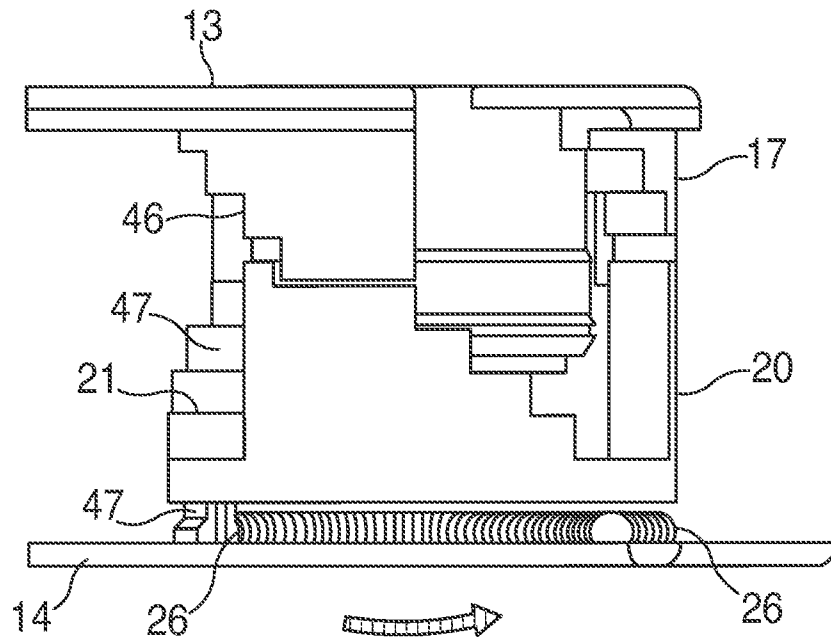

FIG. 10B

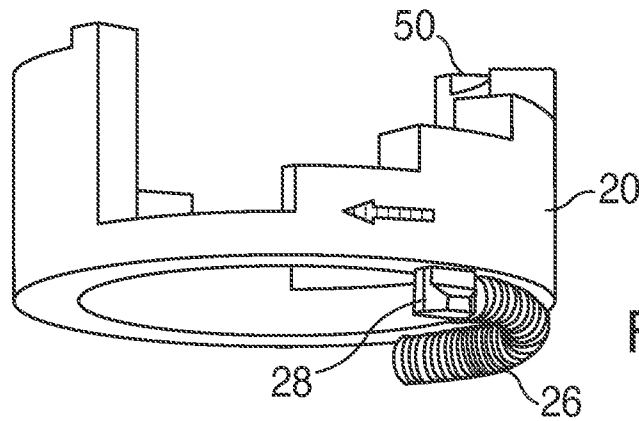

FIG. 11A

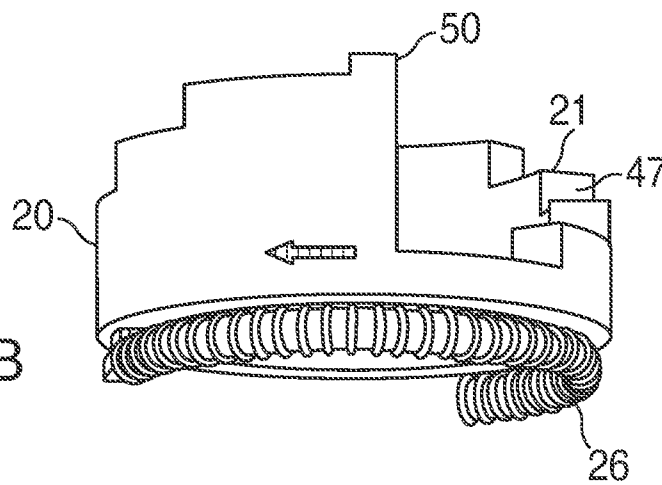

FIG. 11B

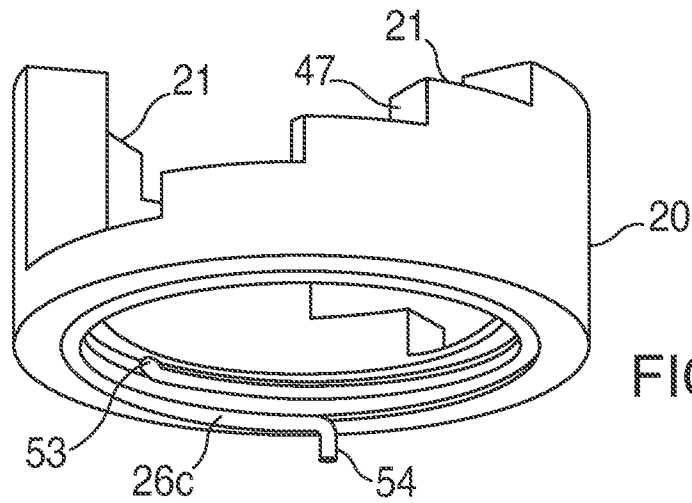

FIG. 11C

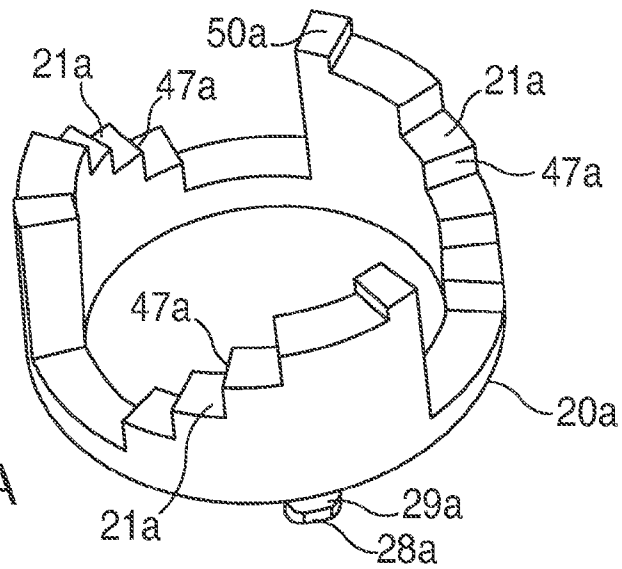

FIG. 12A

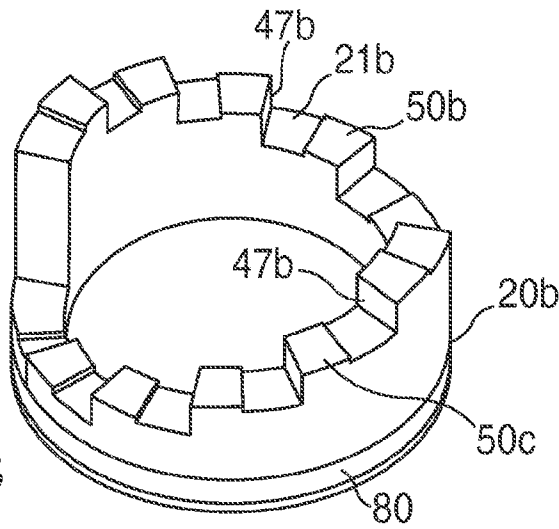

FIG. 12B

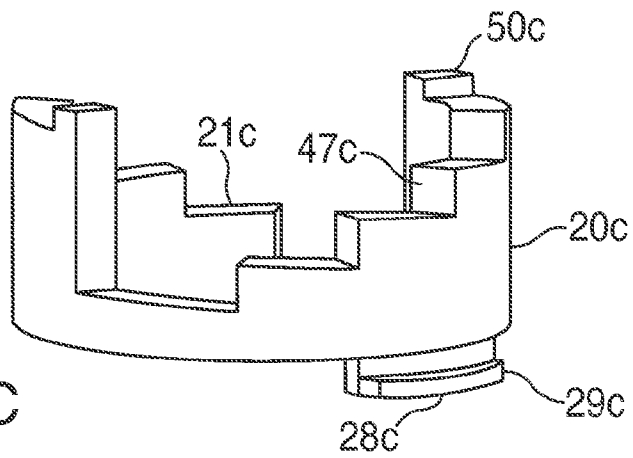

FIG. 12C

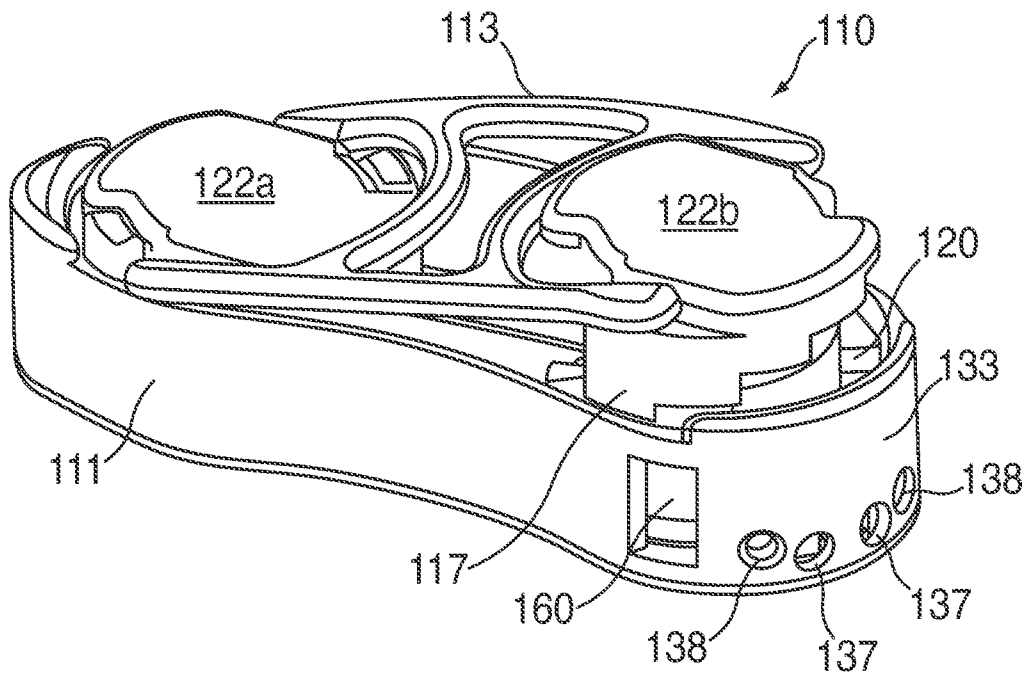

FIG. 13A

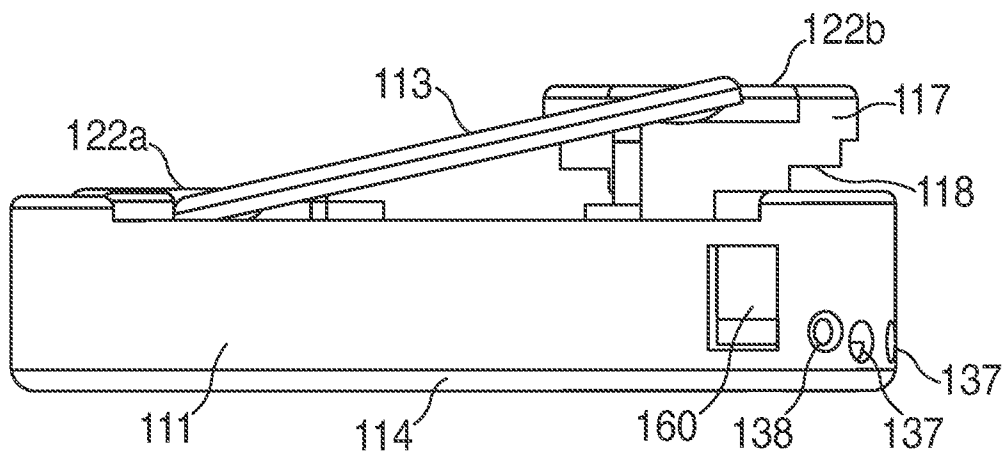

FIG. 13B

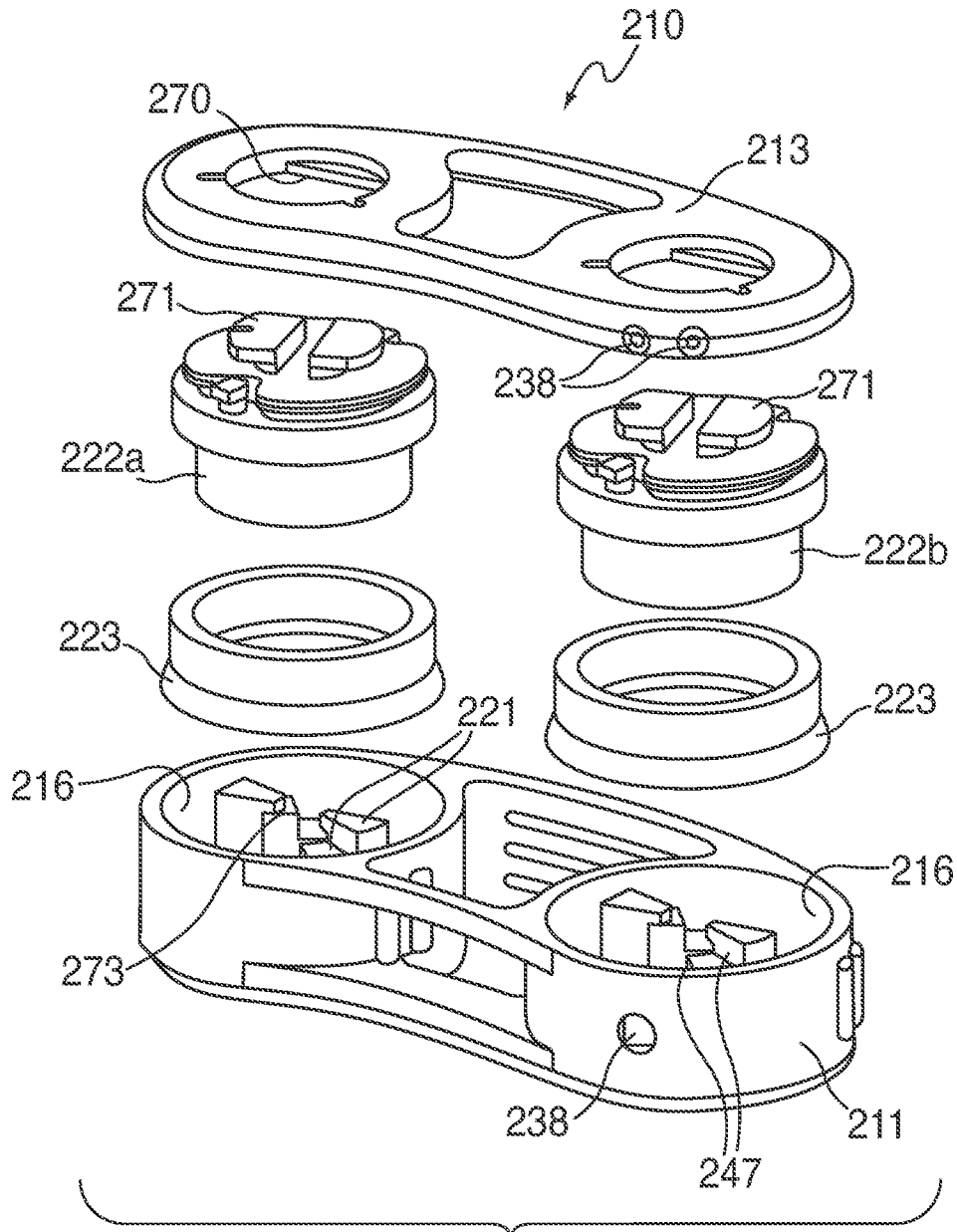

FIG. 14A

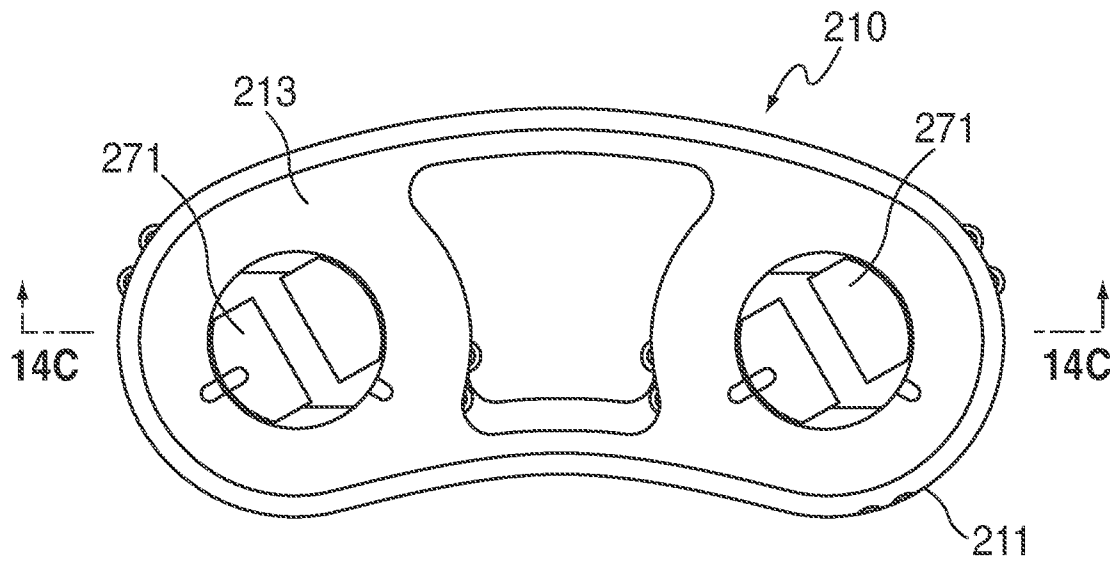

FIG. 14B

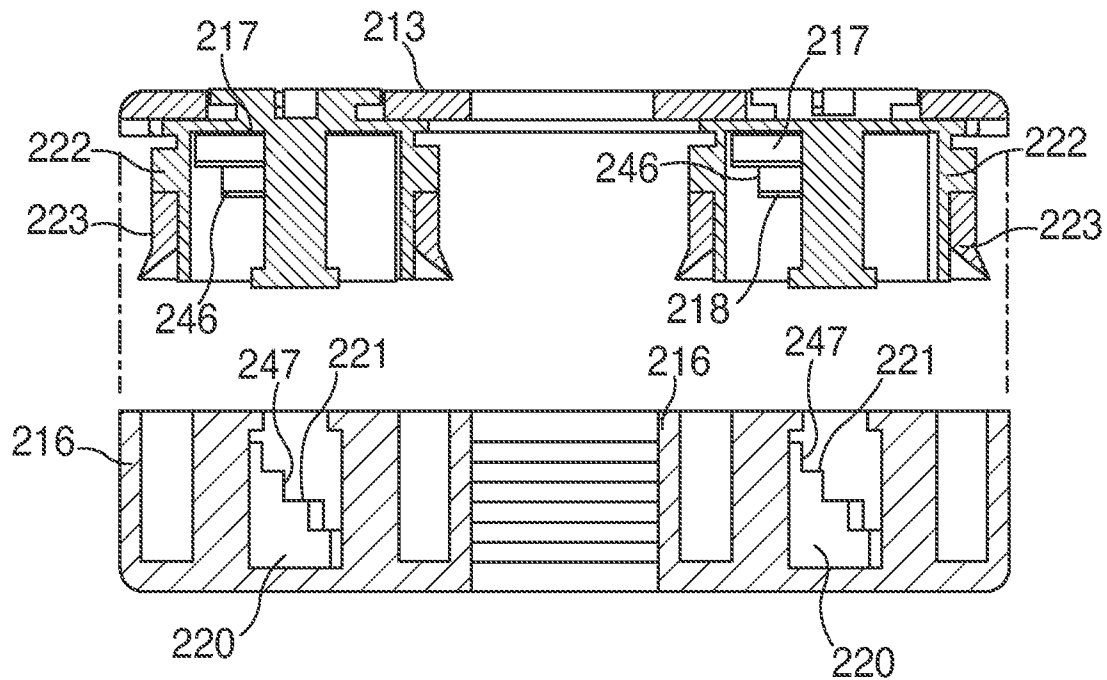

FIG. 14C

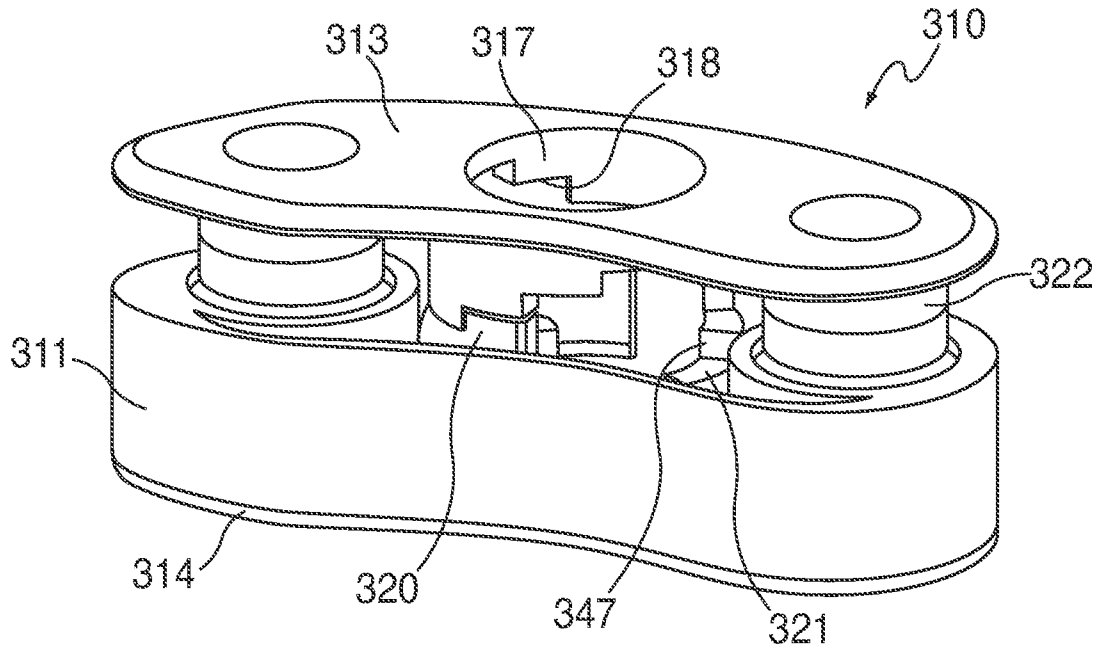

FIG. 15

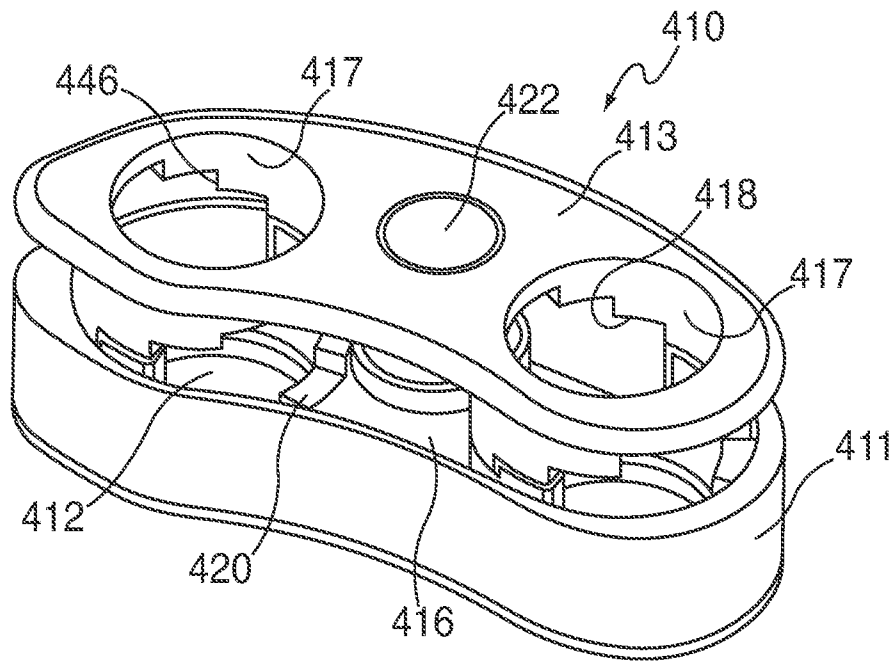

FIG. 16

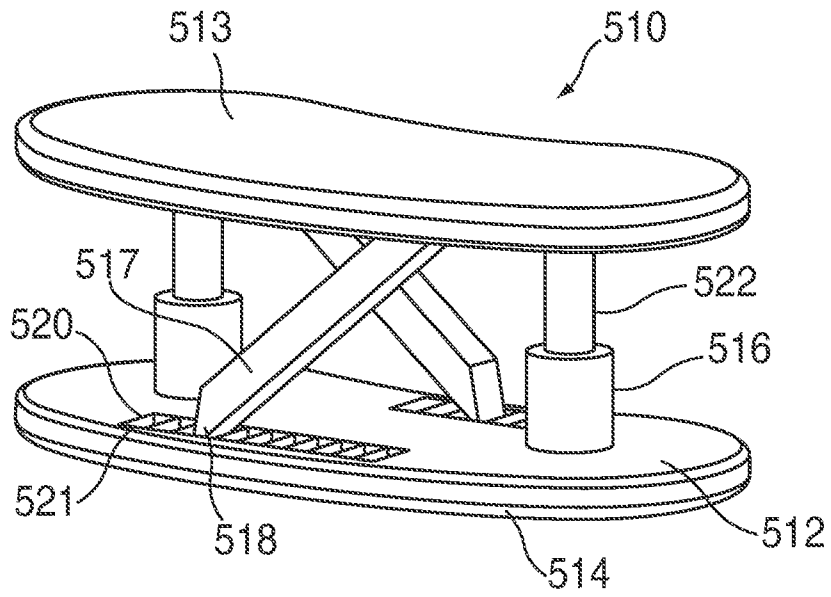

FIG. 17

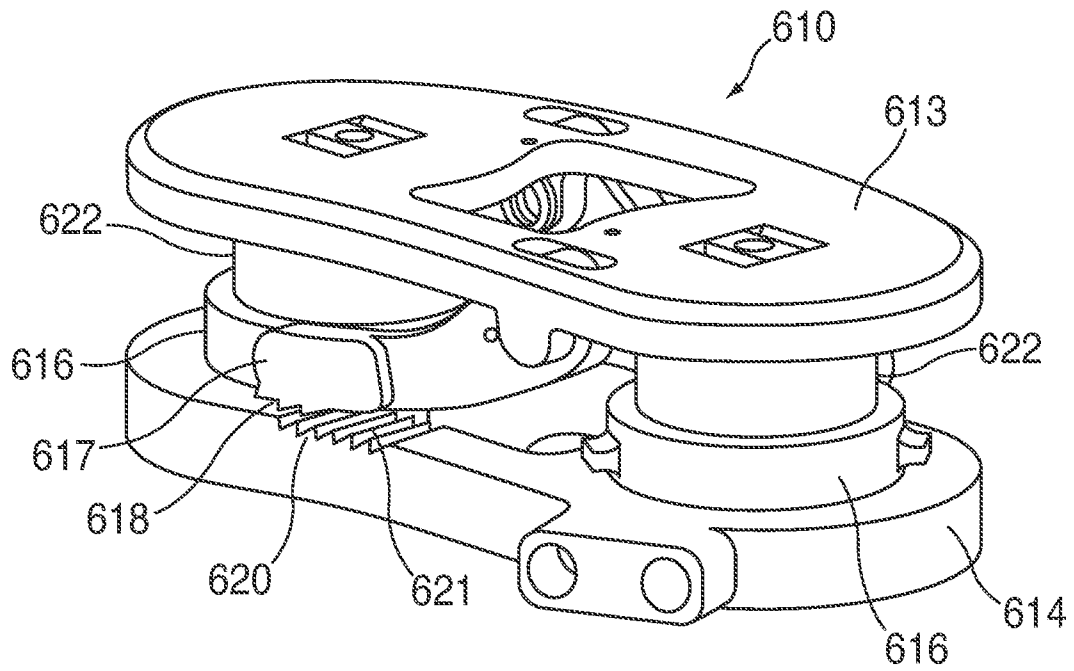

FIG. 18

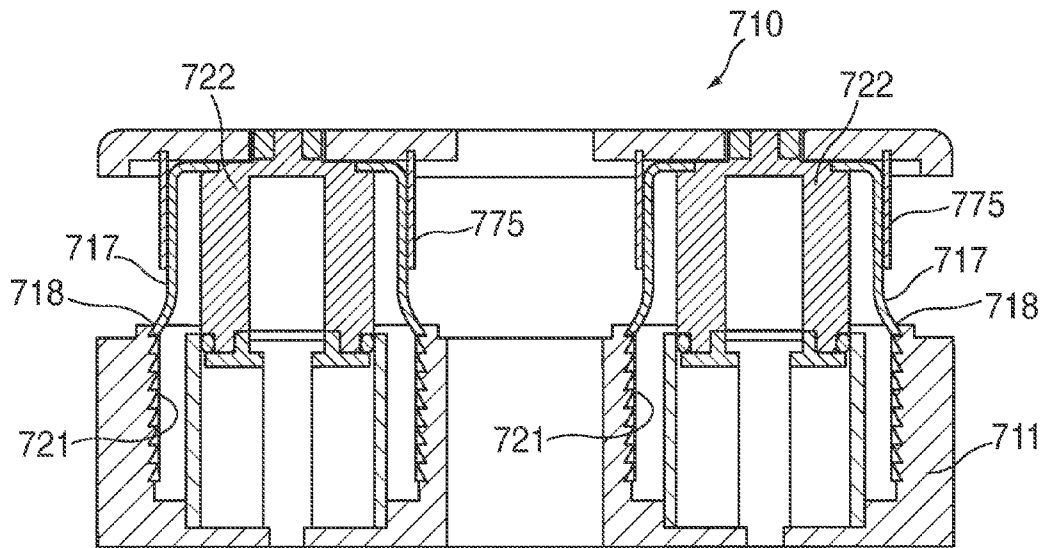

FIG. 19

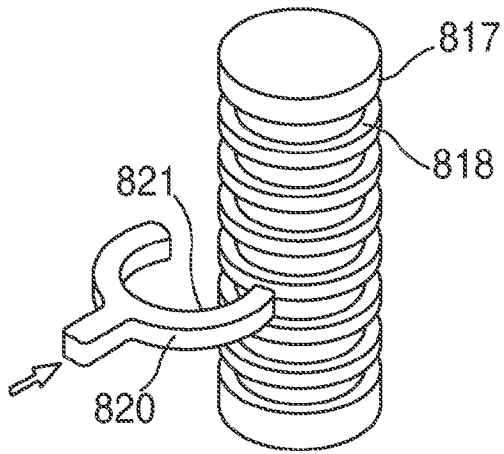

FIG. 20A

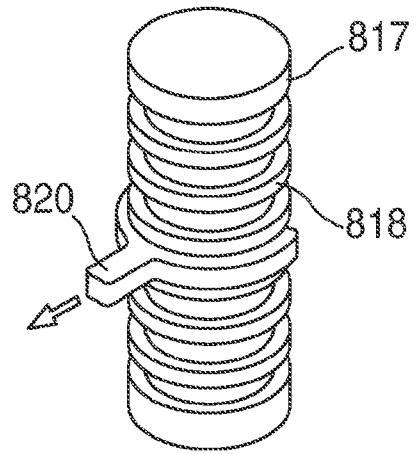

FIG. 20B

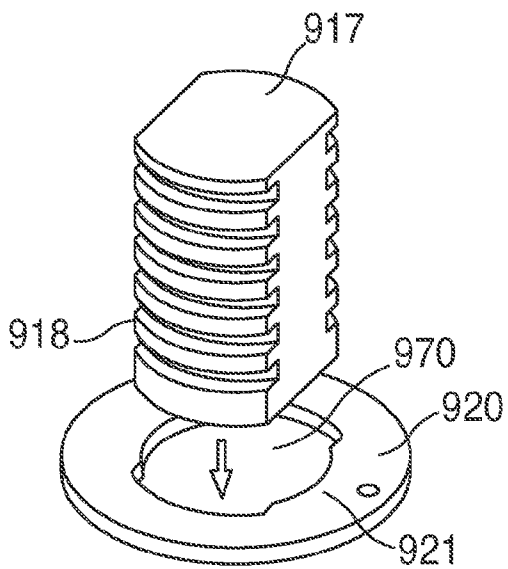

FIG. 21A

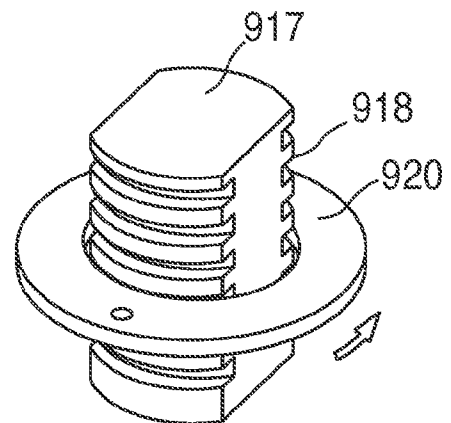

FIG. 21B

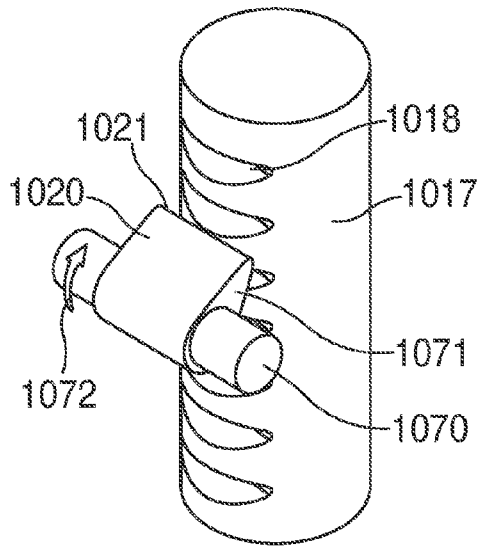

FIG. 22

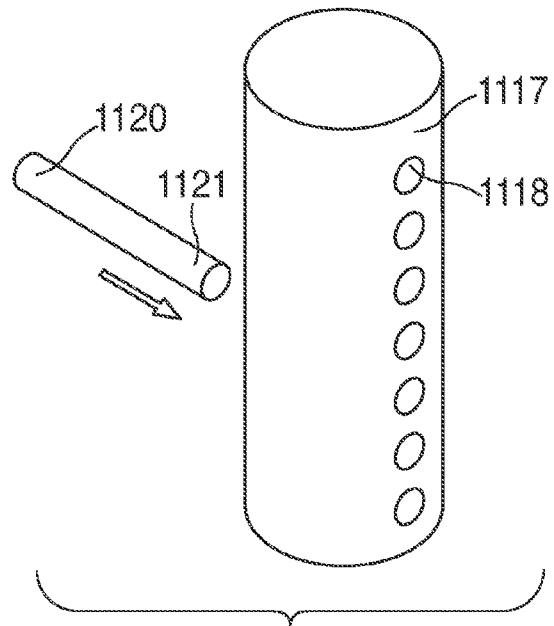

FIG. 23

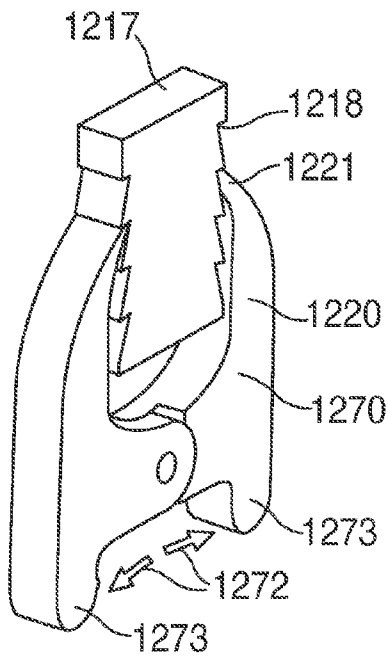

FIG. 24

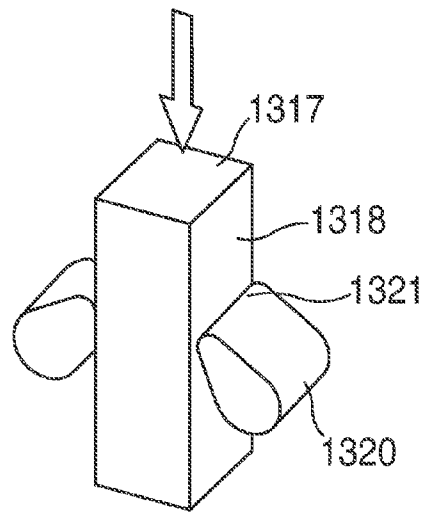

FIG. 25

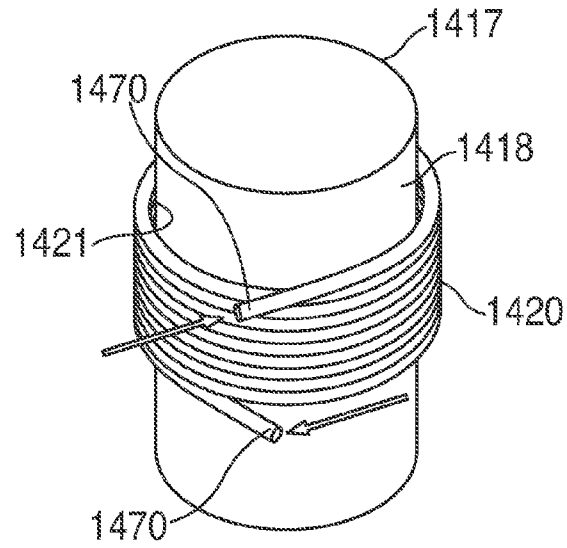

FIG. 26

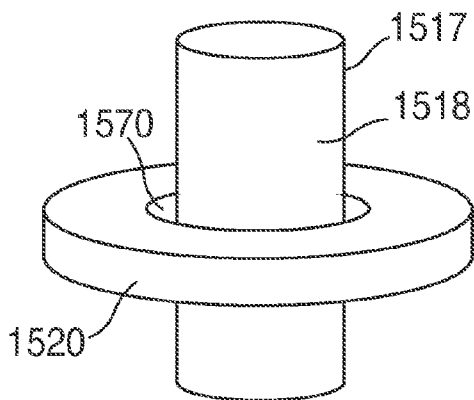

FIG. 27A

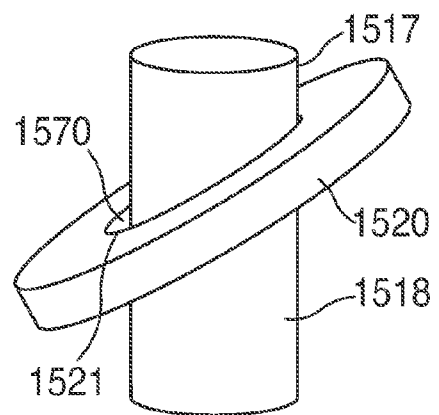
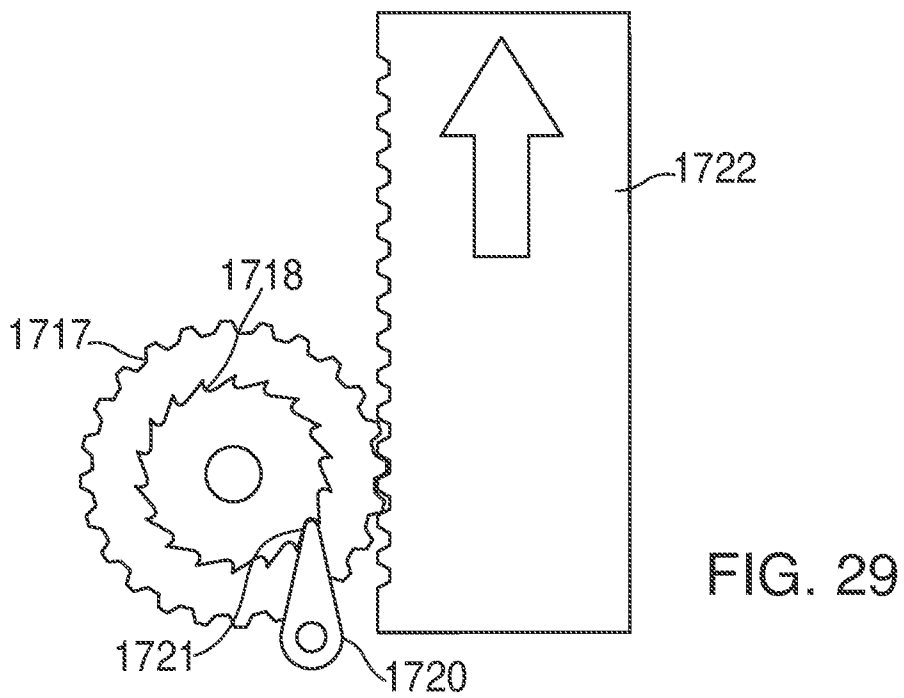
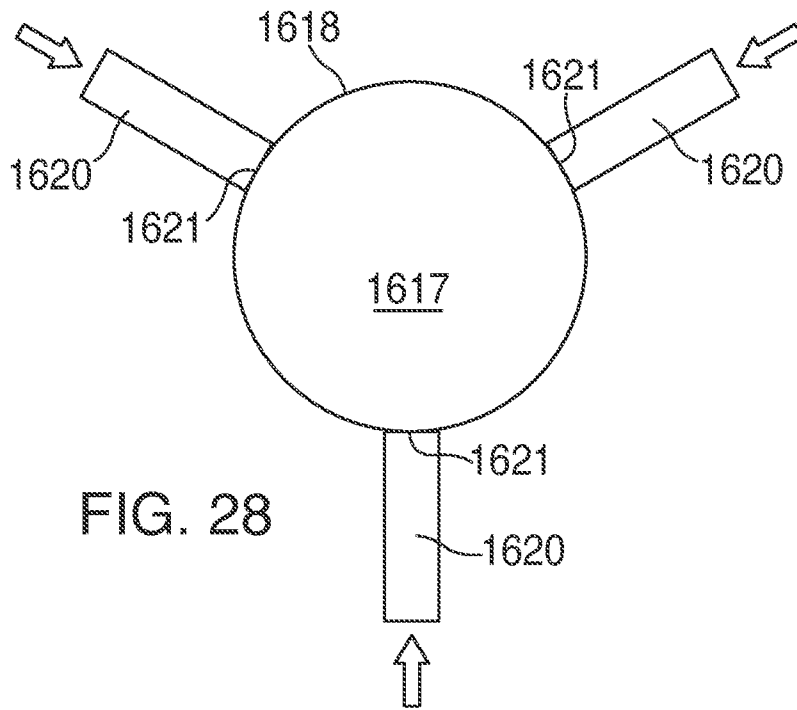

FIG. 27B



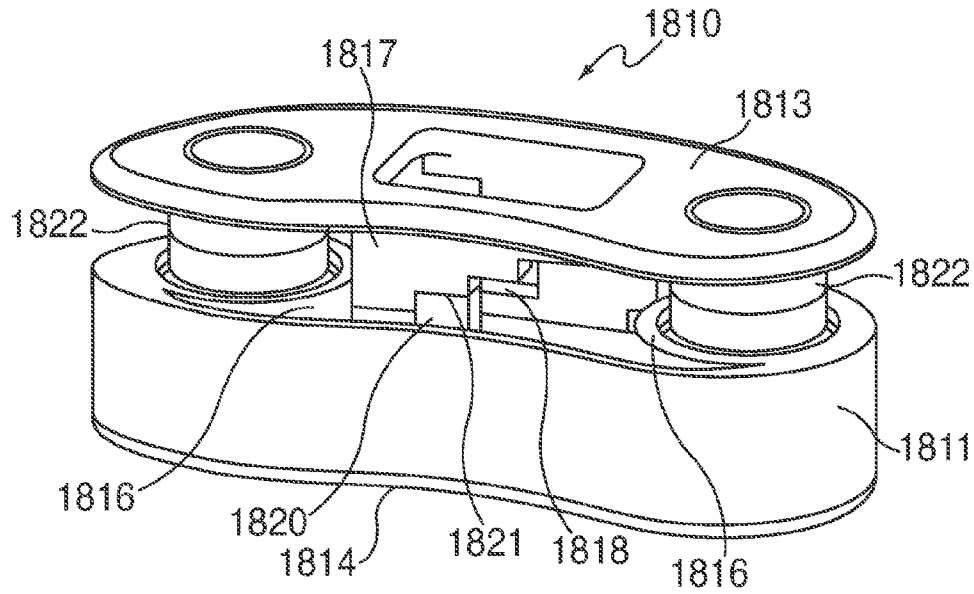

FIG. 30

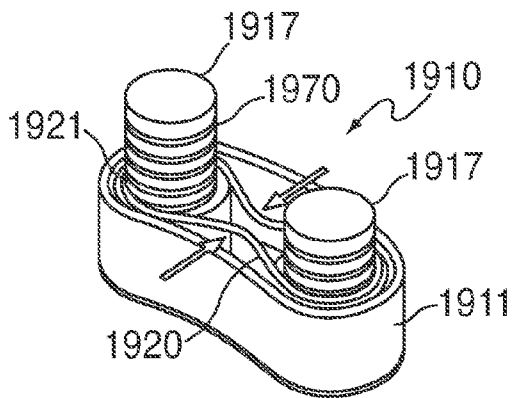

FIG. 31A

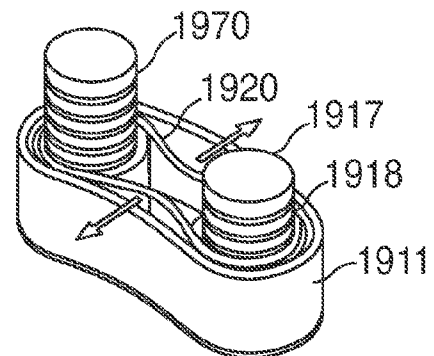

FIG. 31B

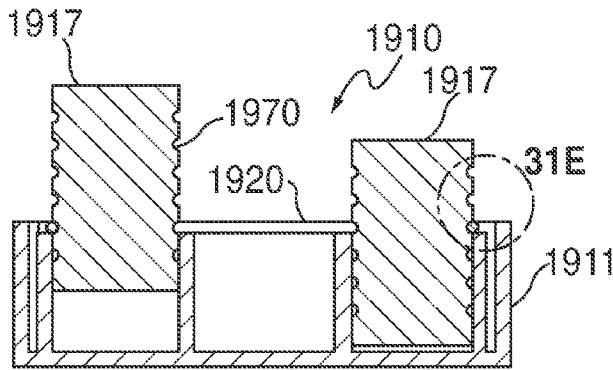

FIG. 31C

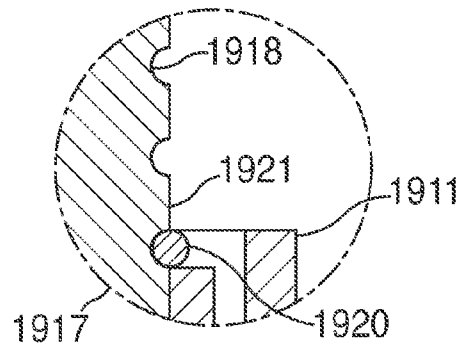

FIG. 31E

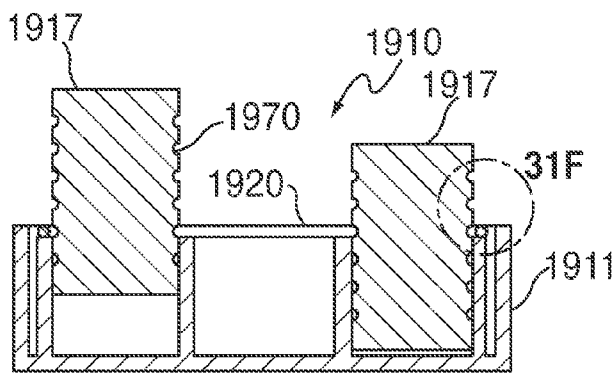

FIG. 31D

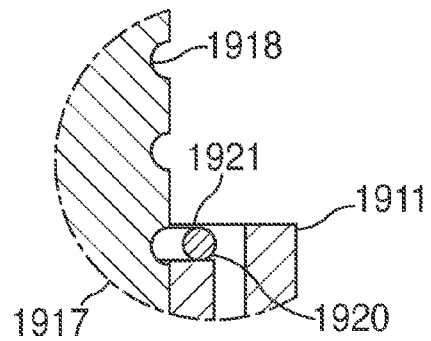

FIG. 31F

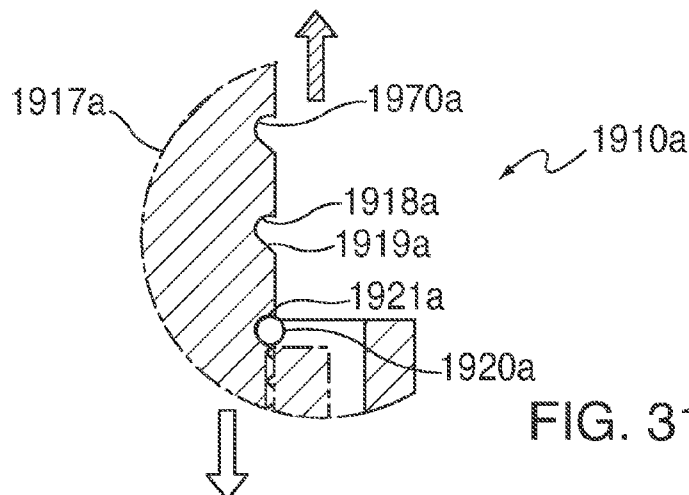

FIG. 31G

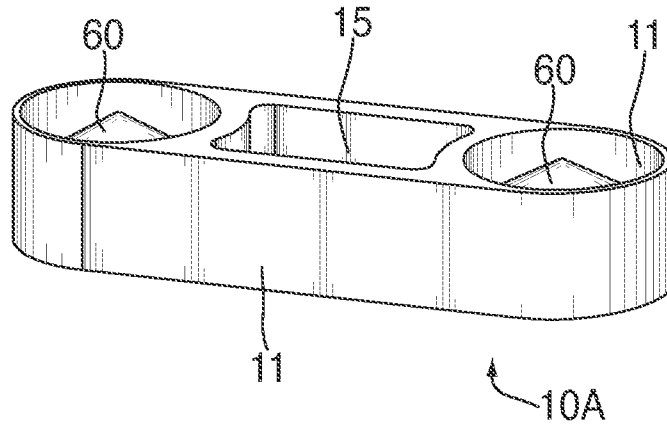

FIG. 32A

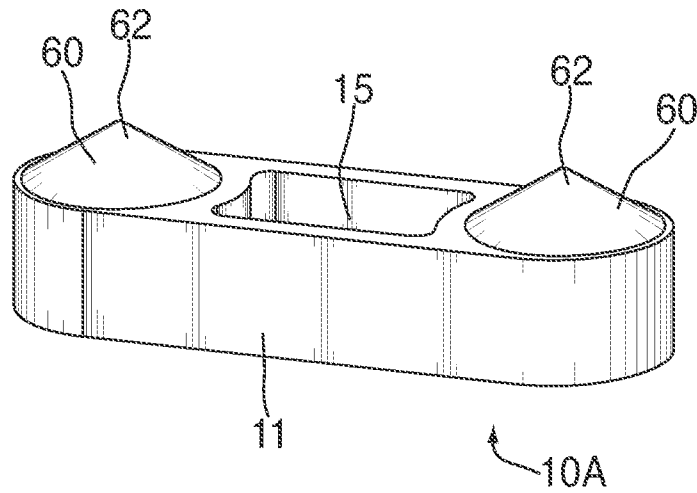

FIG. 32B

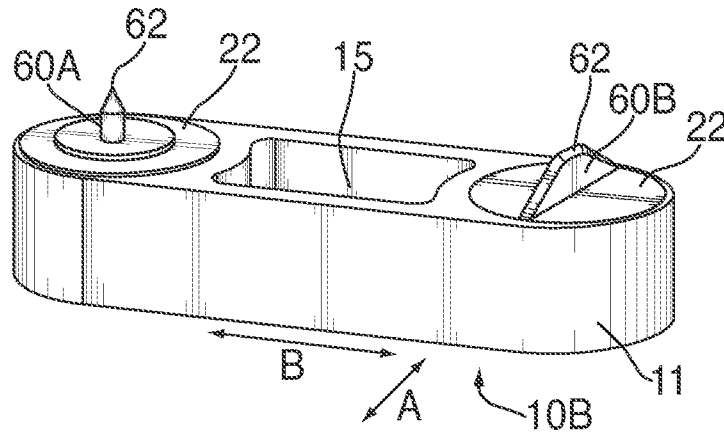

FIG. 33A

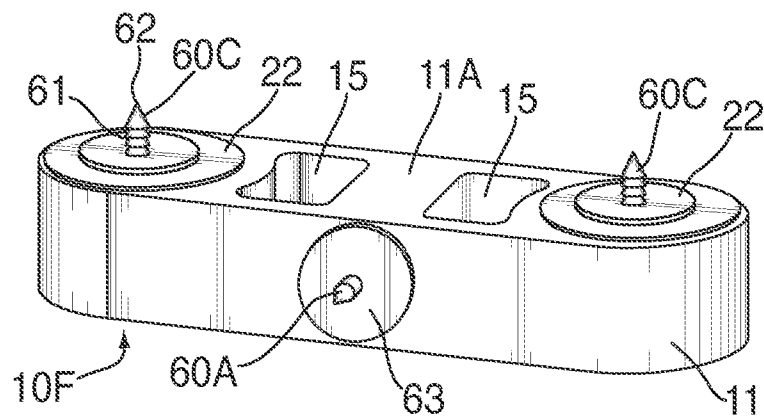

FIG. 33B

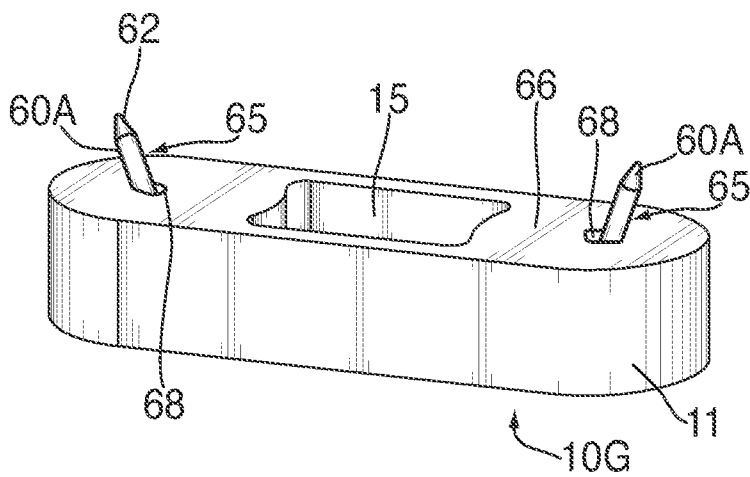

FIG. 33C

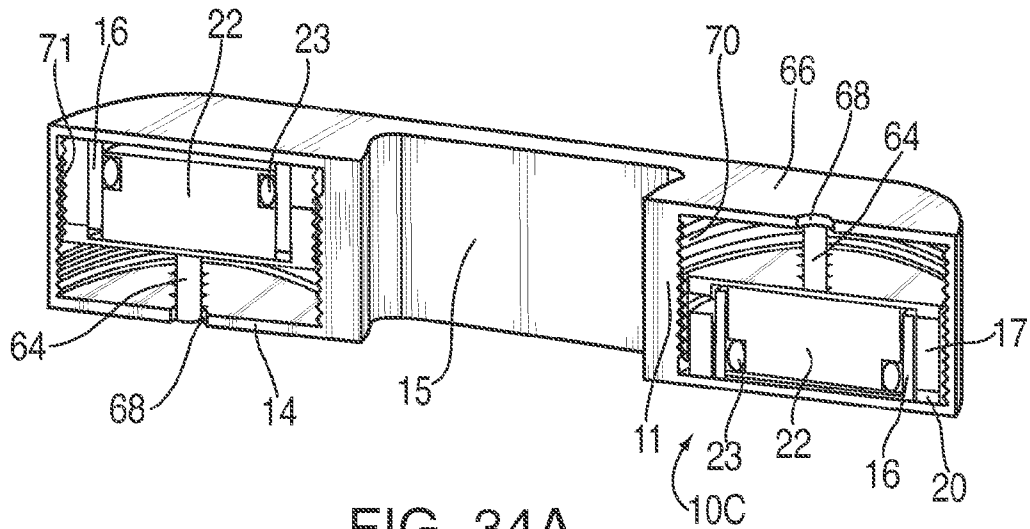

FIG. 34A

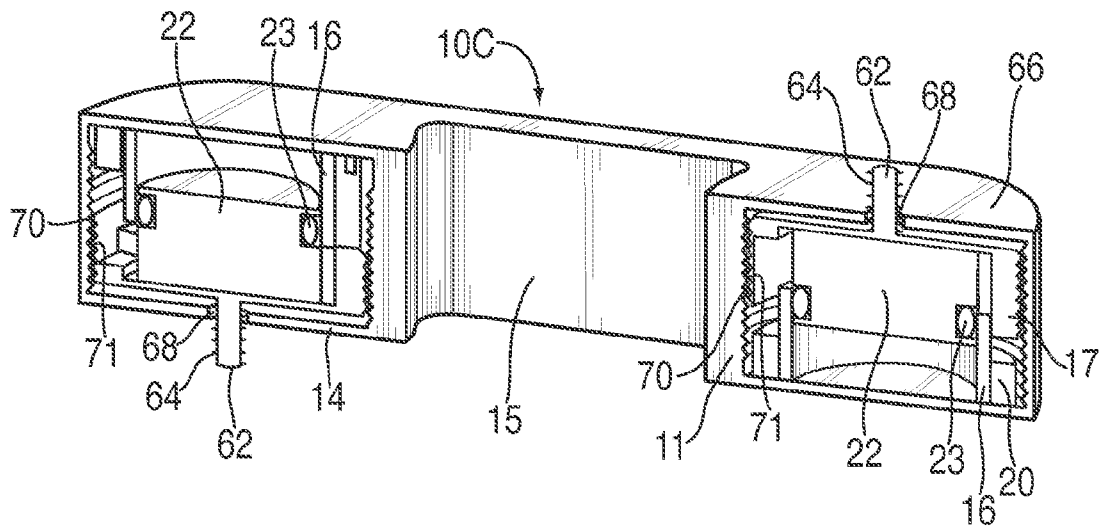

FIG. 34B

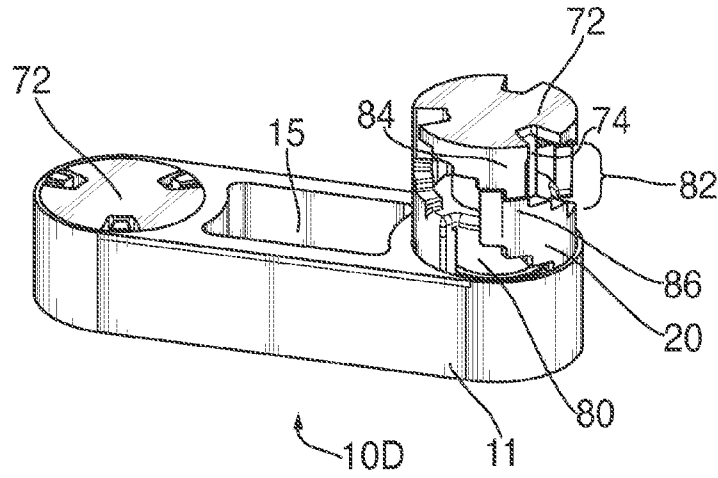

FIG. 35A

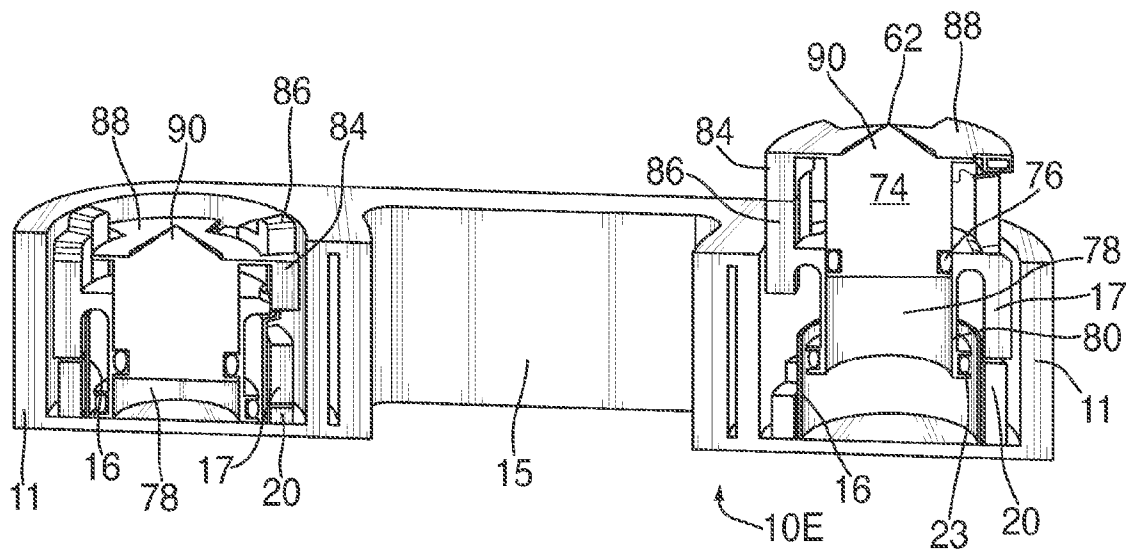

FIG. 35B

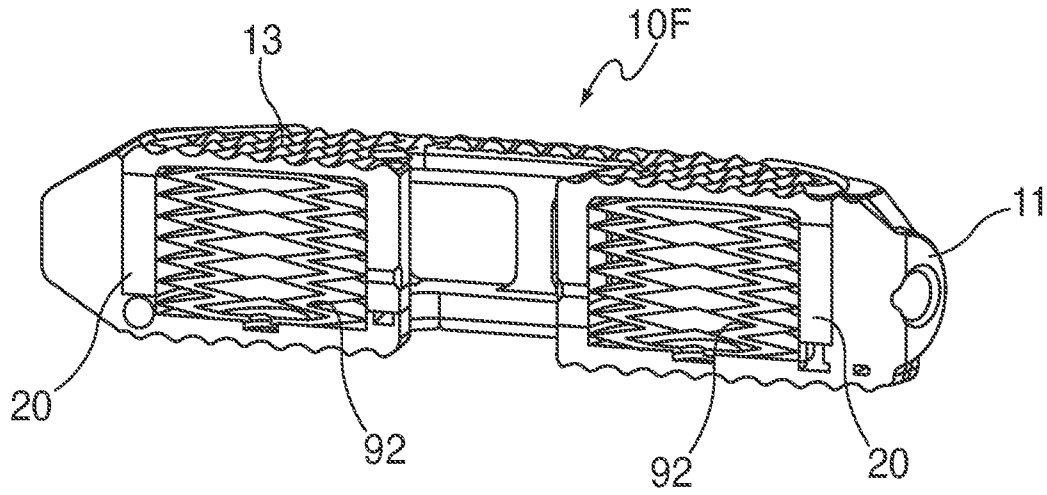

FIG. 36A

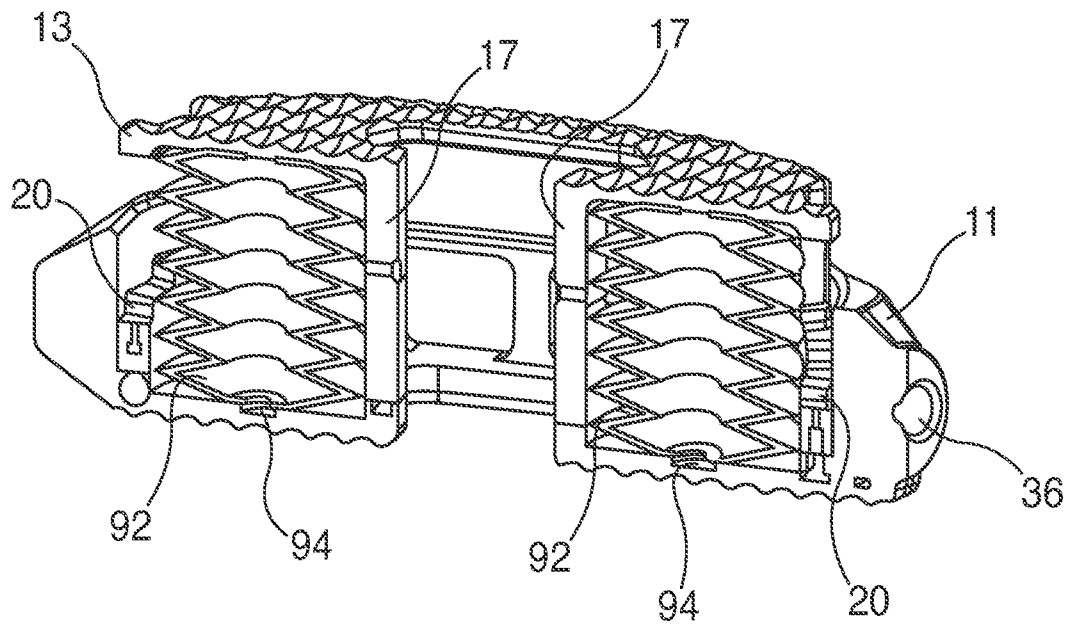

FIG. 36B

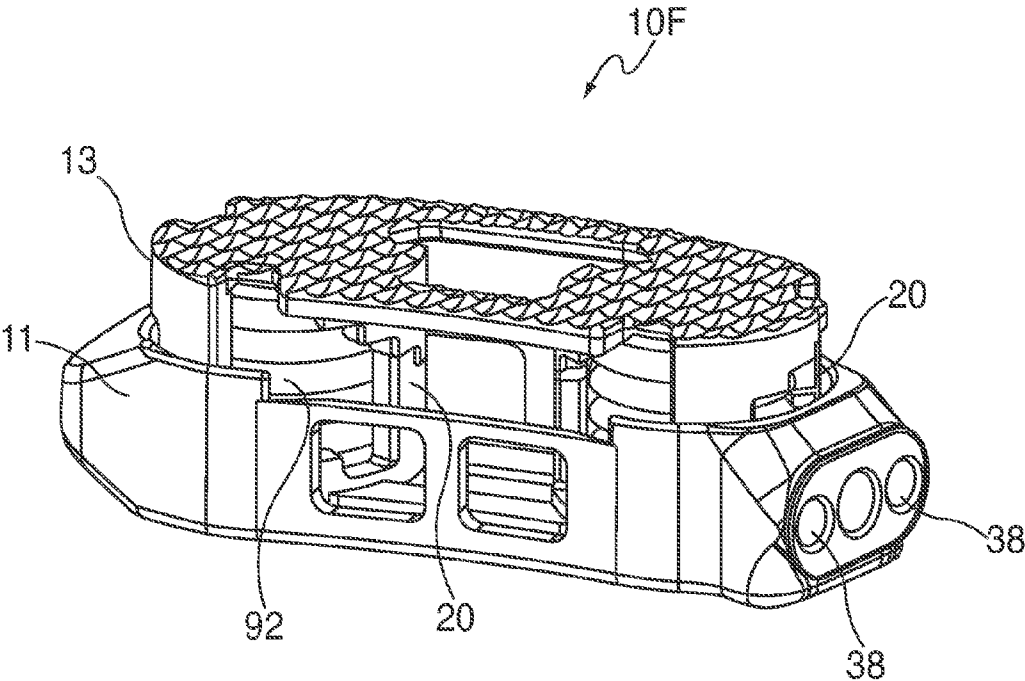

FIG. 36C

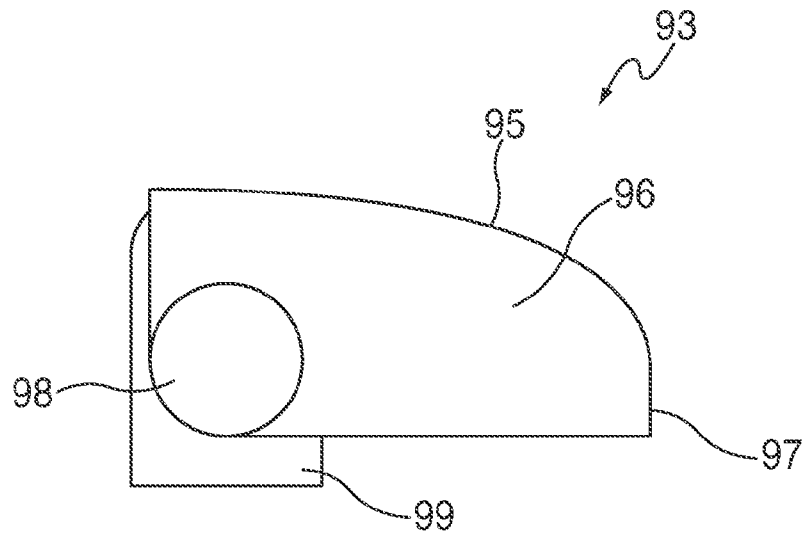

FIG. 37A

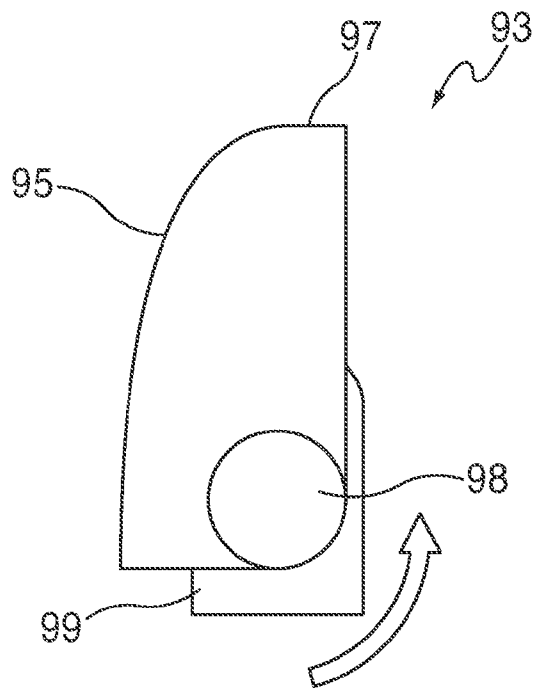

FIG. 37B

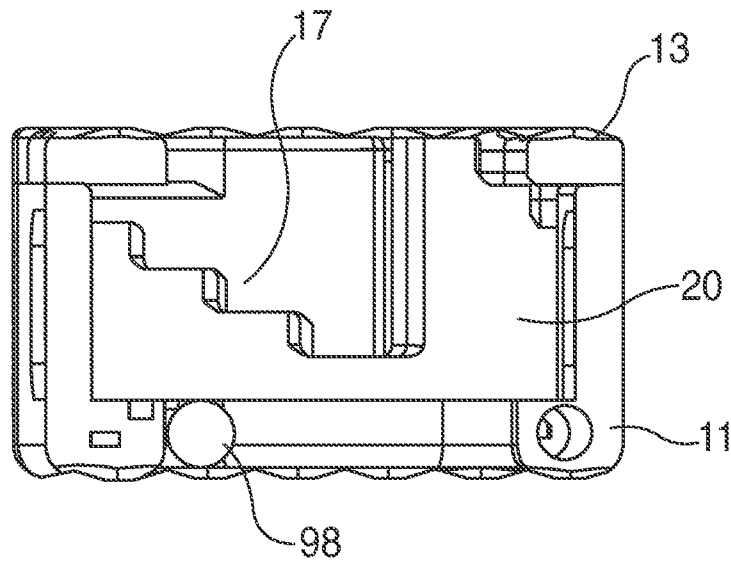

FIG. 38A

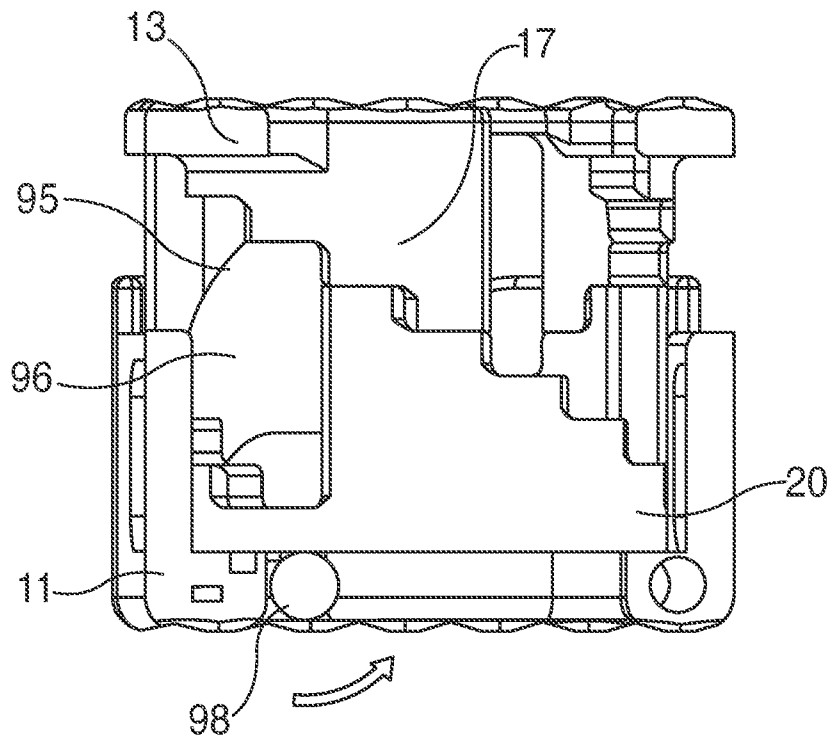

FIG. 38B

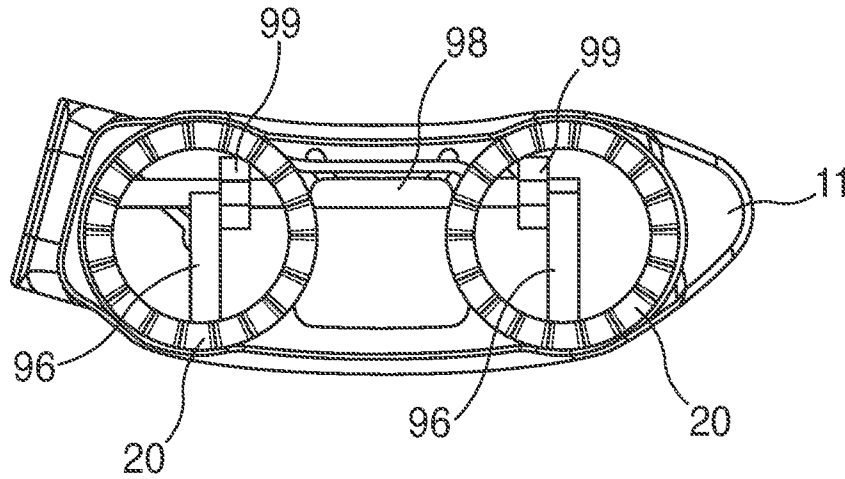

FIG. 39A

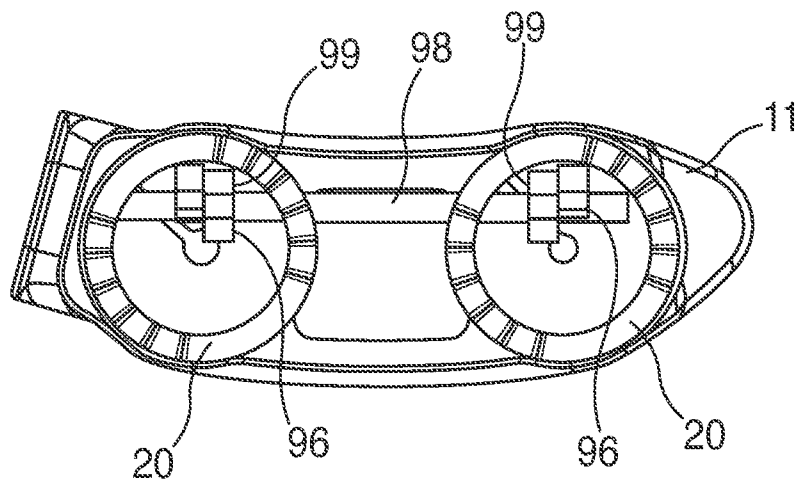

FIG. 39B

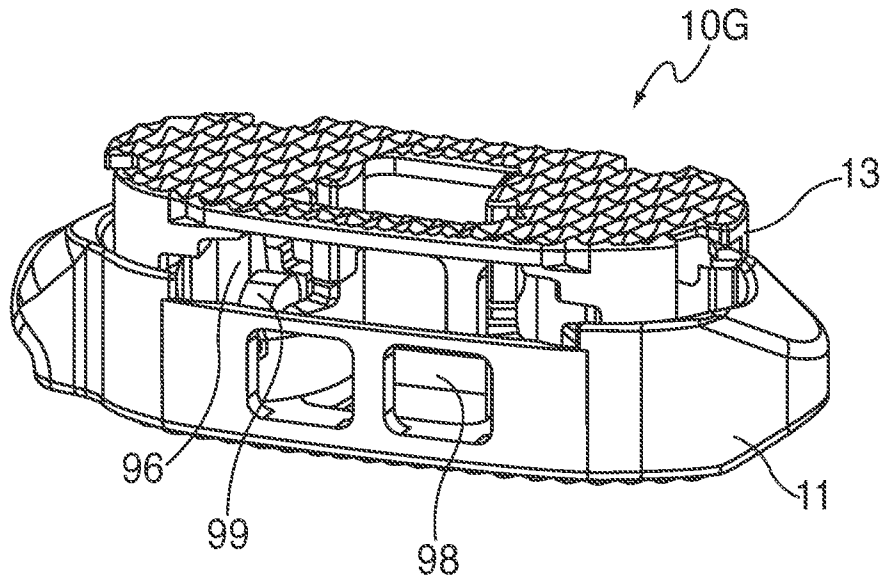

FIG. 40

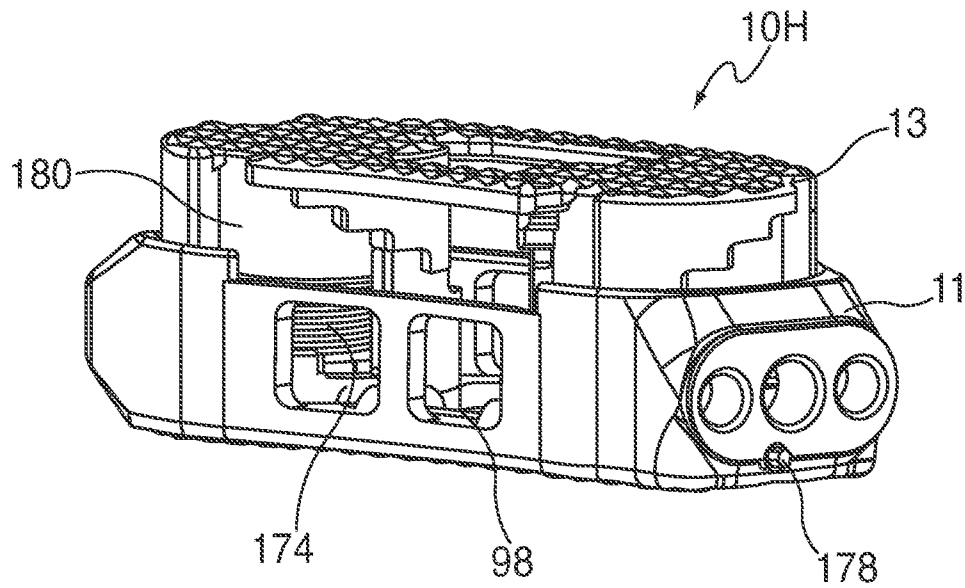

FIG. 41

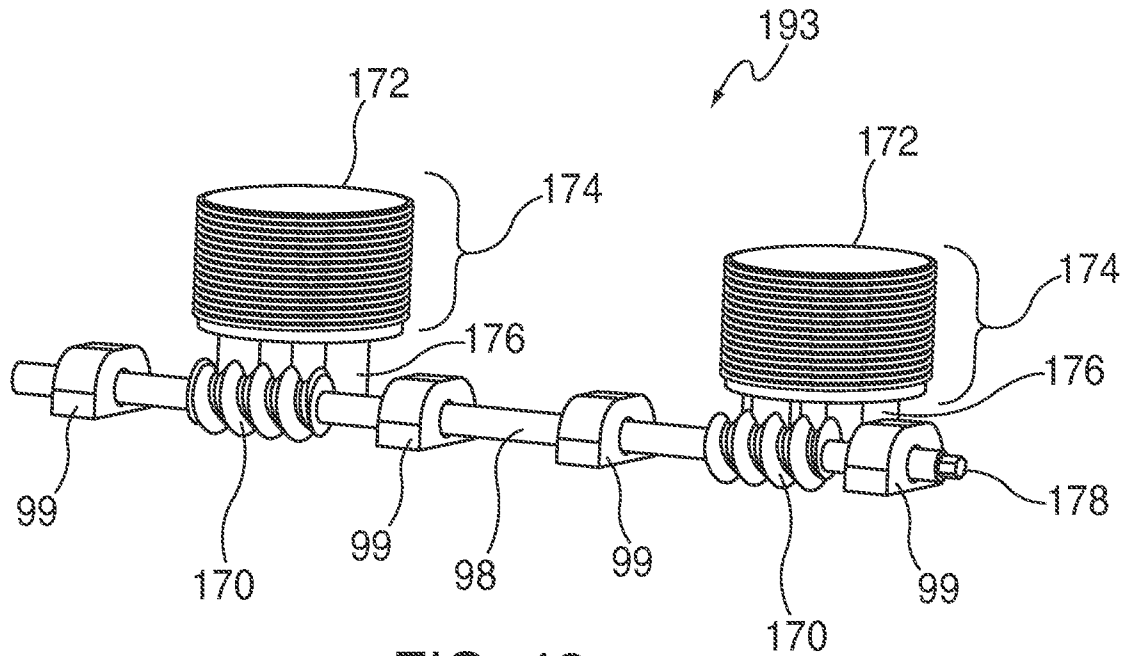

FIG. 42

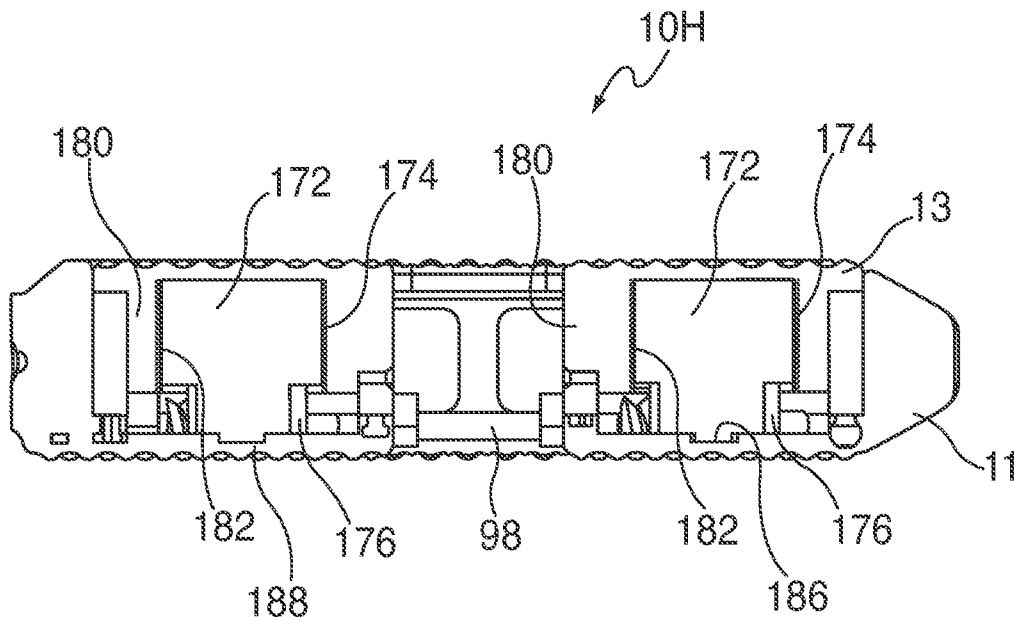

FIG. 43A

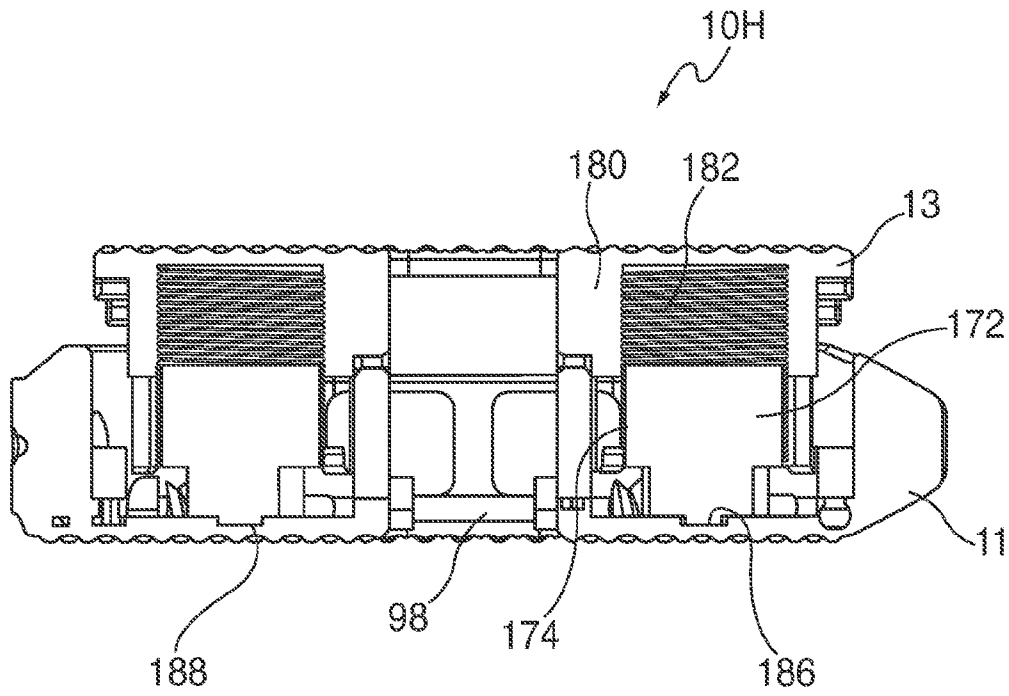
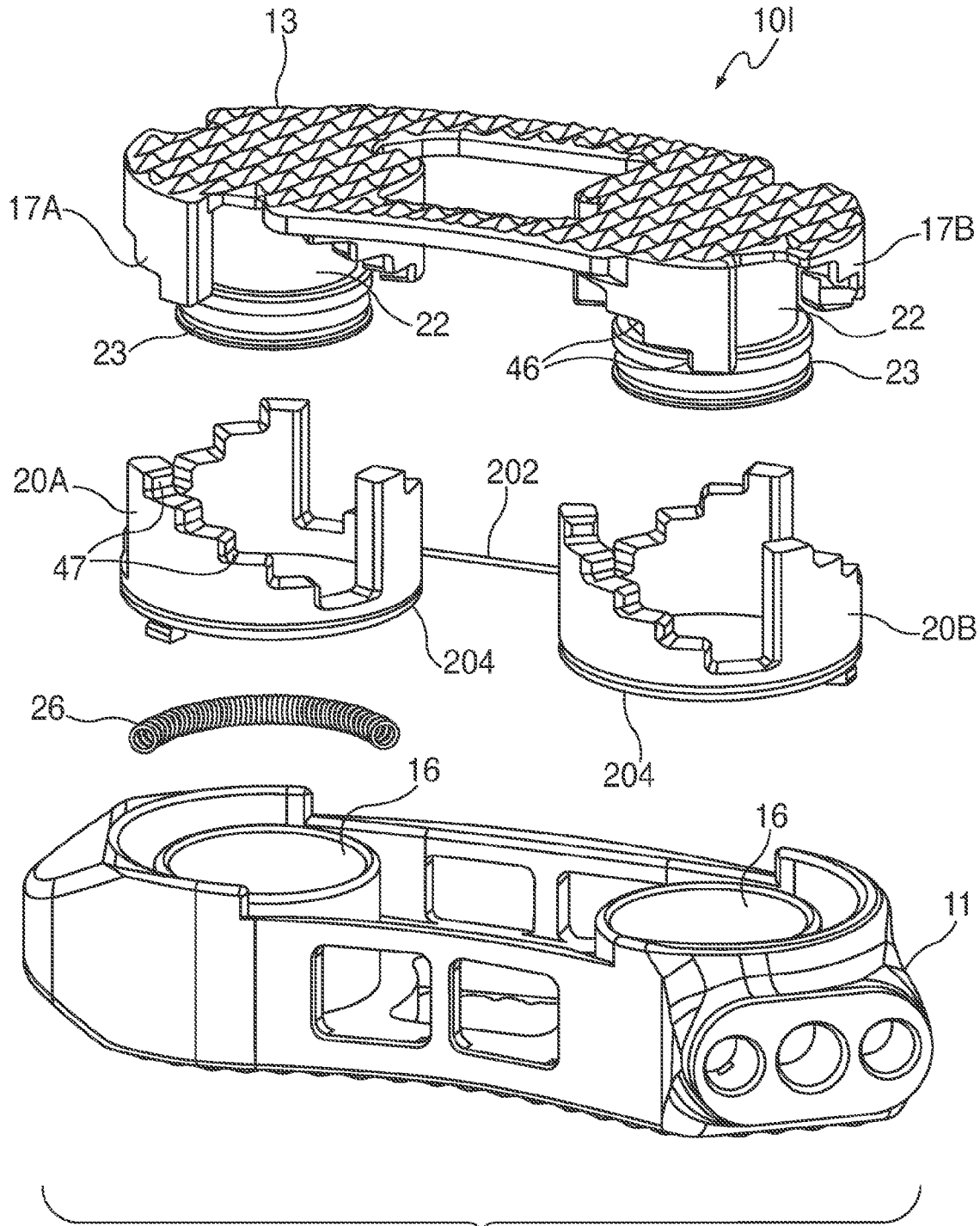

FIG. 43B



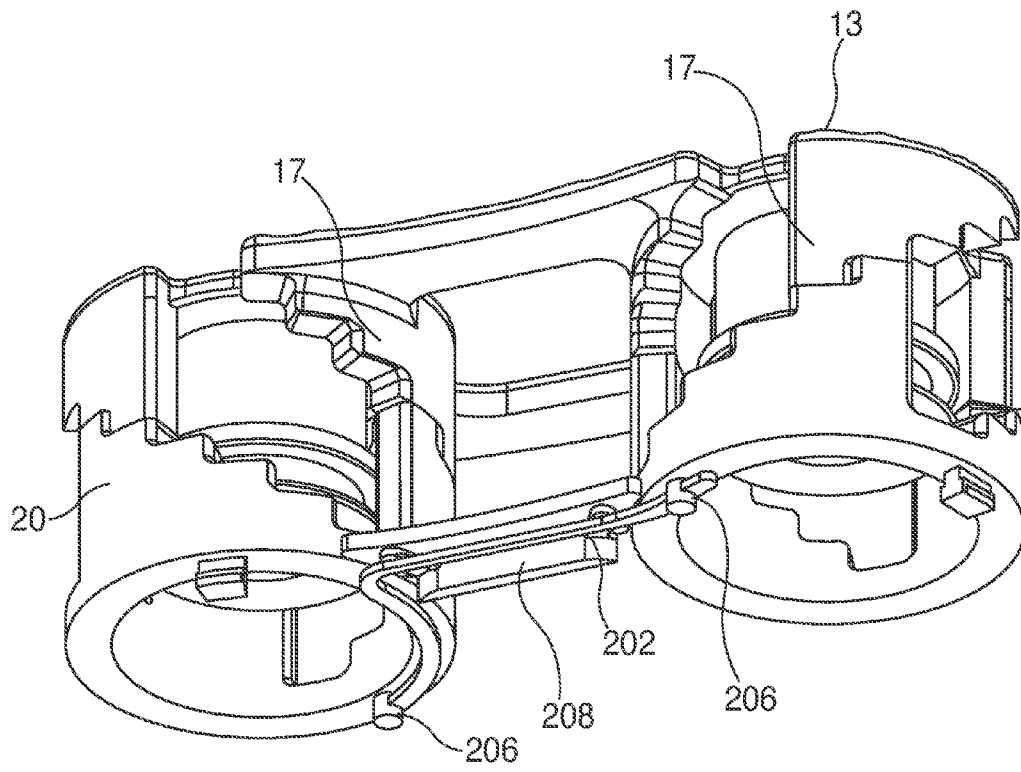

FIG. 45A

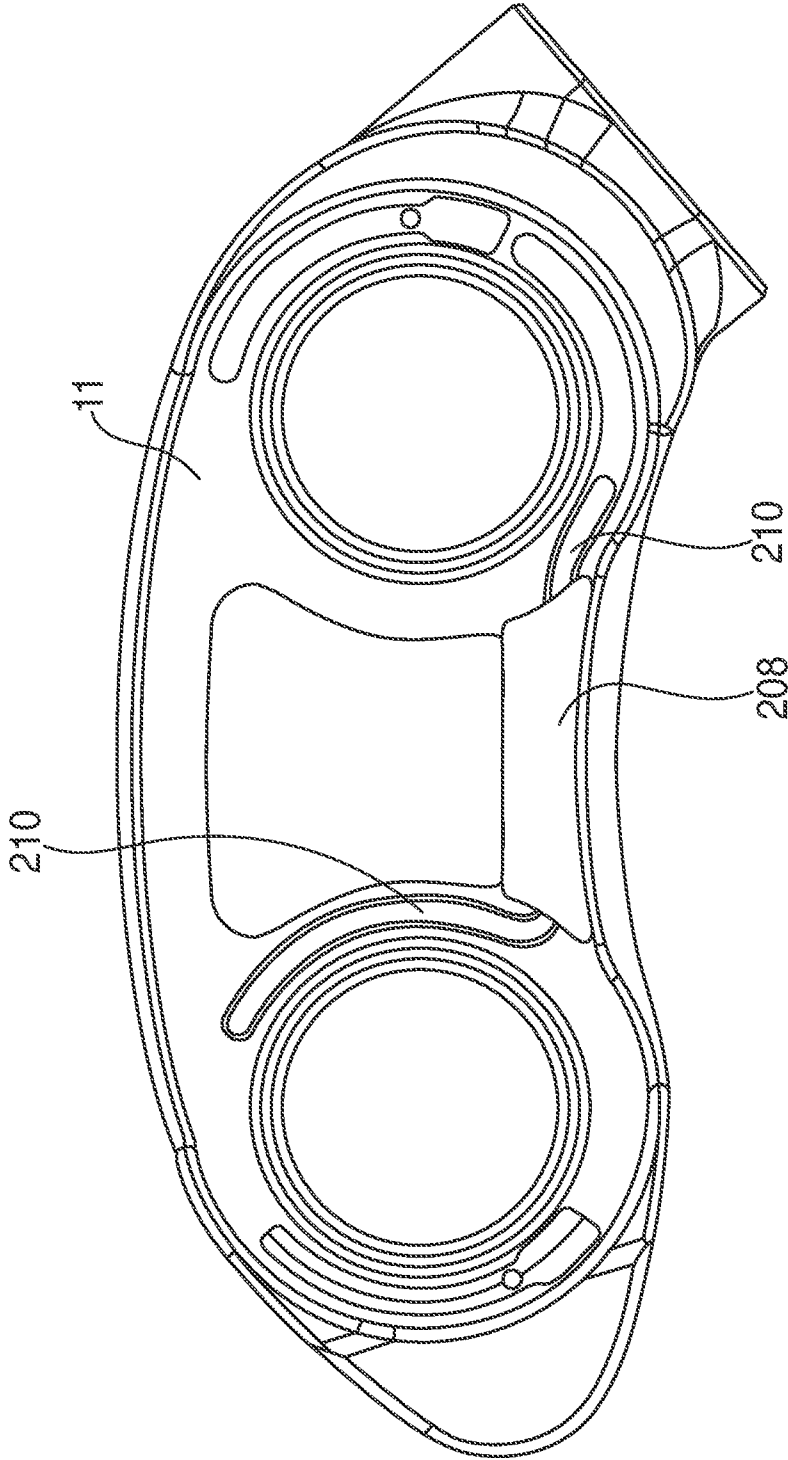

FIG. 45B

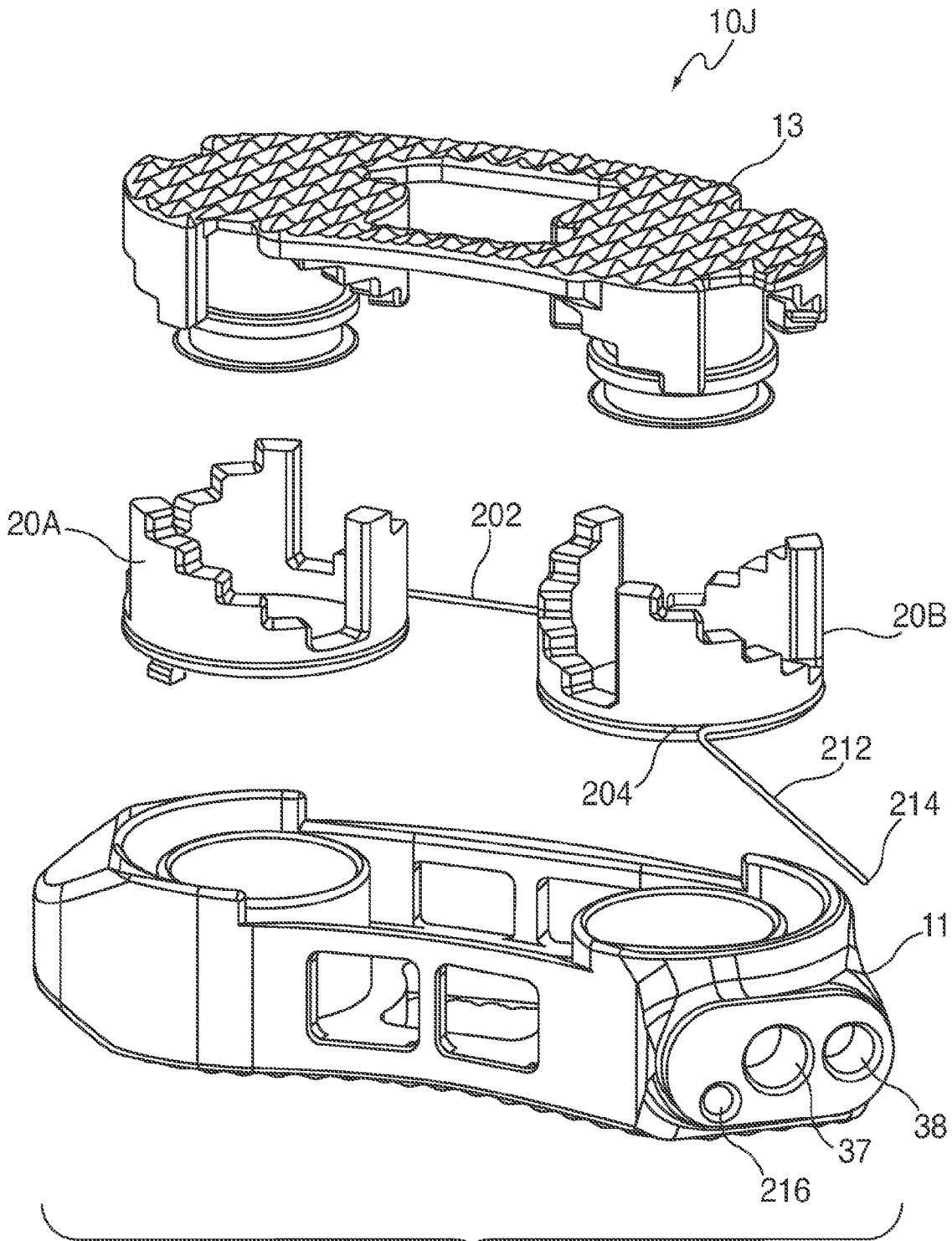

FIG. 46A

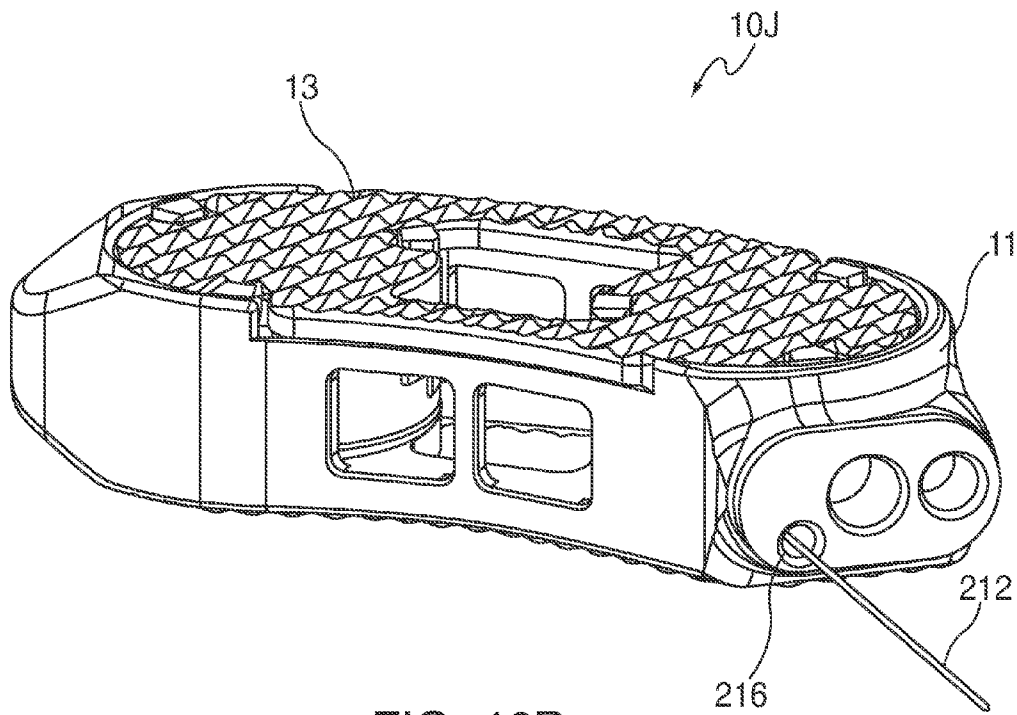

FIG. 46B

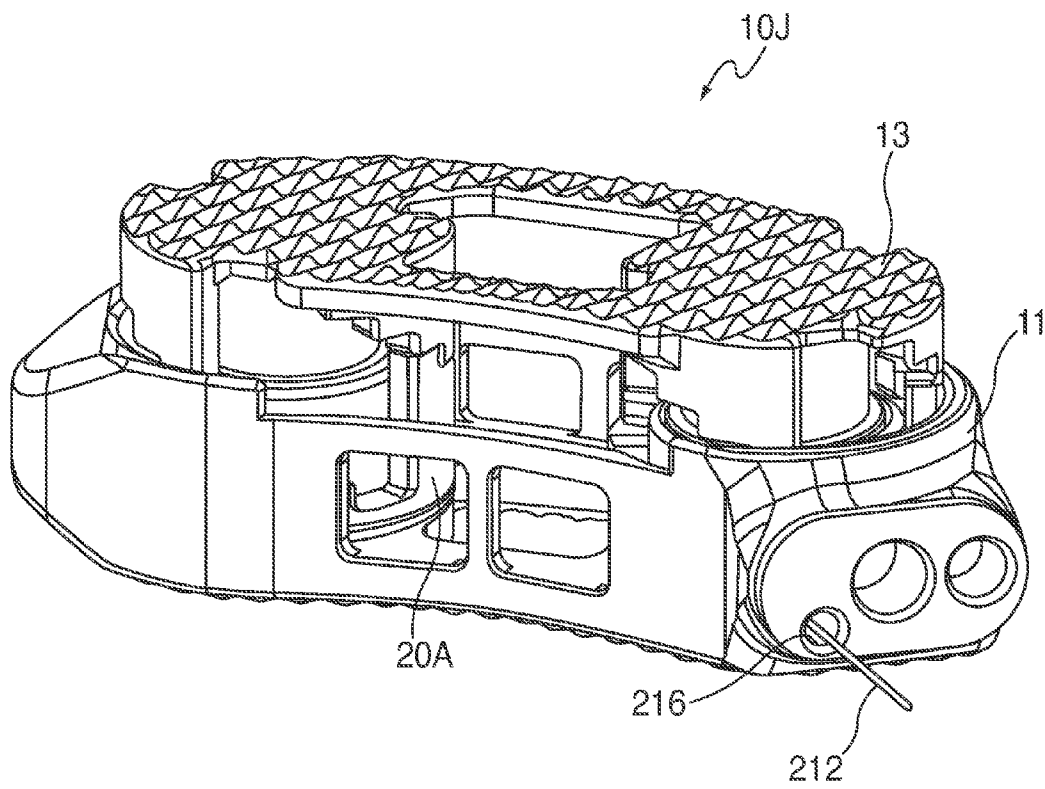

FIG. 46C

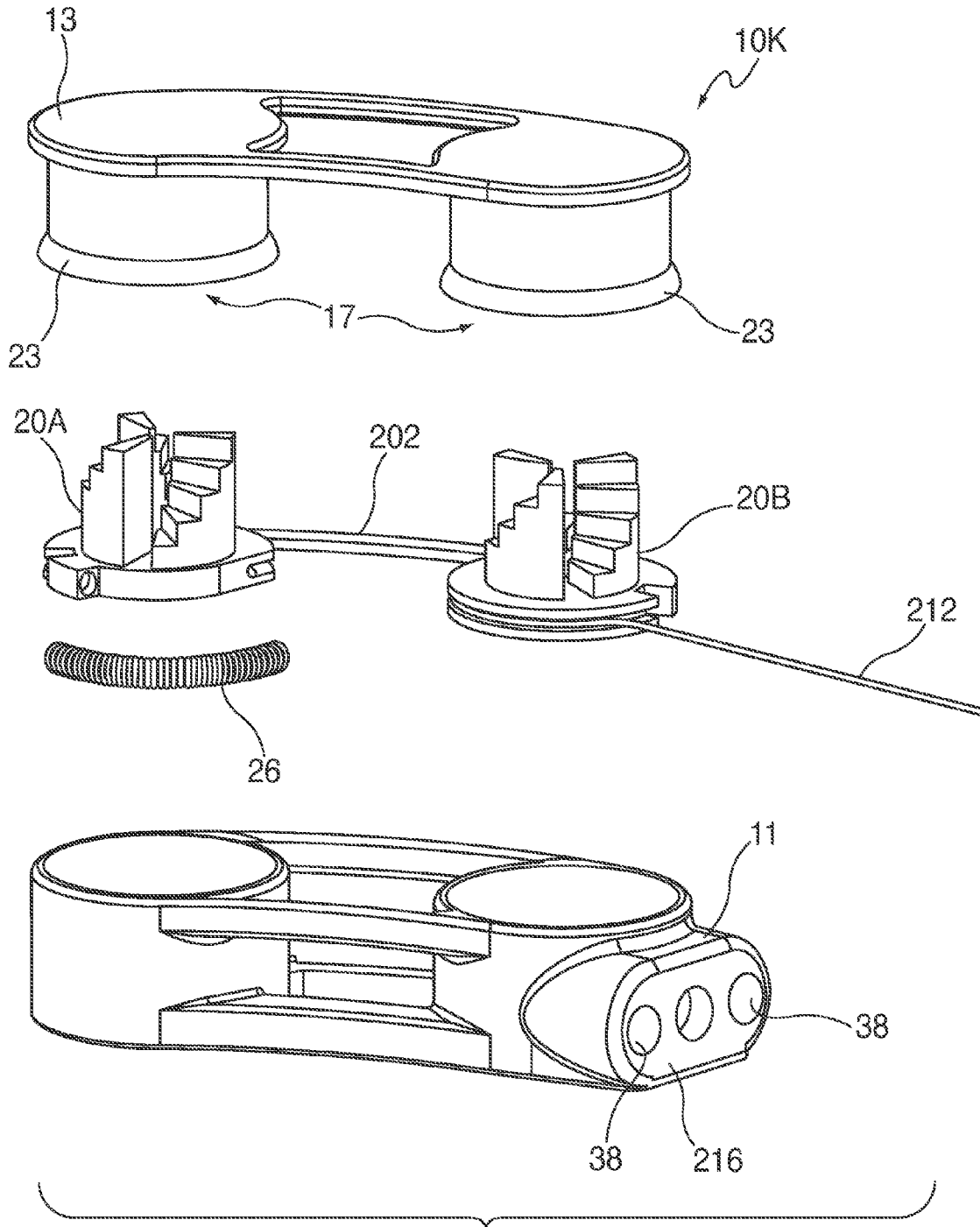

FIG. 47

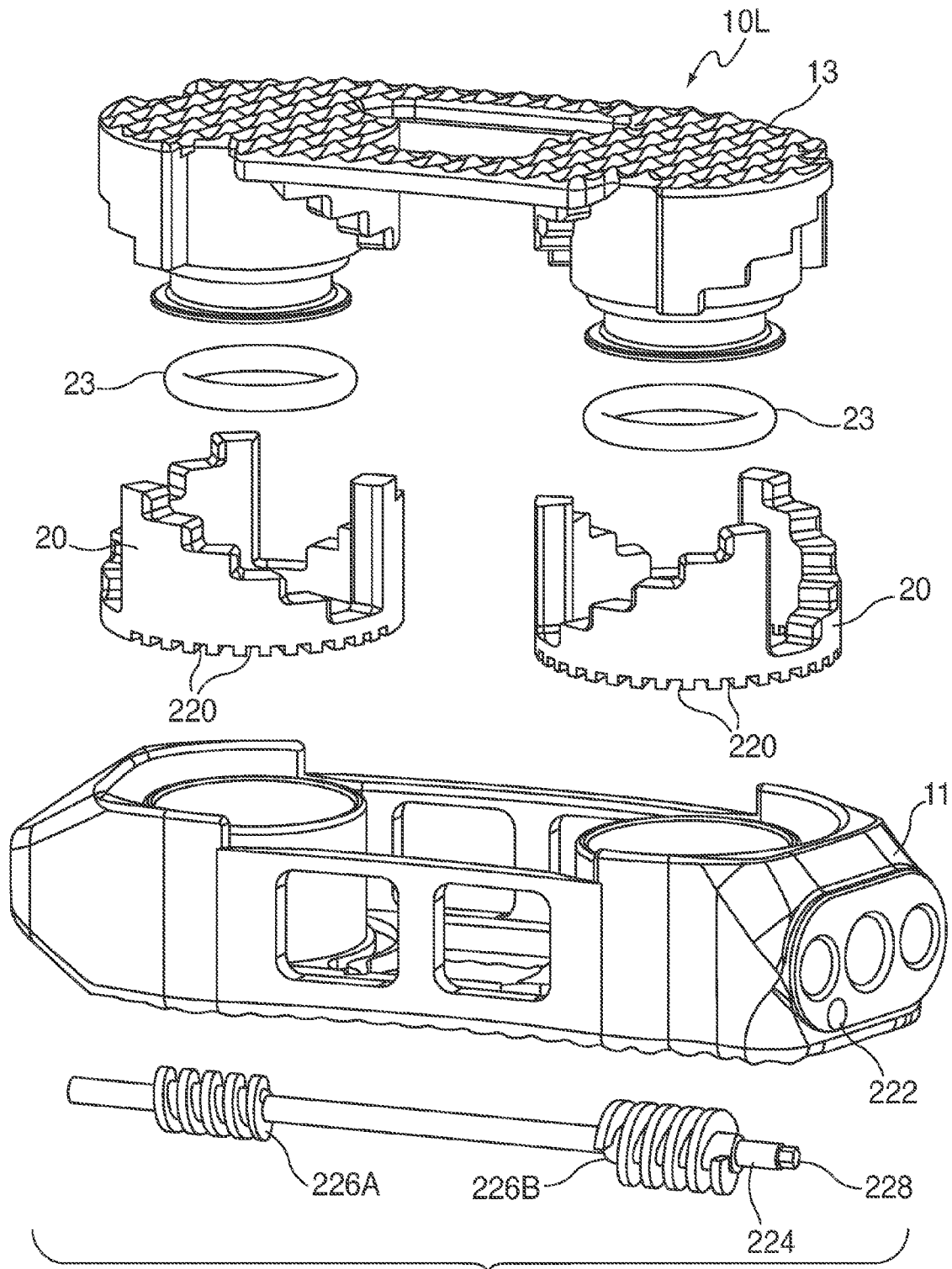
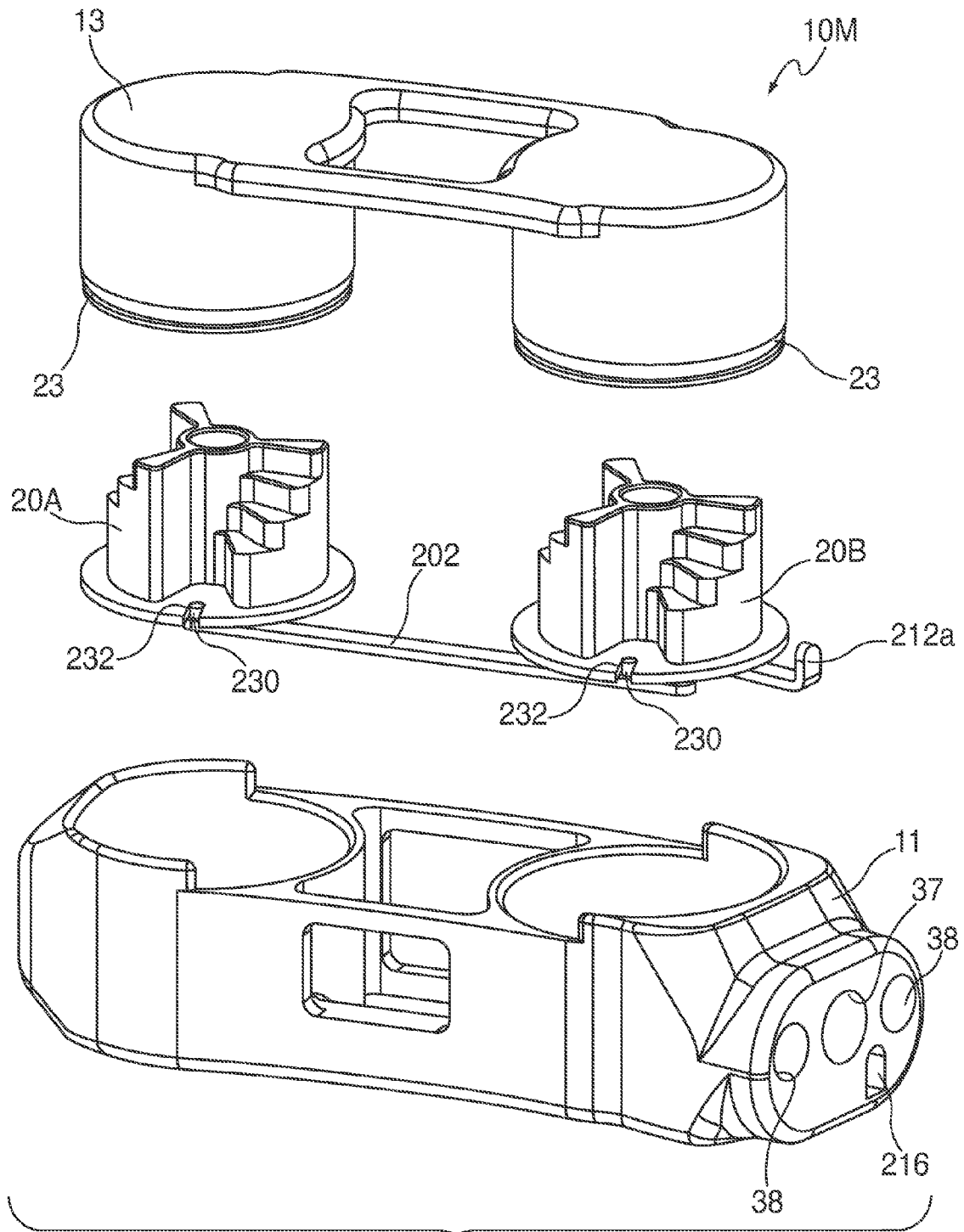

FIG. 48



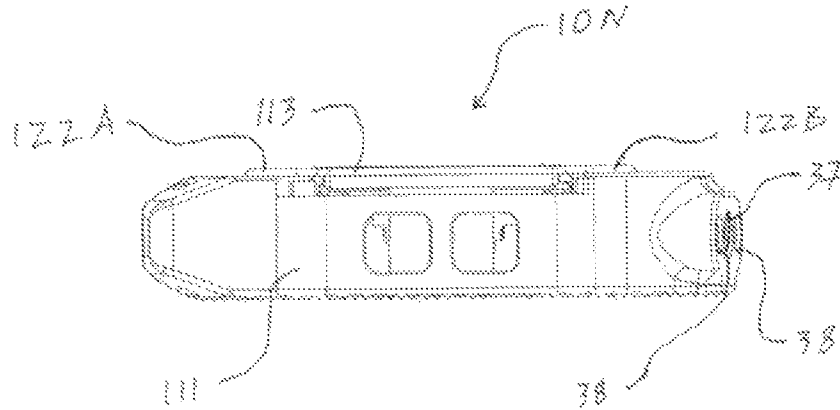

Figure 50A

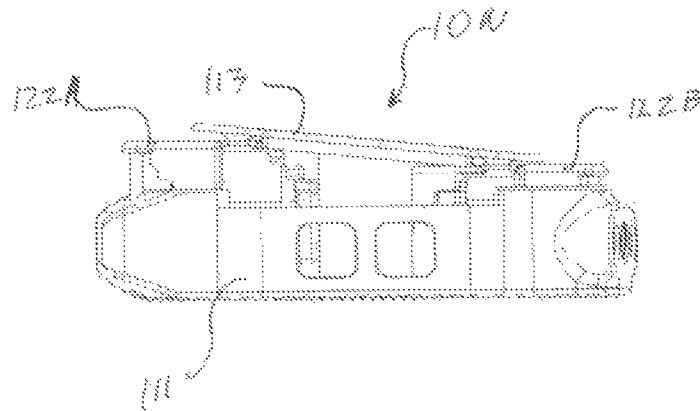

Figure 50B

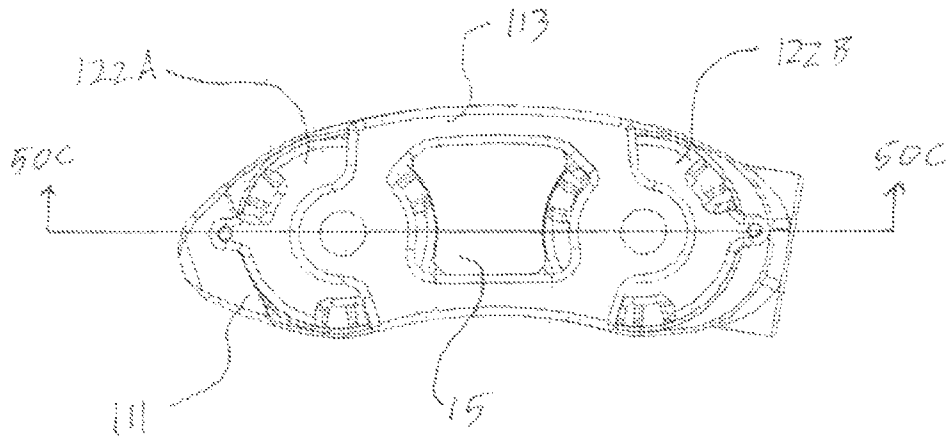

Figure 50C

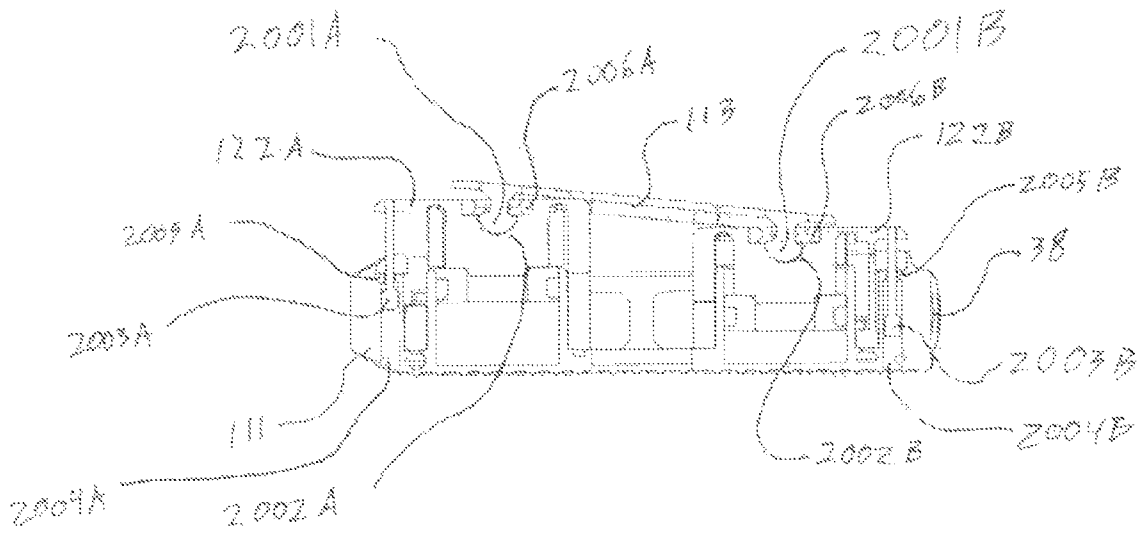

Figure 50D

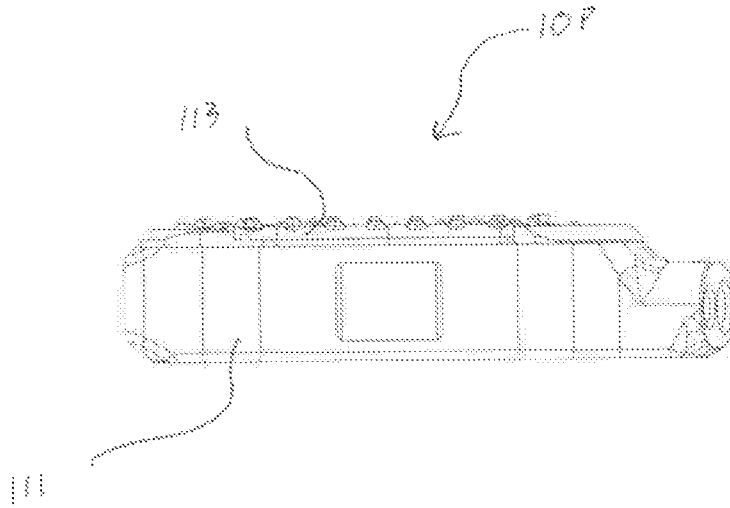

Figure 51A

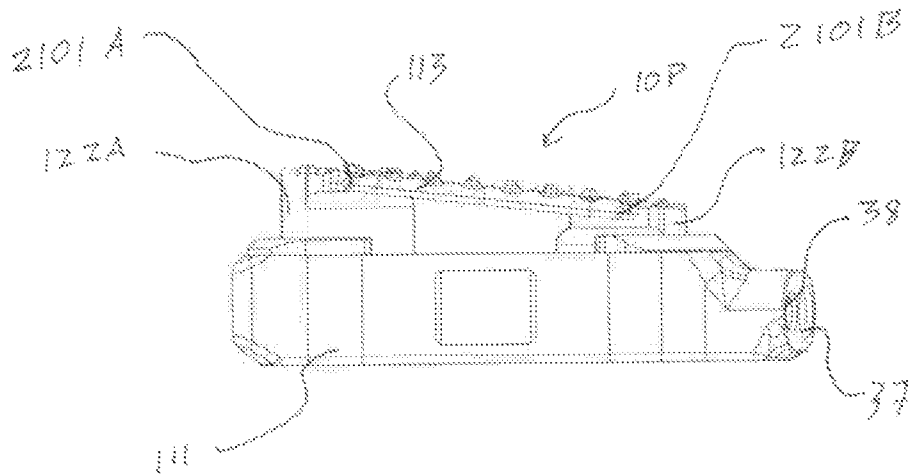

Figure 51B

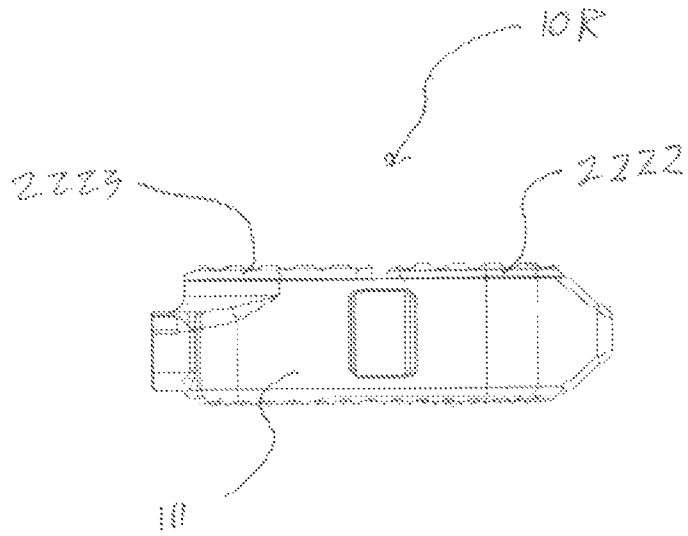

Figure 52A

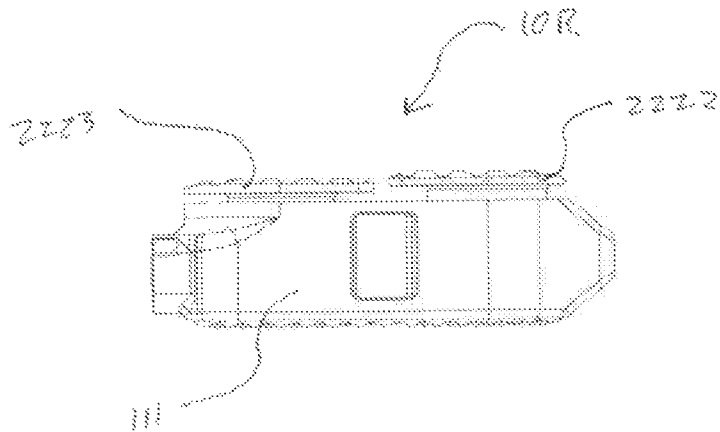

Figure 52B

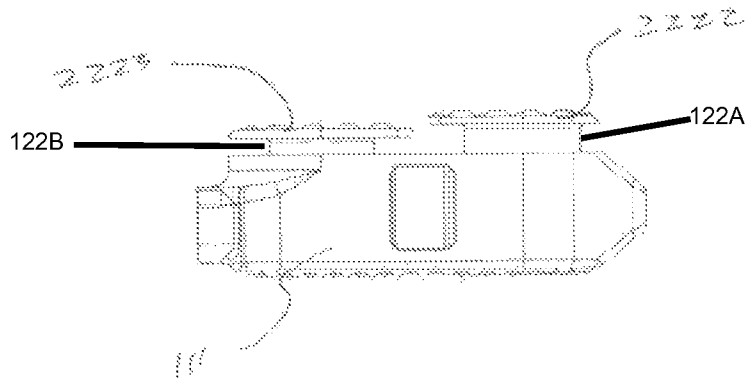

Figure 52C

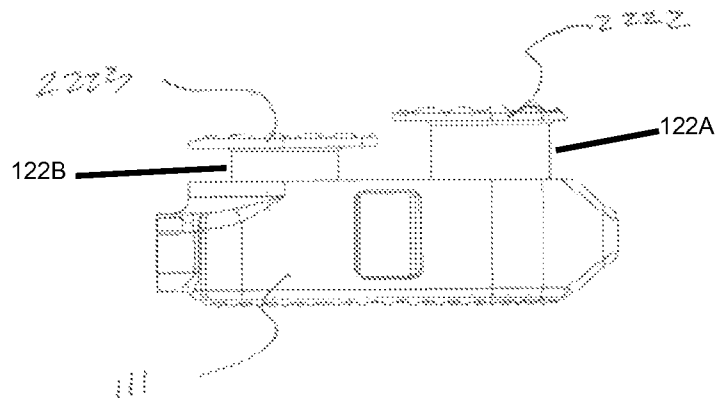

Figure 52D

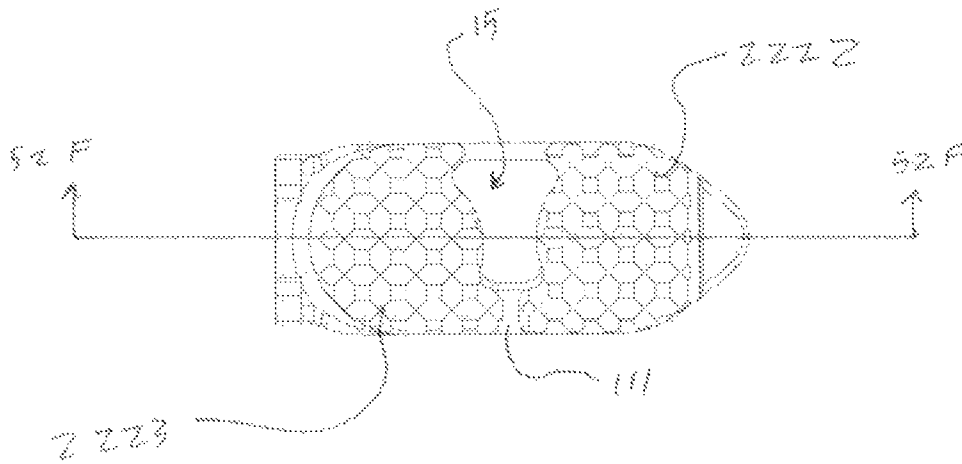

Figure S2E

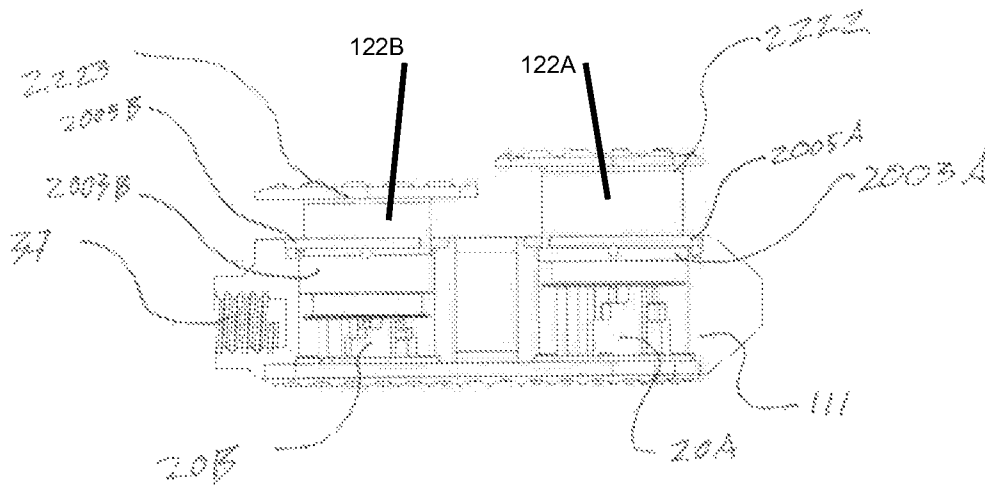

Figure S2F

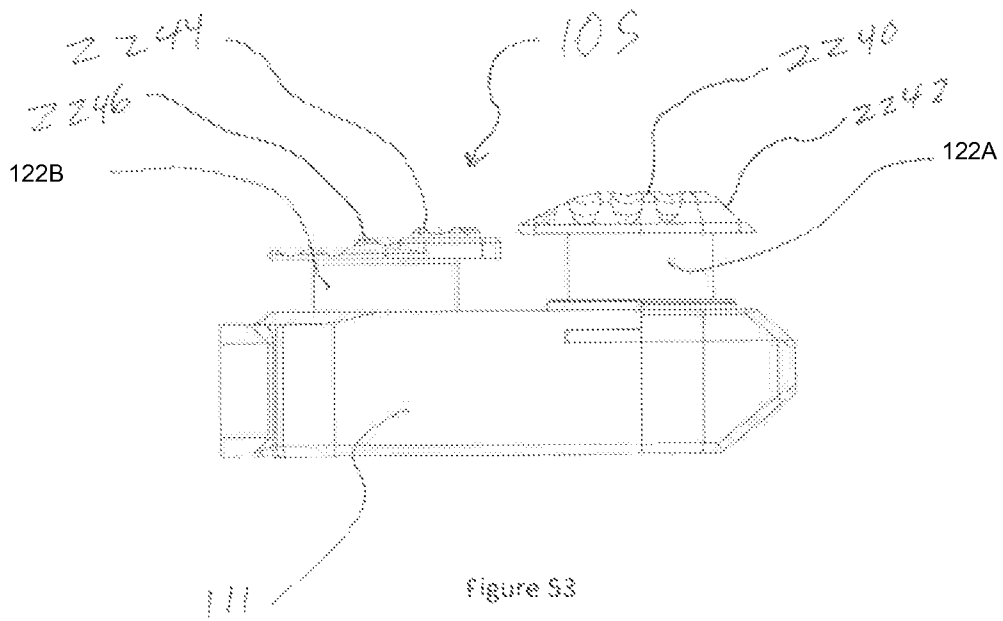

Figure S3

ADJUSTABLE DISTRACTION CAGE WITH LINKED LOCKING MECHANISMS

RELATED APPLICATION DATA

This application is a continuation-in-part of U.S. Nonprovisional patent application Ser. No. 12/787,281, filed on May 25, 2010, entitled "Adjustable Distraction Cage with Linked Locking Mechanisms," which is a continuation-in-part of International Application No. PCT/US2009/67446, designating the United States, filed Dec. 10, 2009, entitled "Lockable Expanding Spine Cage," and U.S. Nonprovisional patent application Ser. No. 12/380,840, filed on Mar. 4, 2009, entitled "Lockable Spinal Implant," which is a nonprovisional of U.S. Provisional Patent Application Ser. No. 61/201,518, filed on Dec. 10, 2008, entitled "Lockable Spinal Implant."

This application is also related to U.S. patent application Ser. No. 11/692,800, filed Mar. 28, 2007, entitled "Selectively Expanding Spine Cage, Hydraulically Controllable in Three Dimensions for Vertebral Body Replacement," which is a continuation-in-part of U.S. Nonprovisional patent application Ser. No. 11/535,432, filed Sep. 26, 2006, entitled "Selectively Expanding Spine Cage, Hydraulically Controllable in Three Dimensions for Enhanced Spinal Infusion," which is a nonprovisional of U.S. Provisional Patent Application Ser. No. 60/720,784, filed Sep. 26, 2005, entitled "Selectively Expanding Spine Cage, Hydraulically Controllable in Three Dimensions for Enhanced Spinal Infusion."

Each of the above listed applications is incorporated herein by reference in its entirety.

FIELD OF THE INVENTION

The invention relates to devices and methods for stabilizing the vertebral motion segment. More specifically, the field of the invention relates to an expandable spinal implant with locking elements configured to lock the implant in an expanded configuration within an intervertebral space to provide controlled spinal correction in three dimensions for improved spinal intervertebral body distraction and fusion.

BACKGROUND

A conventional spine cage or implant is characterized by a kidney bean shaped body which is typically inserted posteriorly through the neuroforamen of the distracted spine after a trial implant creates a pathway. Existing devices for interbody stabilization have important and significant limitations, including inability to expand and distract the end plates or to fix the device in place to prevent relative movement between the device and an adjacent vertebral body. Current devices for interbody stabilization include static spacers composed of titanium, PEEK, and high performance thermoplastic polymer produced by VICTREX, (Victrex USA Inc, 3A Caledon Court; Greenville, S.C. 29615), carbon fiber, or resorbable polymers. Moreover, current interbody spacers do not maintain interbody lordosis and can contribute to the formation of a straight or even kyphotic segment and the clinical problem of "flatback syndrome." Separation of vertebral end plates increases space available for the neural elements, specifically the neural foramen. Existing static cages do not reliably improve space for the neural elements. Therefore, what is needed is a spinal implant that will provide space for the neural elements posteriorly between the vertebral bodies, or at least maintain the natural bone contours to avoid neuropraxia (nerve stretch) or encroachment.

Conventional devices for intervertebral body stabilization include poor interface between bone and the biomaterial of the device. Conventional static interbody spacers form a weak interface between bone and biomaterial. Although the surface of such implants is typically provided with a series of ridges or coated with hydroxyapatite, the ridges may be in parallel with applied horizontal vectors or side-to-side motion. That is, the ridges or coatings on the implant offer little resistance to movement applied to either side of the end plates. Thus, nonunion is common in allograft, titanium and polymer spacers, due to motion between the implant and host bone.

SUMMARY OF THE DISCLOSURE

This invention is generally directed to a spinal implant for insertion between superior and second vertebral end plates after partial or total removal of a spinal disc. The spinal implant embodying features of the invention has a contracted configuration for easy installation between adjacent vertebral bodies and an expanded configuration to support the vertebrae in a desirable position. More specifically, the implant has a plurality of inter-engagable elements which locks the implant in an expanded configuration to hold the vertebral or joint sections in the desired positions.

The invention is particularly directed to a spinal implant suitable for placement between superior and inferior vertebral bodies. The spinal implant has a first member or top plate for engaging an end of the superior vertebral body and a second member or base for engaging an end of the inferior vertebral body and has one or more extendable support elements preferably with one or more top end plates that engage vertebral bodies in the expanded configuration. The one or more extendable support elements have a first contracted configuration to facilitate deployment of the implant between the superior and inferior vertebral bodies and safely past sensitive neural elements and a second or an extended configuration to engage the end plates of the vertebral bodies. The implant has a locking system with linked locking elements that mechanically engage or interlock with the extendable support element or the first member to lock the implant between the superior and inferior vertebral bodies in an expanded configuration.

The extendable support element(s) may be extended in a variety of ways such as with fluid pressure, e.g. hydraulic fluid or gas, by mechanical force, such as a threaded connection with a rotating driving member or other suitable means. Fluidic displacement is preferred. The extendable support element(s) are disposed in cylinders which support and guide the extendable support elements when they are extended. However, the locking system is separate from the extendable support member and cylinder receiving the supporter member, although the extending support member may initiate the locking system and the support member and cylinder may have lock support members attached thereto.

In one exemplary system, the spinal implant having features of the invention comprises an inferior pressure applying member or base with a first bone engaging surface, one or more extendable support members cooperating with the base and a superior pressure applying member such as a top end plate with a second bone engaging surface that is coupled to the at least one extendable member. The spinal implant preferably has a plurality of engaging locking elements that are configured to independently lock one or more of the extendable support members or pressure applying members in an extended configuration to thereby provide desired disc height between adjacent vertebrae.

The spinal implant or selectively expanding spine cage (SEC) embodying features of the invention is particularly

suitable for posterior or transforaminal insertion between superior and inferior vertebral end plates as described in copending application Ser. No. 11/535,432, filed Sep. 26, 2006, and Ser. No. 11/692,800, filed Mar. 28, 2007. The implant has a contracted or unexpanded configuration which

allows easy deployment and is typically about 0.5 to about 1 cm in maximum short transverse dimension so as to enable minimally invasive insertion posteriorly between vertebral pedicles through a working space of approximately 1 cm in diameter.

In one exemplary embodiment, the spinal implant for placement between adjacent vertebral bodies as described above has an upper locking member with stepped supporting surfaces on the underside thereof and a lower locking member with stepped supporting surfaces on the top side thereof which are configured to engage the stepped supporting surface of the upper locking member to lock the implant in an extended configuration. Extension of the expandable members, such as bellows or pistons; or other appropriately sized mechanisms, such as cams or screws, to raise the superior pressure applying member increases longitudinal spacing between the upper and lower locking members. Relative motion, rotational or linear, between the upper and lower locking members causes the stepped supporting surfaces of the lower locking members and the stepped supporting surfaces of the upper locking members to re-engage to fix the locking members in an increased spaced apart relationship and thereby lock the implant in the extended configuration.

Since the vertebral end plates are held together at one end by a ligament much like a clamshell, as the implant expands against the vertebral end plates, the amount of vertical expansion can be adjusted to create the desired anterior/posterior correction angle.

A minimally invasive downsized insertion tool, such as described in the above referenced applications, both inserts the unexpanded implant posteriorly and provides the hydraulic or mechanical lines communicating with the interior of the implant. The insertion tool may also provide a line for communicating the liquid or slurry bone graft material into the intervertebral space for subsequent fusion. Advantageously, hydraulic lines are small size tubing to allow for high hydraulic pressure without danger of the lines bursting.

Due to the mechanical advantage provided by a hydraulic system or a proximally operated mechanical system, the implant has minimized size and diameter in its unexpanded state that is smaller than the diameter of a prepared neuroforamen. The implant thus can be inserted transforaminally and engaged between the end plates of the adjacent vertebra to effectively distract the intervertebral area, restore space for neural elements, stabilize the motion segment and eliminate pathological segmental motion. The implant enhances spine arthrodesis by creating a rigid spine segment.

The implant is preferably provided with a hollow interior to enable a comparatively large quantity of bone growth conductive or inductive agents to be contained therein that through openings communicate directly to adjacent bone. Importantly, this results in fixation forces greater than adjacent bone and soft tissue failure forces. The implant can be used to promote fusion, and/or to correct deformities such as scoliosis, kyphosis, and spondylolisthesis.

The clinical goals of the implant and the method for its insertion provide a minimally invasive risk of trauma to nerve roots, reduce pain, improve function, and permit early mobilization of the patient after fusion surgery. The fixation elements maintain the implant in a desired position until healing (fusion or arthrodesis) occurs. At this point, the implant is incorporated inside bone and its role becomes quiescent.

Thus, a feature of the invention is that an implant can be inserted posteriorly between vertebral pedicles in only a working space of about ½ cm and then be expanded from about 100% to about 200%, typically about 160%, of its original insertion size and locked in that position to provide a closely controlled full range of permanent spinal correction in three dimensions. These and other advantages of the invention will become more apparent from the following detailed description and the accompanying exemplary drawings.

In other embodiments of the invention, extendable, locking, bone engaging anchors are provided to ensure that the implant is positively engaged with the bone after insertion.

In one implementation, the present disclosure is directed to a lockable, extendable spinal implant for placement between first and second vertebral bodies. The implant includes: first and second bone engaging members each having a surface configured to respectively engage opposed first and second vertebral bodies; extension means acting between the first and second bone engaging members to control extension of the bone engaging members between contracted and extended configurations; first and second fixed lock members fixed to one of the first and second bone engaging members and extending towards the opposite bone engaging member, the fixed lock members being spaced apart and each having a fixed locking surface; first and second moveable lock members captured between the first and second bone engaging members for cooperation with the fixed lock members, each moveable lock member having a moveable locking surface configured to engage an opposed fixed locking surface on one the fixed lock member to prevent contraction of the extension means; a locking actuator configured to engage the moveable locking surfaces with the fixed locking surfaces; and a link member operatively connected between the first and second moveable lock members to coordinate movement therebetween.

In another implementation, the present disclosure is directed to a lockable, extendable spinal implant for placement between first and second vertebral bodies. The implant includes: first and second bone engaging members each having a surface configured to respectively engage opposed first and second vertebral bodies; first and second pistons disposed on one the bone engaging member and cooperating with mating cylinders disposed on the opposite bone engaging member, the pistons moveable between a contracted configuration within the cylinders and an extended configuration extending from the cylinders; first and second arcuate, fixed lock members, each having a fixed locking surface, mounted to one of the bone engaging members, each disposed around one the piston, the fixed lock members extending towards the opposite bone engaging member; first and second moveable lock members, each formed around one the cylinder for cooperation with the fixed lock members, each moveable lock member having a moveable locking surface configured to engage an opposed fixed locking surface on one the fixed lock member to prevent contraction of the extension means; at least one biasing element acting on at least one the moveable lock member to bias the member into engagement with its associated fixed lock member; and a link member operatively connected between the first and second moveable lock members to coordinate movement therebetween and force the other moveable lock member into engagement with its associated fixed lock.

In still another implementation, the present disclosure is directed to a lockable, extendable spinal implant for placement between first and second vertebral bodies. The implant includes: first and second bone engaging members each having a surface configured to respectively engage opposed first

and second vertebral bodies; first and second pistons disposed on one the bone engaging member and cooperating with mating cylinders disposed on the opposite bone engaging member, the pistons moveable between a contracted configuration within the cylinders and an extended configuration extending from the cylinders; first and second arcuate, fixed lock members, each having a fixed locking surface, mounted to one of the bone engaging members, each disposed inside one the piston, the fixed lock members extending towards the opposite bone engaging member; first and second moveable lock members, each formed inside one the cylinder for cooperation with the fixed lock members, each moveable lock member having a moveable locking surface configured to engage an opposed fixed locking surface on one the fixed lock member to prevent contraction of the extension means; at least one biasing element acting on at least one the moveable lock member to bias the member into engagement with its associated fixed lock member; and a link member operatively connected between the first and second moveable lock members to coordinate movement therebetween and force the other moveable lock member into engagement with its associated fixed lock.

BRIEF DESCRIPTION OF THE DRAWINGS

For the purpose of illustrating the invention, the drawings show aspects of one or more embodiments of the invention. However, it should be understood that the present invention is not limited to the precise arrangements and instrumentalities shown in the drawings, wherein:

FIG. 1 is a perspective view of an intervertebral implant in a contracted configuration embodying features of the invention.

FIG. 2 is a perspective view of the implant shown in FIG. 1 in an expanded configuration.

FIG. 3 is an exploded perspective view of the implant shown in FIG. 1.

FIG. 4A is a top view of the implant shown in FIG. 1.

FIG. 4B is a side cross-sectional view through line 4B-4B of the implant shown in FIG. 4A.

FIG. 5A is a perspective view of a lower part of the implant shown in FIG. 1 with upper portions and bottom face removed.

FIG. 5B is a bottom view of the lower portion shown in FIG. 5A.

FIG. 6A is a perspective view of the upper portion of the implant shown in FIG. 1 with the lower portion removed.

FIG. 6B is an enlarged perspective view of the staircase-like lower lock support shown in FIG. 3.

FIG. 7 is a partial side view of one of the locking mechanisms of the implant shown in FIG. 2.

FIGS. 8A-9B are partial side views of the locking mechanism in FIG. 7 shown in different expanded and locked configurations.

FIGS. 10A and 10B of the locking mechanism illustrate the expanded but unlocked configuration in FIG. 10A and the expanded and locked configuration in FIG. 10B.

FIGS. 11A and 11B are perspective views of the lower lock support and spring locking actuator illustrating the operation thereof.

FIG. 11C is a perspective view of an alternative locking mechanism and locking actuator embodying features of the invention.

FIGS. 12A-12C are perspective views of alternative lower lock support designs embodying features of the invention.

FIGS. 13A-13B are perspective and side views respectively of an alternative implant embodying features of the invention which has an articulating top end plate.

FIG. 14A is an exploded perspective view of yet another alternative implant embodying features of the invention which has the lower lock supports within the extendable pistons.

FIG. 14B is a top view of the implant shown in FIG. 14A.

FIG. 14C is a side cross-sectional view through line 14C-14C of the implant shown in FIG. 14B.

FIG. 15 is a perspective view of an alternative implant design having features of the invention wherein the locking mechanism surrounds a central opening in the top end plate.

FIG. 16 is a perspective view of an alternative implant design having features of the invention wherein the expanding piston is centrally located and locking mechanisms are provided on both sides of the expanding piston.

FIG. 17 is a simplified schematic illustration of an alternative implant design having ratchet and pawl locking members between the top and bottom plates of the implant.

FIG. 18 is a perspective view of an alternative implant design with ratchet and pawl locking members between the top and bottom plates of the implant.

FIG. 19 is a cross-sectional perspective view of an implant design with ratchet and cantilevered spring members between the top and bottom plates of the implant.

FIGS. 20A-29 schematically illustrate various means for locking an expanding member of implants in extended configurations embodying features of the invention.

FIG. 30 is a perspective view of yet another alternative implant design having features of the invention wherein the locking mechanism has straight upper and lower interfitting lock supports.

FIG. 31A-31G illustrate an alternative implant locking mechanism in which a wire-form surrounds a pair of upper support members with grooves configured to receive the wire-form.

FIGS. 32A and 32B are perspective views of a further alternative embodiment of the present invention including locking, conical bone engaging anchors.

FIGS. 33A-C are perspective views showing alternative bone engaging anchors.

FIGS. 34A and 34B are perspective cross-sectional views of another alternative embodiment of the present invention including locking, screw-threaded bone engaging anchors.

FIGS. 35A and 35B are perspective views of yet another embodiment of the present invention including locking, telescoping bone engaging surfaces.

FIGS. 36A and 36B are cross-sectional views of another exemplary embodiment of the present invention shown in a collapsed and an expanded configuration respectively.

FIG. 36C is a posterior perspective view of the embodiment in FIG. 36B, shown in an expanded state.

FIGS. 37A and 37B are end views of a lift mechanism according to a further exemplary embodiment of the present invention, shown in a collapsed and an expanded configuration respectively.

FIGS. 38A and 38B are end views of a cross section of another embodiment of the present invention utilizing the lift mechanism shown in FIGS. 37A and 37B, shown in a collapsed and an expanded configuration, respectively.

FIGS. 39A and 39B are top views of the respective embodiments shown in FIGS. 38A and 38B with the top plate removed.

FIG. 40 is an anterior perspective view of the embodiment shown in FIG. 38B.

7

FIG. 41 is a posterior perspective view of still another exemplary embodiment of the present invention, shown in an expanded configuration.

FIG. 42 is a perspective view of a lift mechanism of the embodiment of FIG. 41.

FIGS. 43A and 43B are cross-sectional views of the embodiment of FIG. 41 shown in a collapsed and an expanded configuration, respectively.

FIG. 44 is an exploded perspective view of another embodiment of the current invention.

FIG. 45A is a partial inferior perspective of another embodiment of the present invention.

FIG. 45B is a partial top view of the embodiment shown in FIG. 45A.

FIG. 46A is an exploded perspective view of another embodiment of the current invention.

FIGS. 46B and 46C are superior perspective views of the embodiment shown in FIG. 46A in the collapsed and expanded configurations respectively.

FIG. 47 is an exploded perspective view of another embodiment of the current invention.

FIG. 48 is an exploded perspective view of another embodiment of the current invention.

FIG. 49 is an exploded perspective view of another embodiment of the current invention.

FIG. 50A is a side view of an alternative implant design in a collapsed configuration having an articulating top plate.

FIG. 50B is a side view of the implant shown in FIG. 50A in an expanded configuration.

FIG. 50C is a top view of the implant shown in FIG. 50B.

FIG. 50D is a side cross-sectional through line 50D of the implant shown in FIG. 50C.

FIG. 51A is a side view of an alternative implant in a collapsed configuration having an articulating top plate.

FIG. 51B is a side view of the implant shown in FIG. 51A in an expanded configuration.

FIG. 52A is a side view of an alternative implant in a collapsed configuration embodying features of the invention which has two separated top plates.

FIG. 52B is a side view of the implant shown in FIG. 52A in a slightly expanded configuration.

FIG. 52C is a side view of the implant shown in FIG. 52B in a more expanded configuration.

FIG. 52D is a side view of the implant shown in FIG. 52C in a fully expanded configuration.

FIG. 52E is a top view of the implant shown in FIG. 52D.

FIG. 52F is a side cross-sectional through line 52F of the housing 111 of the implant shown in FIG. 52E.

FIG. 53 is a side view of an alternative implant design in a fully expanded configuration having two separated top plates.

DETAILED DESCRIPTION

FIGS. 1-10B illustrate an example of an intervertebral implant 10, a Selectively Expandable Cage (SEC), having features of the invention. The implant 10 generally includes a housing 11, a housing base 12, an interlocking top end plate 13, a bottom end plate 14, an interior cavity 15 within the housing 11 and a pair of cylinders 16. The top and bottom end plates are the bone engaging members of the implant, providing surfaces for engaging vertebrae above and below the implant when placed in the patient. Upper lock supports 17 are attached to the underside of the top end plate 13 thus forming fixed lock members and have multi-stepped lower support surfaces 18 much like an inverted staircase. Lower lock supports 20, having multi-stepped upper support surfaces 21 surround cylinders 16 much like an upright staircase.

8

The multi-stepped support surfaces form the locking surfaces of the lock supports. Pistons 22 are secured to the under surface of top end plate 13. Seal members 23 are slidably disposed within the cylinders 16 and are mounted on pistons 22. The upper surface 24 of bottom end plate 14 is provided with locking actuator channels 25 which partially receive spring locking actuators 26. The base 12 of the housing 11 has arcuate slots 27 which are configured to slidably receive the depending elements 28 or locking actuator transfer element of the lower lock supports 20 and partially receive the spring locking actuators 26. Depending elements 28 engage the forward end 30 of spring locking actuators 26. The spring locking actuators 26 are initially in a compressed configuration so that upon the extension of the top end plate 13 and the attached upper lock supports 17, the lower lock supports 20 rotate about the cylinders 16 due to the force applied by the biased spring locking actuator 26 thus forming moveable lock members. This causes the lock support surfaces 21 of the lower lock supports 20 to engage support surfaces 18 of the upper lock supports so as to lock the top end plate 13 in an extended configuration. The support surfaces 18 of the upper lock supports 17 and the support surfaces 21 of the lower lock supports 20 are tiered with multiple steps so that the implant 10 can be locked at several different expanded heights. The underside stepped support surfaces 18 of the upper lock support 17 may be provided with increasing riser height (alignment faces 46) in the upward direction to provide smaller incremental expansion near the end of the piston expansion. In addition or alternatively, the stepped support surfaces 21 of the lower lock support 20 may be provided with decreasing riser height in the upward direction for the same reason. A variety of riser heights of the upper lock support 17 or lower lock support 20 can be provided. The lowermost stepped support surface 18 of the upper lock support 17 and the uppermost stepped support surface 21 of the lower lock support 20 may be provided with various lengths and widths to ensure better support.

As can be seen in FIG. 2 there are two sets of upper lock supports 17 attached to the top end plate 13 and there are two sets of lower lock supports 20 in this embodiment, but a single set or more than two sets of upper and lower lock supports can also be used to lock the implant 10 in the expanded state. Also shown, for example, in FIG. 2 are cylinders 16 and pistons 22, which provide one example of extension means in embodiments of the present invention. Other examples of extension means are described herein below in connection with alternative embodiments of the invention.

The implant 10 is configured to be implanted between opposing vertebral bodies in the spine to facilitate bony fusion between those vertebral bodies. The implant 10 is shown in its collapsed or contracted configuration in FIG. 1 and in one example of its expanded configuration in FIG. 2. In the collapsed state, the implant 10 can be inserted easily into the intervertebral body space through a minimal incision and with minimal tissue removal. Once in that space, the implant 10 can be expanded against the two opposing vertebral bodies to distract them and thereby restore height to the intervertebral space. This provides stable opposition of the implant 10 to both vertebral bodies and optimizes the bony fusion process. The fusion process can also be enhanced by filling the interior cavity 15 with autologous bone graft, a bone growth enabling matrix, and/or bone growth stimulating substances prior to and/or after insertion into the body.

Further details of individual parts of the implant 10 are depicted in FIGS. 3, 4A and 4B. Pistons 22 are attached to the underside of the top end plate 13 which are configured to support seal members 23 which run inside of cylinders 16

9

located in the housing 11. When the cylinders 16 are pressurized as will be described in more detail below, the seals 23 running inside the cylinders 16 and pistons 22 slidably disposed within the seals are vertically displaced, translating the top end plate 13 vertically above the housing 11. Lower lock supports 20 are located around the outer wall of the cylinders 16. When the top end plate 13 is vertically displaced, which in turn displaces the attached upper lock supports 17, the lower lock supports are rotated by the biased locking actuators 26 to a locking position. Arcuate locking actuator channels 25 in the top surface of bottom plate 14 and the arcuate slots 27 in the housing base 12 confines the locking actuators 26 to the housing 11.

Additional details of the housing 11 are depicted in FIGS. 5A and 5B. The housing 11 comprises an outer wall 31 and cylinders 16 which are secured to housing base 12. The outer wall 31 supports a leading nose 32 on the distal end and a delivery boss 33 on the proximal end. The leading nose 32 has inwardly directed side tapered faces 34 and top tapered face 35 and bottom tapered face 36. These tapered faces 34, 35 and 36 enable non-traumatic insertion of the implant 10 past neural elements and between the vertebral bodies. The delivery boss 33 contains a delivery tool anchor 37 which allows secure attachment of the implant 10 to a delivery tool (not shown), which is illustrated in co-pending application Ser. No. 11/535,432, filed Sep. 26, 2006, and Ser. No. 11/692,800, filed Mar. 28, 2007 for insertion into a vertebral space. The delivery boss 33 also contains pressure input ports 38 which are used to deliver a pressurized fluid to the interiors of cylinders 16. The outer wall 31 of the housing 11 also provides side openings 40 which provide space for bony in-growth into central cavity 15 in the housing 11 and provide radiolucent openings for the radiographic imaging of the process of bony in-growth. The housing base 12 also contains pressure channels 41 which deliver pressurized fluid from the pressure input ports 38 to the interior of cylinders 16. Although the housing base 12 of implant 10 is depicted with independent pressure channel 41 for each cylinder 16, other embodiments can contain one or more branching pressure channels for delivering pressurized fluid to two or more cylinders 16. As previously mentioned, the housing base 12 also has locking actuator slots 27 which hold and guide the locking actuators 26. The locking actuator slots 27 contain a wider portion, locking actuator opening 42, to enable insertion of the locking actuator 26 into the channels defined by the locking actuator slots 27 in housing base 12 and the locking actuator channels 25 in the bottom end plate 14. The housing base 12 also has optional alignment bosses 19 which align the bottom end plate 14 to the housing 11 via optional alignment holes 9.

FIGS. 6A and 6B illustrate further details of the top end plate 13 and the lower lock support 20. The two sets of pistons 22 and upper lock supports 17 are joined by connecting members or struts 44. The pistons 22 have seal bosses 45 on which the seals 23 are mounted. The upper lock supports 17 have tiered lower support surfaces 18 and risers or alignment faces 46. The tiered or stepped support surfaces 18 of the upper lock supports 17 engage the stepped or tiered support surfaces 21 of the lower lock supports 20. The alignment faces 46 of the upper lock support are configured to engage the alignment faces 47 of the lower lock supports 20. The uppermost support surface of the lower lock support 20 has a lock support stop 50 which engages with the lower most alignment faces 46 of the upper lock support to prevent the lower lock support 20 from over rotating as it engages the upper lock support 17. The bottom of the lower lock support 20 also has the locking actuator transfer element 28 which engages the forward end

10

30 of the spring locking actuator 26 to transfer the actuation force from the locking actuator 26 to the lower lock support 20.

FIGS. 7 through 10B show details of the selectively expanding locking sequence of implant 10 with the housing 11 removed. The collapsed configuration is shown in FIG. 7 with the support surfaces 18 of the upper lock support 17 resting on the support surfaces 21 of the lower lock support 20. The locking actuator 26 is a biasing element, such as a spring, that engages the depending element or locking actuator transfer element 28 to urge the alignment faces of the lock supports in a direction where they contact. Thus, in one exemplary embodiment, the alignment faces 47 of the lower lock supports 20 are forced against the alignment faces 46 of the upper lock support 17. The lock support stops 50 fit within the lower lock stop relief 52 (shown best in FIG. 6A) on the top end plate 13. When the cylinders 16 are pressurized, the pistons 22 raise the top end plate 13 and attached upper lock supports 17 (straight arrow) moving the support surfaces 18 of the upper lock support 17 off of the support surfaces 21 and moving the lower alignment faces 46 past the upper alignment faces 47. When the alignment faces 46 of the upper lock support 17 have cleared the alignment faces 47 of the lower lock support 20, the locking actuators 26 (in this embodiment a compressed coiled spring) engaging the locking actuator transfer element 28 force the lower lock supports 20 to rotate (curved arrow in FIGS. 8B and 9B). The support surfaces 21 of the rotating lower lock supports 20 move to the next lower level of the support surfaces 18 of the raised upper lock supports 17 until the alignment faces 47 of the lower lock supports 20 engage the next level of the alignment faces 46 of the upper lock supports 17. The lower lock support 20 and upper lock support 17 then lock the top end plate 13 at this expanded level. This process repeats itself at each locking level (FIGS. 8A, 8B, 9A, 9B and 10A) until the top level (or somewhere between) is reached as shown in FIG. 10B. At this top level, the locking actuators 26 engage the locking actuator transfer elements 28 and the lower lock supports 20 are rotated so the lowermost alignment surface 46 of the upper lock support 17 engages lock support stop 50 of the uppermost support surface 21 of the lower lock support 20. At this highest locked level only the lowest support surfaces 18 of the upper lock supports 17 and the highest support surfaces 21 are engaged providing all of the locking support. As can be seen from FIGS. 10A and 10B the lowest support surfaces 18 of the upper lock supports 17 and the highest support surfaces 21 of the lower lock supports 20 can be wider than the other support faces to provide sufficient support material when only these two faces are engaged.

FIGS. 11A and 11B illustrate the operation of locking actuator 26. In this embodiment the spring locking actuator 26 is compressed into an arc beneath the lower lock support 20. One end of the spring locking actuator 26 is constrained by the housing 11 (not shown) and the other is engaged with the locking actuator transfer element 28. When the lower alignment faces 46 of the upper lock support 17 are raised above the upper alignment faces 47 of the lower lock support 20 by the extension of piston 22, the locking actuator 26 pushes against the locking actuator transfer element 28 and rotates the lower lock support 20 in a clockwise direction (arrow) as viewed from above. It should be noted that in the embodiment of the current implant as described thus far, the angular orientation of the tiered upper and lower support surfaces 18 and 21 can vary when there is more than one set of supports. As shown in FIG. 3 the proximal lower support surfaces 21 are oriented clockwise as viewed from above and the distal lower support surfaces 21 are oriented counter-

11

clockwise. This opposite orientation provides enhanced locking support for rotational forces applied to the implant.

An alternative locking actuator **26a** is shown in FIG. **11C** as a torsion spring. This locking actuator **26a** has constraining tab **53** secured to the lower lock support **20** and constraining tab **54** secured to the housing **11**. Just as the compression spring shown in FIGS. **11A** and **11B** applies a force to the lower lock support **20** to rotate it, the torsion spring in FIG. **11C** does the same. An extension spring would work equally as well as a locking actuator **26a**. Spring actuators can be made of an appropriate biocompatible material such as stainless steel, NITINOL, titanium or a suitable polymer. Locking actuators are not limited to springs. A wide variety of mechanisms can be used to actuate the lower lock supports **20**, including but not limited to, a linear drive, an externally actuated tensile member, a worm gear, an inflated member such as a balloon or bellows, a magnet, a rotational drive such as a micro motor, a super elastic shape memory element, and the like.

FIG. **12A** through **12C** show variations of the lower lock support **20** described above. In FIG. **12A** a tri-set lock support **20a** is shown whereby there are three sets of upper support surfaces **21a**, upper alignment surfaces **47a** and lock support stops **50a** rather than the two sets described above. This tri-set lower lock support **20a** has two advantages over the two sets design, 1) there are three support columns rather than two locking the implant **10** in an expanded state thereby creating a more stable lock and 2) the tri-set lower lock support **20a** has to move or rotate much less for each locking level. This last advantage is significant when the locking actuator is a spring such as spring locking actuator **26** as this places less strain on the spring to achieve the required locking force at each step. Each lower lock support column will have a corresponding upper lock support column (not shown). The upper support surfaces **21** and lower support surfaces **18** are not limited to two or three sets of surfaces. Any number of sets of support surfaces including a single set may be employed.

FIG. **12B** shows an inter-digitating lower lock support **20b**. Each of the inter-digitating upper support surfaces **21b** on the inter-digitating lock support **20b** is paired with an inter-digitating stop **50b** which when paired with matching inter-digitating support surfaces and stops of an upper lock support (not shown) prevents the inter-digitating support surfaces **21b** from moving relative to the inter-digitating support surfaces of an upper lock support to unlock the implant without the inter-digitating lower support faces first lifting above the inter-digitating stop **50b**. This design provides an enhanced locking feature. Upper alignment surfaces **47b** are again provided.

Generally the lower support surfaces **18** and the upper support surfaces **21** are horizontal to maximize vertical support in the locked implant. However, the locking support **20c** shown in FIG. **12C** provides an enhanced locking feature by providing inclined support surfaces **21c** which have a slope relative to the horizontal which requires matching inclined lower support surfaces on the upper lock supports (not shown) to be lifted above the inclined upper support surfaces **21c** before the upper lock support can be rotated to unlock the implant.

FIGS. **12A** and **12C** show various lengths of locking actuator transfer elements or depending elements **28**. The locking actuator transfer element **28** can vary in length depending on how much engagement is desired between the locking actuator transfer element **28** and the locking actuator slots **27**. The locking actuator transfer element **28** includes one or more transfer element tabs **29a** and **29c** which vertically constrain the lower lock support **20** to the locking actuator slots **27** in

12

the housing **11**. The wider locking actuator opening **42** described above (see FIG. **5B**) enables insertion of the locking actuator transfer element **28** with transfer element tabs **29a** and **29c** into the locking actuator slots **27** in housing base **12** at the rotational position where the locking actuator transfer element **28** is aligned with the locking actuator opening **42**. In other rotational positions the transfer element tabs are constrained by lateral extensions on the sides of the narrower locking actuator slots **27**. In this manner the locking actuator transfer element **28** provides both the function of transferring force from the locking actuator **26** to the lower lock support **20** as well as constraining the lower lock support **20** to the housing **11**. This later function prevents the frictional forces between the lower alignment faces **46** and the upper alignment faces **47** created by the biased spring locking actuator **26** from lifting the lower lock support **20** along with the upper lock support **17** when the upper lock support **17** is lifted by the piston **22**.

As an alternative to the locking actuator transfer element **28**, the embodiment shown in FIG. **12B** depicts a locking actuator guide channel **80**. This locking actuator guide channel **80** engages a tensile member (not shown) which transfers actuation force from the locking actuator **26** to the lower lock support **20**. Tensile members can be any of a number of known elements such as sutures made of polymers or natural materials, metal cable, plastic or metal rod and the like.

FIGS. **13A** and **13B** illustrate an alternative design of an implant **110** embodying features of the invention. The implant **110** has independent actuation of the distal piston **122a** and proximal piston **122b**. The two pistons **122a** and **122b** are interconnected by an articulating top end plate **113** which allows independent lift and locking of each side of the implant **110**. This independent lift and locking of both ends of the implant **110** enables the implant to conform to intervertebral end plates that have uneven lateral heights between them. Further, this independent lift and locking allows the implant **110** to be used to create varying lateral heights between vertebral end plates which can be useful to compensate for a scoliosis in the spine.

Implant **110** has a housing **111** which has an alternative delivery tool anchor **160** located in it as well as alternative pressure input ports **137**. A variety of anchor designs or pressure ports can be used with any of the embodiments of the current device without departing from the scope of this invention. Lock and unlock access ports **138** are also located on this housing **111**. These ports are used to guide lock and unlock mechanisms (not shown) which can be manipulated externally to the implant **110** to actuate the lower lock support **120** to not only move it under the upper lock support **117** to hold the piston **122b** and articulating end plate **113** in an expanded position, but also to move the lower lock support **120** away from the upper lock support **117** to allow the piston **122b** and articulating end plate **113** to collapse back into the housing **111**. This later action may be desirable to remove the implant **110** from or reposition the implant within the intervertebral space. A variety of lock/unlock mechanisms can be used with the current invention such as but not limited by, a tensile member including suture thread and metallic cable, a compressive member such as a metallic or polymer rod, pressurized fluid, a rotating drive, a super elastic shape memory element, and the like.

FIGS. **14A-14C** depict yet another alternative implant **210** that embodies features of the invention. Implant **210** has an interfacing top plate **213** which connects to separate and freely rotating pistons **222** via the piston capture plate **270** on the interfacing top plate **213** and the piston heads **271** on the rotating pistons **222ab**. The rotating pistons **222ab** also inte-

riorly contain upper lock supports 217 with support faces 218 and alignment faces 246. Seals 223 are mounted on the rotating pistons 222ab and the seals 223 and rotating pistons 222ab fit into internal cylinders 216 that are located on the housing 211. The internal cylinders 216 have lower lock supports 220 with support surfaces 221 and alignment faces 247 as well as lower retaining features 273. The housing 211 also contains one or more pressure input ports 238.

In use, the implant 210 is inserted into the intervertebral body space in a collapsed state and fluid pressure is delivered through the pressure input port(s) 238 to the internal cylinder(s) 216 to raise the seal(s) 223 and rotating piston(s) 222ab out of the internal cylinder(s) thereby raising the interfacing top plate 213 and expanding the implant 210. Once the rotating pistons 222ab have been raised such that the lower alignment faces 246 of the upper lock supports 217 have cleared the upper alignment surfaces 247 of lower lock supports 220, an actuator (not shown) rotates the rotating pistons 222ab such that the lower support surfaces 218 of the upper lock supports 217 are moved above the upper support surfaces 221 of the lower lock supports 220, to thereby lock the implant 210 in the expanded configuration. The actuator can be one or more tensile members such as suture threads or cables that extend from the user into the implant 210 through the lock and unlock access ports 238 on the interfacing top plate 213 to the piston head 271. Applying tension to one or more tensile members when the piston is in an extended configuration will rotate the piston heads 271 such that the support surfaces 218 of upper lock supports 217 are moved above the support surfaces 221 of the lower lock supports 220 thereby locking the implant 210. Alternatively or in addition to applying tension to lock the implant 210 in an expanded configuration, applying tension to one or more tensile members will rotate the piston heads 271 such that the lower support surfaces 218 are moved away from the upper support surfaces 221 thereby unlocking the implant 210 and allowing the rotating pistons 222ab to seat back into the internal cylinders 216 such that the implant 210 is once again in a collapsed configuration.

FIG. 15 illustrates an alternative implant design 310 embodying features of the invention which has a housing 311, top end plate 313 and pistons 322 similar to the prior embodiments. This implant 310 has upper lock supports 317 and lower lock supports 320 within a central portion of the implant. The upper lock supports 317 are secured to the top end plate 313 and the lower lock supports 320 are secured to the base 314 with depending elements (not shown) as was described above and are moved as in the prior embodiments.

FIG. 16 illustrates an alternative implant design 410 embodying features of the invention which has a housing 411, top end plate 413 and a centrally located piston 422 similar to the prior embodiments. This implant 410 has upper lock supports 417 and lower lock supports 420 distal and proximal to the centrally located cylinder 416 and piston 422. The upper lock supports 417 are secured to the top end plate 413 and the lower lock supports 420 are secured to the base 412 and are moved as in the prior embodiments via depending elements (not shown) as was described above.

FIG. 17 shows another alternative implant 510 which has a pair of pistons 522 and which has a locking support system which includes ratchets 521 on the base 512 and pawls 517 pivotally mounted to and depending from the top end plate 513. Expansion of the pistons 522 causes the free ends 518 of pawls 517 to engage recesses 520 in the ratchets 521 so as to lock the top end plate 513 in an extended configuration.

FIG. 18 illustrates another alternative implant design 610 which is similar to that shown in FIG. 17. In this embodiment the free end of the pawl 617 has a plurality of teeth 618 to

provide greater effective contact between the pawl 617 and the ratchet 621 for locking of the implant 610.

FIG. 19 is a cross section embodiment, showing implant 710 embodying features of the invention. In this embodiment the pistons 722 are surrounded by upper lock support 717 which has at least one cantilever extension ending at the support surface 718. The support surfaces 718 are captured by the recessed support surfaces 721 which are located on the inner wall of the housing 711. Once the pistons 722 are expanded in an upward direction, the support surfaces 718 of the upper lock support 717 engages the recessed support surfaces 721 locking the implant 710 in place. The upper lock support 717 can be rotated relative to the piston 722 and housing 711 to disengage the support surfaces 718 from the support surfaces 721 to unlock the implant 710 and lower the pistons 722 as needed. Alternatively the implant 710 can be unlocked by rotating the upper lock support constraints 775 relative to the upper lock support 717 to press on the cantilever extensions and disengage the support surfaces 718 from the support surfaces 721.

FIGS. 20A-31B illustrate a variety of suitable means for locking extendable members such as pistons in extended configurations. FIGS. 20A, 20B, 21A, 21B, and 22-31B show variations of lower lock supports and upper lock supports. In each of these variations there are support surfaces on the lower lock supports which engage support surfaces on the upper lock supports.

In FIGS. 20A and 20B support surfaces 818 comprise grooves set into the upper lock support 817. The lower lock support 820 is a U-shaped tong which is configured to advance (as indicated by the arrow in FIG. 20A) towards the upper lock support 817 and to engage one of the grooves with its upper support surface 821 for locking an implant not shown in these drawings. Lower lock support 820 is withdrawn (as indicated by the arrow in FIG. 20B) from the groove to disengage the lower lock support and unlock the implant.

In the variation shown in FIG. 21A, the lower lock support 920 is a plate with an upper lock clearance opening 970 that is shaped to allow passage of the cylindrical flat-sided upper lock support 917 through the lower lock support 920 (arrow). As shown in FIG. 21B, once the lower lock support 920 is positioned at the desired location it can be rotated approximately 90° (arrow) to engage the support surfaces of the lower lock support 920 with the support surfaces 918 of the upper lock support 917. The shape of the upper lock support 917 and mating upper lock clearance opening 970 on the lower lock support 920 are not restricted to the profile shown in FIGS. 21A and 21B nor is the locking actuation restricted to 90° rotation of one of the elements but can vary to any number of shapes that allow passage in one configuration but constraint when one of the elements is moved to another configuration.

In FIG. 22, the upper lock support 1017 is a cylinder with notches cut to create support surfaces 1018. The lower lock support 1020 is a pivoting pin 1070 with a pawl 1071 for the lower support surface 1021. In the configuration shown, the support surface is biased as indicated by the arrow 1072 to allow the upper lock support 1017 to rise with an expandable member of an implant and to prevent the upper lock support from dropping. This allows the device to lock at each level when the subsequent support surface 1018 of the upper lock support 1017 engages the support surface 1021 of the lower lock support 1020. In this variation having features of the present invention, the upper lock support 1017 can also be lowered by moving the pivoting pin 1070 of the lower lock

15

support 1020 away from the upper lock support 1017 to disengage the support surface 1021 from the support surface 1018.

FIG. 23 shows yet another embodiment having features of the invention where the lower lock support 1120 is a pin 5 configured to engage (arrow) support surfaces 1118 located in the upper lock support 1117. The lower lock support 1120 does not have to engage the full thickness of the upper lock support 1117 as shown in this figure, nor does the support surface 1118 have to extend through the entire thickness of the upper lock support 1117 but rather can engage any portion 10 of the upper lock support 1117 that is sufficient to lock an implant in position. This embodiment also allows a variety of shapes of pins 1120 and matching support surfaces 1118.

In FIG. 24 the lower lock support 1220 is a grip with two 15 pivoting jaws 1270, the ends of which have support surfaces 1221. The upper lock support 1217 has a series of notches which have the support surfaces 1218. A lock actuator such as a compressive spring (not shown) can apply force (as shown by the arrows 1272) to the grip base extensions 1273 to lock 20 the device. This variation having features of the invention allows the upper lock support 1217 to move upwards but prevents downward motion thereof. Downward motion of the upper lock support 1217 can be allowed by reversing the force on grip base extensions 1273.

Not all locking systems embodying features of the invention require the engagement of support surfaces of the upper lock supports directly on top of the support surfaces of the lower lock supports. A frictional support can be created to lock the device as shown in FIGS. 25 through 32.

In FIG. 25 the upper lock support 1317 has one or more flat surfaces as the support surfaces 1318. The lower lock support 1320 has one or more pivoting pawls that have a support surface 1321 that engage the support surface 1318 and supports a load (arrow).

In FIG. 26 the upper lock support 1417 has an exterior support face 1418 which is gripped by the support face 1421 on the inner diameter of the wrapped lower lock support 1420. This lower lock support 1420 can be a torsion spring that in its free state grips the upper lock support 1417 and releases 40 the upper lock support when a force (arrows) is applied to one or more of its ends 1470 as shown to increase the spring's inner diameter. The reverse is possible where in its free state the lower lock support 1420 allows movement of the upper lock support 1417 inside the inner diameter. When a tensile force is applied to the ends 1470 to reduce the inner diameter, the lower lock support grips the support surface 1418 of the upper lock support 1417 to lock the implant.

FIGS. 27A and 27B show another variation which can be described as a canted washer type device. The lower lock support 1520 is a plate with an upper lock clearance opening 1570 which allows relative movement of the upper lock support 1517 as shown in FIG. 27A. When the lower lock support 1520 is canted as shown in FIG. 28B, the edge of the upper lock clearance opening 1570 comprises a lower support surface 1521 which engages the upper support surface 1518 which is the outer surface of the upper lock support 1517 locking it relative to the lower lock support 1520.

Yet another variation of the gripping lock of the current invention is shown in FIG. 28. In this variation the lower lock support 1620 comprises one or more jaws which have support surfaces 1621 that are configured to be forced against the support surface 1618 of the upper lock support 1617 to produce friction to lock the device in place.

FIG. 29 illustrates a lower lock support 1720 which comprises a pivot and pawl as has been detailed above. The end of the pawl comprises a lower support surface 1721 which

16

engages an upper support surface 1718 on the upper lock support 1717. In this embodiment the upper lock support 1717 is rotated counter clockwise by an expanding element (not shown). This rotation in turn raises the piston 1722 which expands the implant. In this manner the upper lock support 1717 is integrated into the lifting mechanism to engage the lower lock support 1720 and lock the implant as it expands.

FIG. 30 illustrates yet another alternative implant 1810, similar to that shown in FIG. 1 except that the upper locking member 1817 and lower locking member 1818 have a linear shape rather than the arcuate shape of the prior embodiments. The implant 1810 generally has a housing 1811, a top plate 1813, a bottom plate 1814, pistons 1822 and cylinders 1816. The upper locking member 1817 has support surfaces 1818 and the lower locking member 1820 has support surfaces 1821. The implant 1810 has a locking actuator (not shown).

FIGS. 31A-31G illustrate another implant 1910 embodying features of the invention which have upper locking members 1917 with grooves 1970 having support surfaces 1918 and lower locking member 1920 with locking surfaces 1921. The lower locking member 1920 is a wire-form which encircles the exterior of both upper locking members 1917 and is configured to seat within the grooves 1970. Expansion of the lower locking member 1920 (arrows in FIG. 31B) by the locking actuator (not shown) causes the lower locking member 1920 to be pulled out of the groove 1970 and allows the upper locking member 1917 to rise with the expansion of the implant. Release of this expansion of the lower locking member 1920 (arrows in FIG. 31A) allows the lower locking member 1920 to seat back into the groove 1970 locking the implant 1910.

FIG. 31G illustrates a detail of an alternative implant 1910a embodying features of the invention which have upper locking members 1917a with grooves 1970a having support surfaces 1918a and lower locking member 1920a with locking surfaces 1921a. The lower locking member 1920a is a wire-form which encircles the exterior of both upper locking members 1917a and is configured to seat within the grooves 1970a. The support surface 1918a locks on the support surface 1921a when there is a compressive or downward force (hollow arrow) on the upper locking member 1917a locking the implant 1910a. Upward force or extension (solid arrow) of the upper locking member 1917a causes the lower locking member 1920a to ride on the disengaging surface 1919a and out of the groove 1970a allowing the upper locking member 1917a to rise with the expansion of the implant 1910a.

In a further aspect of the present invention, a piston/cylinder and locking arrangement as described above may be used to deploy extendable bone anchors. For example, implant 10A with conical bone engaging anchors 60 as shown in FIGS. 32A and 32B may be constructed with pistons 22 and cylinders 16 as described above in connection with implant 10 and shown, for example, in FIGS. 2, 3 and 4B. Implant 10A has a housing 11 as previously described and may include other previously described features such as interior cavity 15 for bone growth stimulating substances. However, in this embodiment, instead of upper interlocking end plate 13, the two pistons 22 individually terminate with conical bone engaging anchors 60. The bone engaging anchors, including sharp leading tip 62, form surface for engaging the vertebral body.

As shown in FIG. 32A, bone engaging anchors 60 are in a contracted configuration, within housing 11, to facilitate insertion of implant 10A. Using hydraulic actuation as previously described, bone engaging anchors 60 are moved to an extended configuration as shown in FIG. 32B, wherein at least leading tip 62 extends beyond housing 11 to engage and

anchor in the bone. In order to ensure that the bone engaging anchors remain firmly engaged in the bone, locking mechanisms including multi-stepped upper and lower lock supports 17, 20 as previously described in connection with implant 10 and shown, e.g. in FIGS. 6A-12C, are provided to support each anchor 60 in the extended configuration. With this arrangement, the extended and locked anchor 60 helps to retain the implant in place.

A variety of alternatives are possible for the bone engaging anchor according to the invention as illustrated in FIGS. 33A-C. For example, implant 10B in FIG. 33A includes bone engaging anchors formed as spike 60A and blade 60B. Blade 60B can be particularly effective in preventing motion along the insertion path after deployment. In this case, the length of the blade 60B is aligned in the direction shown by arrow A. This is substantially orthogonal to the direction of implantation (arrow B) and would resist movement in that direction. Implant 10F, shown in FIG. 33B includes further possible variations. In this embodiment, the bone engaging anchors are formed as barbed spikes 60C. Barbs 61 along the shaft of the spikes resist forces that tend to move the tissue away from the implant along the axis of the anchor (much as the screw threaded anchor described below would also resist this force). Also included in implant 10F is a lateral bone engaging anchor 63 for anchoring in laterally oriented tissue. In the illustrated embodiment, lateral anchor 63 includes a plain spike 60A. Lateral anchor 63 is formed in the same manner and with the same components, i.e. piston, cylinder, locking mechanism, etc. as elsewhere described in this application, except that the components are oriented laterally as shown. To provide support for the bone anchor components in this lateral embodiment, housing 11 includes a central member 11A that divides interior cavity 15 into two portions. In the configurations of implants 10B and 10F, the top of piston 22 can also become a bone engaging surface when the anchor member is fully received within the bone. FIG. 33C shows a further alternative implant 10G, including anchors 65 extending obliquely from housing 11, rather than orthogonally. This oblique arrangement is helpful in resisting side to side rotational forces (for example when the patient/spine bends towards the side) and expansion forces. Once again, obliquely extending anchors 65 are essentially identical to other bone engaging anchors described herein except for the oblique orientation. Here, holes 68 are provided in top end plate 66 for the spikes to pass through. In general, bone engaging anchors according to embodiments of the invention should have a relatively small termination (e.g. tip 62) relative to the size of the piston diameter so that the force on the piston created by the hydraulic fluid is proportionally a much greater force at the small anchor termination to enhance its ability to extend into hard bony tissues. It will also be appreciated by persons skilled in the art that the various features of the bone engaging elements, e.g. spike, blade, barbs, etc., described herein may be combined in any desired combination, in addition to the exemplary combinations shown in the figures of the present application.

In another alternative embodiment, illustrated in FIGS. 34A and 34B, implant 10C includes screw-threaded members 64 as bone engaging anchors. Implant 10C also illustrates a further alternative wherein the bone engaging surfaces, such as the anchors, extend from opposite sides of the implant. In this exemplary embodiment, interlocking end plate 13 is replaced with an integrated top end plate 66. Holes 68 are provided for threaded member 64 to pass through. Persons of ordinary skill in the art will appreciate that holes 68 will be located as needed; in the illustrated embodiment one is in top end plate 66 and the other in bottom end plate 14.

Threaded members 64, as bone engaging anchors extend outwardly from pistons 22. In order to rotate the threaded anchors into the bone when the pistons are extended, the inner wall of housing 11 is provided with a screw-threaded surface 70 that mates with corresponding threads 71 cooperating with pistons 22. As previously described, seals 23 act between the pistons 22 and cylinders 16 to prevent leakage of hydraulic fluid. When fluid is pressurized within the cylinders as described for prior embodiments, the piston is extended, but also driven in a circular motion by the engagement between threaded surfaces 70 and 71. The screw-threaded member 64 is thus driven into adjacent bone as it is extended to anchor the implant.

Once again, locking mechanisms as previously described and shown, for example, in FIGS. 6A-12C, may be employed to prevent the bone engaging anchors from becoming unengaged from the bone. In the cross-sectional views of FIGS. 34A and 34B, upper and lower lock supports 17, 20 are visible around the outside of the piston and cylinders. Alternatively, depending on the depth and pitch of the threaded portions, use of a separate locking mechanism may not be required. As persons of ordinary skill will appreciate, the configuration of the threads alone may be sufficient to prevent the anchors from backing out.

FIGS. 35A and 35B illustrate a further aspect of the present invention wherein locking mechanisms as described are utilized to secure telescoping bone engaging surfaces in place. As used herein, telescoping refers to nested, extendable members including at least one intermediate member between a base and bone engaging member.

Referring first to FIG. 35A, implant 10D has substantially planar bone engaging members 72. Bone engaging members 72 are thus similar to the bone engaging members of implant 10, but instead individually actuated without interlocking end plate 13. The piston/cylinder arrangement is also similar to that previously described except that here upper piston 74 is received in intermediate piston 80. Intermediate piston is in turn received in cylinder 16 as was previously described for piston 22. Upper piston 74 is sealed against intermediate cylinder 78 of intermediate piston by upper piston seals 76 (see FIG. 35B).

The telescoping bone engaging members 72 are secured by locking mechanisms in a similar manner to the earlier described embodiments, with the addition of an upper lock support 82 for the upper piston. Intermediate piston 80 is supported by upper lock support 17 and lower lock support 20 as previously described. Upper lock support 82 includes upper and lower lock supports 84, 86. Thus, upper piston 74 is secured to upper lock support 84 of the upper lock set. Lower lock support 86 of the upper lock set is mounted on top of upper lock support 20 of the lower lock set. One difference from the earlier described embodiments is that separate spring actuators 26 are not required for the upper lock set as they may be rotated along with the lower lock set by actuators 26.

Implant 10E, as shown in FIG. 35B includes a further variation in which the planar portion of upper bone engaging surface 88 is effectively annular with a conical anchor 90 at the center. Advantages of embodiments of the present invention including bone engaging anchors include the ability of the anchors to be extended lateral from the long axis of the implant (i.e., the insertion axis) with a relatively high force using the relatively small connection to the implant of the hydraulic line. This is an advantage over other methods that require larger access or larger connections to the implant for larger tools or non-hydraulic extension forces to extend the anchors into the hard, bony tissue.

19

Although the previously described embodiments of the invention included cylinders **16** and pistons **22** expanded with a pressurized fluid as the mechanism used to lift the top end plate away from the bottom end plate, embodiments of the present invention are not limited to only such lift mechanisms. In FIGS. **36A-C** an alternative embodiment of the present invention comprising implant **10F** is shown wherein a pair of bellows **92** replaces the piston and cylinder pairs previously described. One end of bellows **92** is attached to housing **11** and the other end to top end plate **13**. A pressurized fluid added via pressure input ports **38** is directed through bellows orifice **94** into the inside of bellows **92** causing the bellows to expand. The expanding bellows forces top end plate **13** away from housing **11** and lower lock supports **20** are rotated to lock the device in the expanded configuration as was previously described. Bellows **92** can be made of any biocompatible material such as the 316 series of stainless steels, titanium or a titanium alloy, a cobalt chromium alloy, or an implantable polymeric material. The bellows can be of an accordion-like folding configuration as shown in FIGS. **36A-C** or any other regular or irregular configuration which can fit inside of the housing and lock supports in the collapsed configuration and expand sufficiently when pressurized to lift top end plate **13** the desired amount away from housing **11**. Lower lock supports **20** and upper lock supports **17** provide a confining geometry for bellows **92**, which allows use of an irregular bellows configuration. With a bellows arrangement as shown in FIGS. **36A** and **36B**, the amount of lift is not limited as is the case in a cylinder and piston to the amount that the collapsed cylinder and piston overlap.

Other exemplary embodiments do not rely on the use of a pressurized fluid for expansion. For example, FIGS. **37A** and **37B** show an alternative rotating cam lift mechanism **93**. Cam lift mechanism **93** includes cam **96** with a substantially curved cam surface **95** and a substantially flat top surface **97**, rotating shaft **98**, and shaft supports **99**. Cam **96** is attached to rotating shaft **98**, and shaft **98** is supported by and rotates within shaft supports **99**. In an implant **10G** (FIG. **40**) using this mechanism, the shaft supports **99** are anchored to the inside of housing **11** and rotation of shaft **98** (depicted by curved arrows) rotates the curved cam surface **95** against the bottom of top end plate **13** and moves top end plate **13** away from housing **11** as shown in FIGS. **38A-38B**, **39A-39B** and **40**. The shape of cam **96** determines both the amount of lift that is possible and the relative amount of lift to the amount of rotation of the cam. The cam is not limited by 90 degrees of rotation depicted in the figures. Any shape of a cam that is rotated by any amount from as little as 10 degrees to as much as 355 degrees is possible without departing from the scope of the present invention. Shaft rotation can be accomplished by several means as will be discussed in more detail below. Use of cam lift mechanism **93** as the lifting mechanism along with lower and upper locking supports **20** and **17** for implant **10G** allows the lift mechanism to support only the initial lifting loads and not have to support the repetitive long-term supporting loads on implant **10G** which are borne by the locking supports. Cam **96** does not require a substantially flat top surface **97** as shown in the exemplary embodiment to support top end plate **13**, but such a surface provides a rotational endpoint for the surgeon rotating shaft **98**.

Another alternative embodiment is implant **10H** shown in FIGS. **41**, **43A** and **43B**. Implant **10H** uses a rotating screw lift mechanism **193** as shown in FIG. **42**. This mechanism includes shaft **98**, shaft supports **99**, worm gears **170** attached to shaft **98** and a shaft input end **178** at one end of shaft **98**. The mechanism also includes lift screws **172**, which have lower lift threads **174** and transfer gear **176** and supporting boss

20

186. Applying a torque via shaft input end **178** turns shaft **98**, which turns the attached worm gears **170**. Worm gears **170** turn transfer gear **176** on lift screw **172**. Lift screw **172** is contained within housing **11** by way of its supporting boss **186**, which is seated in housing bearing **188**. Rotation of lift screw **172** transfers force from lower lift threads **174** to upper lift threads **182** on upper lift nut **180**. Upper lift nut **180** is attached to top end plate **13** so that rotation of shaft input end **178** lifts upper end plate **13** away from housing **11**. The relative pitch of worm gears **170** and matching transfer gears **176** and the lower lift threads **174** and matching upper lift threads **182** can be varied to achieve the desired amount of lift relative to the amount of rotation and torque. The torque can be applied by any means well known by those skilled in the art including but not limited to electric motor, pneumatic or hydraulic turbine, or manual rotation of an actuator. Shaft input end **178** is shown as a hexagonal post, but any alternative input end can be used without departing from the scope of the present invention, such as, but not limited to, a square or star-shaped post, a square, star or hexagonal-shaped socket, or a keyed shaft.

As shown in FIG. **44**, an alternative embodiment of the implant **10I** includes a linking element **202** that connects the lower lock supports **20A** and **20B**. The linking element **202** coordinates the action of the lower lock supports **20A** and **20B**. When the locking actuator **26** actuates the leading lower lock support **20A**, the linking element **202** in turn actuates the following lower lock support **20B**. In this embodiment the implant **10I** may require only a single locking actuator **26**, however plural locking actuators as described above (see, for example, FIG. **3**) may be employed for greater actuation force as needed. In addition to actuating the following lower lock support **20B**, the linking element **202** prevents the leading lower lock support **20A** from actuating until the alignment faces **46** of both the leading upper lock supports **17A** and the following upper lock supports **17B** each clear the alignment faces **47** of both the leading lower lock support **20A** and the following lock support **20B**. In this manner the linking element **202** ensures the coordinated actuation of the lower lock supports **20A** and **20B** to ensure that the implant **10I** will always lock at the same height on both sides. This can be advantageous for certain implants placed in the spine where an even expansion of the implant is desired.

Linking plural lower lock supports, such as supports **20A** and **20B**, with a linking element **202** for even expansion in the manner described may be advantageous over an implant with a similarly sized single lock support **20**, and single cylinder **16** and piston **22** due to the increase in the number of support elements, the broader support base, and the increase in expansion force due to the increased number of cylinder and piston pairs. Increasing the size of a single lock support would still have disadvantages of a larger width that would limit the ability for implantation in minimally invasive surgery. Embodiments of the invention are not limited to just the pair of lower locking supports **20A** and **20B** as shown in, for example, FIG. **33**. Rather, any number of sets of cylinders **16**, pistons **22**, upper lock supports **17**, and lower lock supports **20**, with a locking actuator **26** and the appropriate number of linking elements **202** are possible.

For the embodiment illustrated in FIG. **44**, linking element **202** is configured to fit inside attachment grooves **204** on the lower lock support **20A**, **B**. Alternatively, linking element **202** may be configured to rest on the outside diameter of the lower lock support **20A**, **B**. The linking element **202** can also be configured to run underneath the lower lock supports **20A**, **B** as shown in FIGS. **45A-D**. For implant **10I** in FIG. **44** both of the lower lock supports **20A** and **20B** rotate in the same

21

direction when actuated. Elements of an alternative implant shown in FIGS. 45A-B include lower lock supports 20 that actuate with rotation in opposite directions. The linking element 202 is guided between the lower lock supports 20 through a link channel 210 in housing 11 (FIG. 45B). The linking element 202 is constrained in the link channel 210 by a channel cover 208. The linking element 202 is connected to the lower lock supports 20 by means of link pins 206.

The linking element can be made from any of a variety of implantable materials including: a titanium wire, a titanium cable, a stainless steel wire or cable, a nitinol wire, a braided or mono-filament suture from any manner of suture material such as silk, polyester, polypropylene, ePTFE, or UHWPE. An implantable material that has a tensile strength sufficient to transfer the actuation force from the leading lower lock support 20A to the following lower lock support 20B as well as flexibility sufficient to follow the link channel 210 and/or rotate around the lock supports 20 may be used. Linking element 202 can be attached to the lower lock supports 20 in a number of ways known to those practiced in the art, the selection of which depends on factors such as the linking element material and the lower lock support material. Suitable techniques include laser welding, resistance welding, adhesive bonding, crimping, attaching with clamps, pins, or screws, or being threaded through an opening and securing with a knot.

Turning now to FIGS. 46A, B and C an implant 10J with an additional feature, an unlocking tether 212 is shown. Unlocking tether 212 is attached to the following lower lock support 20B in attachment groove 204. Unlocking tether 212 is attached in the opposite direction as the linking element 202 and can be attached in any of the ways described above for attaching the link element 202. The proximal end 214 of the unlocking tether 212 exits the housing 11 of the implant 10J through the unlock port 216. The proximal end 214 can be actuated by an external force or mechanism (not shown). Actuation of the proximal end 214 of the unlocking tether 212 to translate it away from the implant 10J causes rotation of the following lower lock support 20B, which will tension and translate the linking element 202 which will rotate the leading lower lock support 20A. In this manner the unlocking tether 212 can be used to unlock the implant 10J so that it can collapse to a lower or to its original height. In FIG. 46B the implant 10J is collapsed and the unlocking tether 212 is extended a maximum distance out of the unlock port 216. FIG. 46C shows the same implant 10J with the top plate 13 fully expanded above the housing 11 and locked. The unlocking tether 212 has shortened as it was drawn into the implant 10J as the lower lock supports 20 rotated into locking position. Tensioning or pulling on the unlocking tether 212 will unlock the lower lock supports 20 and allow the top plate 13 to collapse back into the housing 11. The ability to unlock and collapse the implant 10J can be highly advantageous to a physician placing the device if there is a need to reposition or replace the device after it has been expanded in-vivo.

Turning now to FIG. 47, another embodiment of an implant 10K is shown with lower lock supports 20 that are located inside the cylinders 16 of the housing 11. In this embodiment the linking element 202 is a solid bar that can transfer compressive as well as tensile loads. The locking actuator 26 rotates the leading lower lock support 20A, which pushes on the linking element 202. The linking element 202 in turn pushes and rotates the following lower lock support 20B. The lower lock supports 20A and 20B engage the upper lock supports 17 that are located inside the pistons 22 (shown in FIG. 14C). The rotation of the following lower lock support 20B pulls the unlocking tether 212 into the housing 11

22

through the unlocking port 38. The unlocking tether 212 can be tensioned away from the housing 11 to reverse the process and unlock the implant 10K.

The use of tension and compression elements as described above are not the only means for coordinating the controlled locking and unlocking of the device. In FIG. 48 an alternative embodiment of the implant 10L is shown wherein thread gears 226A and 226B are used to both lock and unlock the lower lock supports 20 thus forming a combined linking and unlocking element. Threaded gears 226A and 226B are mounted on a shaft 224 that is contained in the base of the housing. The proximal end of shaft 224 has a keyed head 228 that can protrude from or rest in the locking port 222. An external tool (not shown) can interface with the keyed head 228 to rotate it in either direction. Rotating the keyed head 228 will in turn rotate the shaft 224 and the threaded gears 226A and 226B. The threaded gears 226A and 226B transfer the force to the lower lock supports 20 through the geared bottom face 220. In the embodiment shown in FIG. 48 the threaded gear 226A is oriented opposite of the threaded gear 226B. This allows rotation of the shaft 224 to rotate the lower lock supports 20 in opposite directions relative to each other. It is obvious to those schooled in the art that the threaded gears 226A and 226B can be oriented in the same direction if it is desired to rotate the lower lock supports 20 in the same direction. In either case the shaft 224 can be rotated in one direction to rotate the lower lock supports 20 in the locking direction, and the shaft 224 can be rotated in the opposite direction to rotate the lower lock supports 20 in the unlocking direction.

An unlocking tether as described herein can be engaged and tensioned by any number of means including but not limited to gripping the unlocking tether between articulating grips, a collet or split ring clamp, crimping the unlocking tether to a tensioning wire or rod and cutting the unlocking tether to disengage after use, mounting a magnet on the proximal end 214 (FIG. 46A) of the unlocking tether and engaging the magnet with a mating magnet attached to a tensioning wire of rod, adding a female or male thread to the proximal end 214 or the unlocking tether and engaging it with a mating thread on the end of a tensioning rod or wire, or providing a continuous unlocking tether all the way to the point external to the body for tensioning and then cutting the unlocking tether near the implant after use to disengage. It is obvious to those schooled in the art that the unlocking tether can alternatively be pushed or compressed rather than tensioned as long as it is configured to rotate the lower lock supports 20A and B in the unlock direction and deliver sufficient load without buckling when pushed.

FIG. 49 illustrates an alternative embodiment of an implant 10M with a pushable unlocking tether 212a. In this embodiment, unlocking tether 212a engages the proximal lower lock support 20B to rotate it in the unlock direction when the unlocking tether 212a is advanced towards the proximal lower lock support 20B. The link 202 transfers that rotation from the following lower lock support 20B to the leading lower lock support 20A. The link 202 contains engagement pins 230, which extend into receiving slots 232 on the lower lock supports 20A and 20B in order to transfer the lateral movement of the link 202 into rotation of the lower lock supports 20A and 20B. In much the same way, the unlocking tether 212 can contain an engaging pin (not shown) to extend into a receiving slot (not shown) on the following lower lock support 20B to transfer the lateral compressive force applied to the unlocking tether 212a into rotation of the lower lock supports 20B. This is just one method for attaching or engaging the unlocking tether 212 to the lower lock support 20 the

numerous methods previously described herein for attaching or engaging the link 202 to the lower lock supports 20 can be used for attaching or engaging the tether 212 as well.

One advantage to pushing the unlocking tether 212a to unlock the implant 10M is that the method for engaging the unlocking tether is simplified. Unlocking tether 212a, which is pushed to unlock the implant 10M can be contained within the implant 10M and a push rod (not shown) can be easily directed into the implant 10M through the unlock port 216 to actuate the unlocking tether 212a and unlock the implant 10M such that it can collapse. This eliminates the need to attach to the unlocking tether 212a which is required when the unlocking tether 212a is tensioned to unlock the implant 10M.

FIGS. 50A-D illustrate an alternate embodiment of the implant 10N embodying features of the invention. Similar to the implant 110 as shown in FIGS. 13A and 13B, the top end plate 113 of the implant 10N articulates relative to the distal piston 122A and proximal piston 122B. The ends of the articulating top plate 113 have spherical projections 2001A and 20001B which are contained within mating pockets 2002A and 2002B in the two pistons 122A and 122b. Split rings 2006A and 2006B are placed over the spherical projections 2001A and 20001B and into the pistons 122A and 122B to vertically constrain the articulating top plate 113 to the pistons. This geometry provides articulation of the top plate 113 along not only the long axis (the axis extending along the line 50C in FIG. 50C), as with the implant 110 shown in FIGS. 13A-B, but also provides articulation in a side-to-side direction, which is an advantage for providing congruence of the implant to the intervertebral space. Thus, the articulating top plate 113 is polyaxially movably coupled to the pistons 122A and 122B, allowing the plate 113 to articulate about at least two axes.

Also shown in FIG. 50D are vertical constraints 2003A and 2003B which are attached to the distal piston 122A and proximal piston 122B. These two constraints 2003A and 2003B fit inside channels 2004A and 2004B in the housing 111. The top portion of the channels 2004A and 2004B have a narrowed portion 2005A and 2005B that prevent the vertical constraints 2003A and 2003B from advancing out of the housing 111. In this manner these vertical constraints 2003A and 2003B limit the maximum vertical movement of the pistons 122A and 122B relative to the housing 111.

FIGS. 51A-B illustrate another alternative embodiment. FIGS. 51A-B illustrate an implant 10P that can have features similar to features in the embodiments illustrated in FIGS. 13A, 14A-C, and 49. The implant 10P has the articulating top plate 113 similar to that shown in FIG. 13A which pivots relative to the distal piston 122A and proximal piston 122B about a distal pivot pin 2101A and a proximal pivot pin 2101B. The implant 10P has a distal piston 122A and a proximal piston 122B. As with the pistons 222a and 222b shown in FIGS. 14A-C, the pistons 122A and 122B can have internal upper lock supports 217. Unlike implant 210, in the illustrated embodiment, the pistons 122A and 122B do not rotate relative to the housing 111 as is the case in the implant 210. Instead, lower lock supports 20A and 20B similar to those shown in FIG. 49 rotate relative to the housing 111 and the two pistons 122A and 122B to lock the height of the expanded implant. In this manner, benefits of several of the previously described embodiments are combined to provide and implant 10P that can lock at different distal and proximal heights.

FIGS. 52A-F illustrate an alternative embodiment of the present invention, exemplified by implant 10R. In this embodiment, implant 10R can include a distal piston top plate

2222 that can be completely separate from a proximal piston top plate 2223. As shown in FIGS. 52B-D, the two piston top plates 2222 and 2223 can each expand to different heights relative to the housing 111. Thus, the independently adjustable top plates and their respective pistons provide a simple construct that can achieve variable expansion similar to the articulating top plate 113 in implants 10N and 10P.

In some embodiments, the extendable members, such as pistons 122A and 122B, may be actuated by a common actuator such as a single syringe or other pressurized fluid source, but constrained as described herein to rise to independent/different heights. Such constraint may be provided by specific constraint means as described, by a common top plate such as shown in FIG. 50D or a combination thereof.

As shown in FIG. 52F, the implant 10R can include a proximal lower lock support 20B that can have stepped support surfaces that have shorter increments than the stepped support surfaces on a distal lower lock support 20A. The mating stepped support surfaces on the proximal upper lock support (not shown) in the proximal piston 122B can also have shorter increments than the stepped support surfaces on the upper lock support in the distal piston 122A. This variation in stepped support surface can be designed to produce a specifically desired expanded height difference between the expanded distal piston top plate 2222 and the expanded proximal piston top plate 2223. In addition, the expanded height difference can vary with the amount of expansion. This variation can be valuable, for example, for creating lordotic congruence between the implant 10R and the vertebral bodies as the amount of lordosis required for proper congruence and spinal foraminal opening can increase along with the increase in distance between the vertebral bodies.

The implant 10R can also have vertical constraints 2005A and 2005B which can be attached to the housing 111. In the illustrated embodiment, the vertical constraints 2005A and 2005B can prevent wide portions 2003A and 2003B of the distal piston 122A and proximal piston 122B from advancing out of the housing 111. In this manner, these vertical constraints 2005A and 2005B can limit the maximum vertical movement of the pistons 2222 and 2223 relative to the housing 111.

FIG. 53 illustrates yet another alternative embodiment. As shown in FIG. 53, an implant 10S can have a distal piston 122A that can have both a horizontal vertebral engagement surface 2240 and an angled vertebral engagement surface 2242, such that the distal piston 122A can have a variation in vertebral engagement surface angles. These variations in vertebral engagement surface angles can be beneficial for providing even better congruence between the implant 10S and the vertebral bodies when a lordotic or variable height expansion is desired. The implant 10S can also have a proximal piston 122B with a higher horizontal vertebral engagement surface 2244 and a lower horizontal vertebral engagement surface 2246, which can also improve congruence between the implant 10S and the vertebral bodies when a lordotic or variable height expansion is desired. As will be recognized by a person of ordinary skill in the art, any combination of these varied vertebral engagement surfaces can be employed on either the distal piston 122A, the proximal piston 122B, the articulating top plate 113 or the posterior surface of the housing 111 to provide optimal vertebral body congruency.

The features of the current invention have been described in terms of an implant comprised of a pair of cylinder/piston/lock/and related features, however it is obvious to those schooled in the art that the described features can be included in an implant with only a single set or more than two sets of these features.

A lateral cage implant, as illustrated for exemplary embodiments of the present invention herein, is particularly advantaged by the use of anchors as described herein because the lateral approach to the spine is a long and narrow approach, which limits the ability of the surgeon to use other instrumentation to extend anchors from the cage (as can be done more readily, for example, with an anterior approach where the access is not as narrow). However, as will be appreciated by persons of ordinary skill in the art, while particular, additional advantages may be presented in connection with the lateral approach and cages designed therefore, anchors according to embodiments of the present invention are advantageous for any approach as they can produce the required extension forces regardless of patient anatomy or other restrictions on the use of alternative extension means by the surgeon.

Elements of the description herein focused on the manner in which the locking elements are configured to lock the implant in extended configurations. Although this locking action resists the forces placed on the implant that would tend to force it back into a collapsed configuration, that is not the only force the locking elements address. Once inserted between vertebral bodies the implant is subject to lateral forces and torsion moments as well as compressive forces. The locking features along with the other elements of the invention are designed to resist all of these forces to provide an implant that provides stable fixation and distraction.

A partial or complete discectomy is usually performed prior to the insertion of the spinal implant having features of the invention between vertebral bodies. The implant is introduced in its unexpanded state to enable it to be inserted posteriorly with minimal trauma to the patient and risk of injury to nerve roots. Once in place the implant can be expanded to provide both medial and lateral spinal correction. The implant has an unexpanded height of about 5 to about 15 mm, typically about 7 mm and is expandable to at least 130% to about 180% of the unexpanded height. Typically the implant is about 9 to about 15 mm wide, typically about 12 mm wide and about 25 to about 55 mm long, typically about 35 mm long to facilitate minimally invasive insertion and thereby minimize trauma to the patient and risk of injury to nerve roots.

Additional details of the implant such as the attachment of hydraulic lines and lines for transmission of a slurry or liquid bone graft material, device and hydraulic fluid delivery accessories and the like can be found in co-pending application Ser. No. 11/535,432 filed on Sep. 26, 2006 and Ser. No. 11,692,800, filed on Mar. 28, 2007, which are incorporated herein by reference.

It will be appreciated that the implant, including its various components should be formed of biocompatible, substantially incompressible material such as PEEK or titanium, and preferably type 6-4 titanium alloy or other suitable materials which will allow for long-term deployment within a patient.

While the invention has been described in connection with what are presently considered to be the most practical and certain preferred embodiments, it is to be understood that the invention is not limited to the disclosed embodiments and alternatives as set forth above, but on the contrary is intended to cover various modifications and equivalent arrangements included within the scope of the following claims.

For example, while implants described herein are expanded by hydraulic fluid, other expansion means may be employed. For example, the screw mechanism described herein may be employed to expand scissor jacks within the implant to engagement adjacent vertebral surfaces. Further, the implant can be provided with load or pressure sensors that register differential pressure and pressure intensity exerted on the engaging surfaces of the SEC by the patient's vertebrae end plates to generate corrective signals, for example by

computer control, that are used, e.g. by the surgeon or by a computer-controlled mechanism to realign the patient's spine. The invention may further include a system that makes these adjustments, responsive to sensor signals, in real time and on a continual basis, such that the shapes of the implant changes to realign the patient's spine or mechanism. Preferably, such system is contemplated for use in setting the positions of the pistons during installation of the implant.

While particular forms of the invention have been illustrated and described herein, it will be apparent that various modifications and improvements can be made to the invention. Additional details of the spinal implant devices may be found in the patents and applications referenced herein. To the extent not otherwise disclosed herein, materials and structure may be of conventional design.

Moreover, individual features of embodiments of the invention may be shown in some drawings and not in others, but those skilled in the art will recognize that individual features of one embodiment of the invention can be combined with any or all the features of another embodiment. Accordingly, it is not intended that the invention be limited to the specific embodiments illustrated. It is therefore intended that this invention be defined by the scope of the appended claims as broadly as the prior art will permit.

Terms such as "element", "member", "component", "device", "means", "portion", "section", "steps" and words of similar import when used herein shall not be construed as invoking the provisions of 35 U.S.C. §112(6) unless the following claims expressly use the terms "means for" or "step for" followed by a particular function without reference to a specific structure or a specific action. All patents and all patent applications referred to above are hereby incorporated by reference in their entirety.

What is claimed is:

1. A spinal implant for placement between first and second vertebral bodies, comprising:

at least two separate first members having a surface for engaging a first vertebral body and a side surface;

a second member cooperating with the at least two first members and having a surface for engaging a second vertebral body;

a housing; and

at least two independently extendable support elements at least partially within the housing, each having a contracted configuration to facilitate deployment of the implant between the first and second vertebral bodies and at least one extended configuration to extend said at least two first members away from the second member so that the surface thereof engages the first vertebral body,

wherein the at least two first members comprises separate members with one of the separate members connected to each of the at least two independently extendable support elements, and

wherein the at least two first members accommodates different extended heights of the at least two extendable support elements with respect to each other;

wherein the at least two independently extendable support elements comprise fluid actuatable pistons actuatable by a common actuator to different heights above the second member and

wherein the side surfaces of the at least two first members are adjacent to each other when the at least two independently extendable support elements are in the contracted configuration.

2. The spinal implant of claim 1, wherein the at least two independently extendable support members comprise fluid actuatable pistons and the common actuator comprises a single source of fluid pressure.

27

3. The spinal implant of claim 1, wherein means permitting said at least one first member to accommodate different extended heights comprises an articulating plate movably coupled to each said extendable support elements.

4. The spinal implant of claim 3, wherein the articulating plate is polyaxially coupled to said extendable support elements.

5. The spinal implant of claim 3, wherein the articulating plate is coupled to said extendable support elements by spherical projections.

6. The spinal implant of claim 1, further comprising a locking system which has a locking element that mechanically engages or interlocks with the extendable support element of the first member to lock the implant between the first and second vertebral bodies in an expanded configuration.

7. The spinal implant of claim 1, wherein the separate members of the at least one first member comprise a proximal first member coupled to a proximal extendable support element and a distal first member coupled to a distal extendable support element.

8. The spinal implant of claim 7, wherein the surface for engaging the first vertebral body on at least one of the proximal and distal first members comprises a plurality of surface, wherein at least one of the plurality of surfaces is in a plane that is non-parallel with respect to a plane of another one of the plurality of surfaces, such that at least one of the proximal and distal first members has a plurality of vertebral engagement surface angles.

9. The spinal implant of claim 1, wherein at least one of the at least two independently extendable support elements further comprise a vertical constraint.

10. The spinal implant for placement between first and second vertebral bodies, comprising:

at least two separate first members each having a top surface for engaging a first vertebral body, a side surface, and a bottom surface;

a second member cooperating with the at least two first members and having a surface for engaging a second vertebral body;

a housing; and

at least two independently extendable support elements, each having a contracted configuration to facilitate deployment of the implant between the first and second vertebral bodies and at least one extended configuration

28

to extend the at least two first members away from the second member so that the surface thereof engages the first vertebral body while accommodating different extended heights of said at least two extendable support members with respect to each other,

wherein the at least two independently extendable support elements comprise fluid actuatable pistons; and

wherein the bottom surfaces of the at least two first members abut the housing and the side surfaces of the at least two first members are adjacent to each other when the at least two independently extendable support elements are in the contracted configuration.

11. The spinal implant of claim 10, wherein the at least two independently extendable support members are actuatable by a common actuator to different heights above the second member.

12. The spinal implant of claim 11, wherein the common actuator comprises a single source of fluid pressure.

13. The spinal implant of claim 10, further comprising a locking system which has a locking element that mechanically engages or interlocks with the extendable support element of the first member to lock the implant between the first and second vertebral bodies in an expanded configuration.

14. The spinal implant of claim 13, wherein the locking system comprises a plurality of inter-engaging locking elements.

15. The spinal implant of claim 14, wherein one of the inter-engaging locking elements is an upper lock support member and another of the inter-engaging locking elements is a lower lock support member.

16. The spinal implant of claim 15, wherein the upper lock support member has a multi-stepped support surface and the lower lock support member has a multi-stepped support surface configured to engage the multi-stepped support surface of the upper lock support member.

17. The spinal implant of claim 16, including a locking actuator that is configured to effect relative motion between the upper and lower lock support members when the at least one extendable member is extended so as to lock the implant in an extended configuration by engaging the multi-stepped support surfaces of the upper lock support members and the lower lock support members.

* * * * *

UNITED STATES PATENT AND TRADEMARK OFFICE
CERTIFICATE OF CORRECTION

PATENT NO. : 8,992,620 B2
APPLICATION NO. : 13/843390
DATED : March 31, 2015
INVENTOR(S) : Ashley et al.

Page 1 of 1

It is certified that error appears in the above-identified patent and that said Letters Patent is hereby corrected as shown below:

In the Claims

Column 28, line 1, delete "form" and insert therefor --from--.

Signed and Sealed this
Second Day of February, 2016

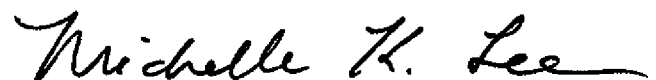

Michelle K. Lee
Director of the United States Patent and Trademark Office